

SERVICE & OPERATING MANUAL

SandPIPER II®

Model S15 Non-Metallic Design Level 2

Table of Contents

Engineering Data and Temperature Limitations	1
Explanation of Pump Nomenclature	2
Performance Curve, Model S15 Non-Metallic Design Level 2	3
Dimensions: S15 Non-Metallic	4
Metric Dimensions: S15 Non-Metallic	5
Dimensions: S15 Non-Metallic with RuppGUARD™ Spill Prevention	6
Metric Dimensions: S15 Non-Metallic with RuppGUARD™ Spill Prevention	7
Principle of Pump Operation	8
Installation and Start-up	8
Air Supply	8
Air Valve Lubrication	8
Air Line Moisture	8
Air Inlet and Priming	8
Between Uses	8
Installation Guide	9
Important Safety Information	10
Material Codes	10
Troubleshooting	11
Warranty	11
Composite Repair Parts Drawing	12
Overlay Option Drawing	12
Composite Repair Parts List	13
RuppGUARD™ Spill Prevention Option for Virgin PTFE Equipped Pumps	14
RuppGUARD™ Spill Prevention Repair Parts List	14
RuppGUARD™ Spill Prevention Concept	15
RuppGUARD™ Spill Prevention Option Diaphragm Servicing	15
Filling RuppGUARD™ Chambers with Liquid	15
RuppGUARD™ Spill Prevention Option for TPE Equipped Pumps	16
RuppGUARD™ Spill Prevention Repair Parts List	16
RuppGUARD™ Spill Prevention Concept with TPE Diaphragms	17
RuppGUARD™ Spill Prevention Option with TPE Diaphragm	17
Air Distribution Valve Assembly Drawing	18



U.S. Patent #
400,210;
5,996,627;
6,241,487

Main Air Valve Assembly Parts List	18
Air Distribution Valve Servicing	19
Air Distribution Valve with Stroke Indicator Options	20
Air Distribution Valve with Stroke Indicator Parts List	20
Air Distribution Valve with Stroke Indicator Servicing	21
Solenoid Shifted Air Valve Drawing	22
Solenoid Shifted Air Valve Parts List	22
Solenoid Shifted Air Distribution Valve Option	23
Pilot Valve Assembly Drawing	24
Pilot Valve Assembly Parts List	24
Pilot Valve Servicing	25
Diaphragm Service Drawing, Non-Overlay	26
Diaphragm Service Drawing, with Overlay	26
Diaphragm Servicing	27
Overlay Diaphragm Service	27
Pumping Hazardous Liquids	28
Converting the pump for piping the exhaust air	28
Exhaust Conversion Drawing	28
Converted Exhaust Illustration	28
Modular Check Valve Servicing	29
Modular Check Valve Drawing	29
Dual Port Option Drawing	30
Dual Porting Options	31
Dual porting of both suction and discharge ends of the pump	31
Single porting of the suction and dual porting of the pump discharge	31
Dual porting of the suction and single porting of the pump discharge	31
RuppTech® Leak Detection Options Drawing	32
RuppTech® Electronic Leak Detector Installation	32
RuppTech® Mechanical Leak Detector Installation	32
RuppTech® Pulse Output Kit Drawing	33
RuppTech® Pulse Output Kit Option	33
Exhaust Port or Auxiliary Muffler Setup	33
Integral Muffler Setup	33

**WARREN
RUPP®**

Quality System
ISO9001 Certified

Environmental
Management System
ISO14001 Certified

IDEX
IDEX CORPORATION

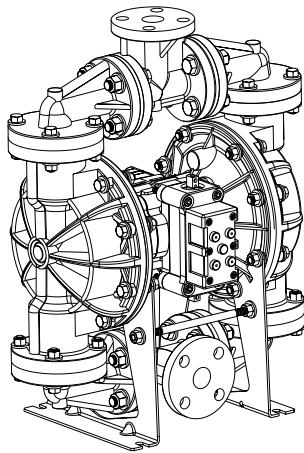

Air Exhaust Side View

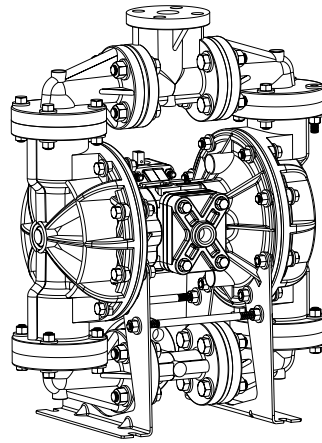

Air Inlet Side View

CE

U.S. Patent #
5,851,109; 5,996,627;
400,210 & 6,241,487
Other U.S. Patents
Applied for

SandPIPER II®

**S15 Non-Metallic
Design Level 2
Ball Valve**

**Air-Powered
Double-Diaphragm Pump**

ENGINEERING, PERFORMANCE
& CONSTRUCTION DATA

INTAKE/DISCHARGE PIPE SIZE 1½" ANSI Flange or PN10 40mm DIN Flange	CAPACITY 0 to 90 US gallons per minute (0 to 340 liters per minute)	AIR VALVE No-lube, no-stall design	SOLIDS-HANDLING Up to .47 in. (12mm)	HEADS UP TO 100 psi or 231 ft. of water (7 bar or 70 meters)	DISPLACEMENT/STROKE .36 US gallon / 1.36 liter
---	--	---	--	---	--

⚠ CAUTION! Operating temperature limitations are as follows:

Materials	Operating Temperatures		
	Maximum*	Minimum*	Optimum**
Santoprene® Injection molded thermoplastic elastomer with no fabric layer. Long mechanical flex life. Excellent abrasion resistance.	212°F 100°C	-10°F -23°C	50° to 212°F 10°C to 100°C
PTFE Chemically inert, virtually impervious. Very few chemicals are known to react chemically with PTFE: molten alkali metals, turbulent liquid or gaseous fluorine and a few fluoro-chemicals such as chlorine trifluoride or oxygen difluoride which readily liberate free fluorine at elevated temperatures.	212°F 100°C	-35°F -37°C	50°F to 212°F 10°C to 100°C
PVDF	200°F -93°C	-10°F -13°C	
Polypropylene	150°F 65°C	-40°F 5°C	
Polyurethane	210°F 99°C	-40°F -40°C	-40°F to 210°F -40°C to 99°C

For specific applications, always consult "Chemical Resistance Chart" Technical Bulletin

*Definite reduction in service life.

**Minimal reduction in service life at ends of range.

SandPIPER II® pumps are designed to be powered only by compressed air.

Explanation of Pump Nomenclature

S15 Non-Metallic - Design Level 2- Ball Valve

MODEL	Pump Brand	Pump Size	Check Valve Type	Design Level	Wetted Material	Diaphragm/ Check Valve Materials	Check Valve Seat	Non-Wetted Material Options	Porting Options	Pump Style	Pump Options	Kit Options	Shipping Weight lbs. (kg)
S15B2P1PQAS000.	S	15	B	2	P	1	P	Q	A	S	0	00.	53 (24)
S15B2K1KQAS000.	S	15	B	2	K	1	K	Q	A	S	0	00.	65 (29)
S15B2P2PQAS000.	S	15	B	2	P	2	P	Q	A	S	0	00.	53 (24)
S15B2K2KQAS000.	S	15	B	2	K	2	K	Q	A	S	0	00.	65 (29)
S15B2P3PQAV000.	S	15	B	2	P	3	P	Q	A	V	0	00.	58 (26)
S15B2K3KQAV000.	S	15	B	2	K	3	K	Q	A	V	0	00.	77 (35)
S15B2P4PQAV000.	S	15	B	2	P	4	P	Q	A	V	0	00.	58 (26)
S15B2K4KQAV000.	S	15	B	2	K	4	K	Q	A	V	0	00.	77 (35)

Pump Brand

S= SandPIPER II®

Pump Size

15=1½"

Check Valve Type

B= Ball

Design Level

2= Design Level 2

Wetted Material

K= PVDF

P= Polypropylene

Diaphragm Check Valve Materials

1= Santoprene/Santoprene

2= PTFE-Santoprene Backup/PTFE

3= PTFE Pumping, PTFE-Santoprene Backup Driver/PTFE

4= Santoprene Pumping, Santoprene Driver/Santoprene

Check Valve Seat

K= PVDF

N= Nylon

P= Polypropylene

Non-Wetted Material Options

A= Painted Aluminum

J= Painted Aluminum PTFE

Q= Epoxy Coated Aluminum

K= PTFE Coated Aluminum

L= PTFE Coated Aluminum with PTFE Coated Hardware

R= Epoxy Coated Aluminum with PTFE Coated Hardware

Porting Options

A= ANSI Flange

D= DIN Flange

7= Dual Porting (ANSI)

8= Top Dual Porting (ANSI)

9= Bottom Dual Porting (ANSI)

Pump Style

D=RuppGUARD™ with Electronic Leak Detection (110V)

E=RuppGUARD™ with Electronic Leak Detection 220V)

M=RuppGUARD™ with Mechanical Leak Detection

S= Standard

V=RuppGUARD™ with Visual Leak Detection

Pump Options

0= None

1= 3M Muffler

2= Mesh Muffler

3= High temperature Air Valve w/Encapsulated Muffler

4= High temperature Air Valve w/3M Muffler

5= High temperature Air Valve w/Mesh Muffler

Kit Options

00.=None

P0.=0-30VDC Pulse Output Kit

P1.=Intrinsically-Safe 10-30VDC Pulse Output Kit

P2.=110/120 or 220/240VAC

Pulse Output Kit

P3.=Intrinsically-Safe 110/120VAC

Pulse Output Kit

P4.=Intrinsically-Safe 220/240VAC

Pulse Output Kit

E0.=Solenoid Kit with 24VDC Coil

E1.=Solenoid Kit with 24VDC Explosion-Proof Coil

E2.=Solenoid Kit with 24VAC/12VDC Coil

E3.=Solenoid Kit with 24VAC/12VDC

Explosion-Proof Coil

E4.=Solenoid Kit with 110VAC Coil

E5.=Solenoid Kit with 110VAC Explosion-Proof Coil

E6.=Solenoid Kit with 220VAC Coil

E7.=Solenoid Kit with 220VAC Explosion-Proof Coil

SP.=Stroke Indicator Pins

Performance Curve, Model S15 Non-Metallic Design Level 2

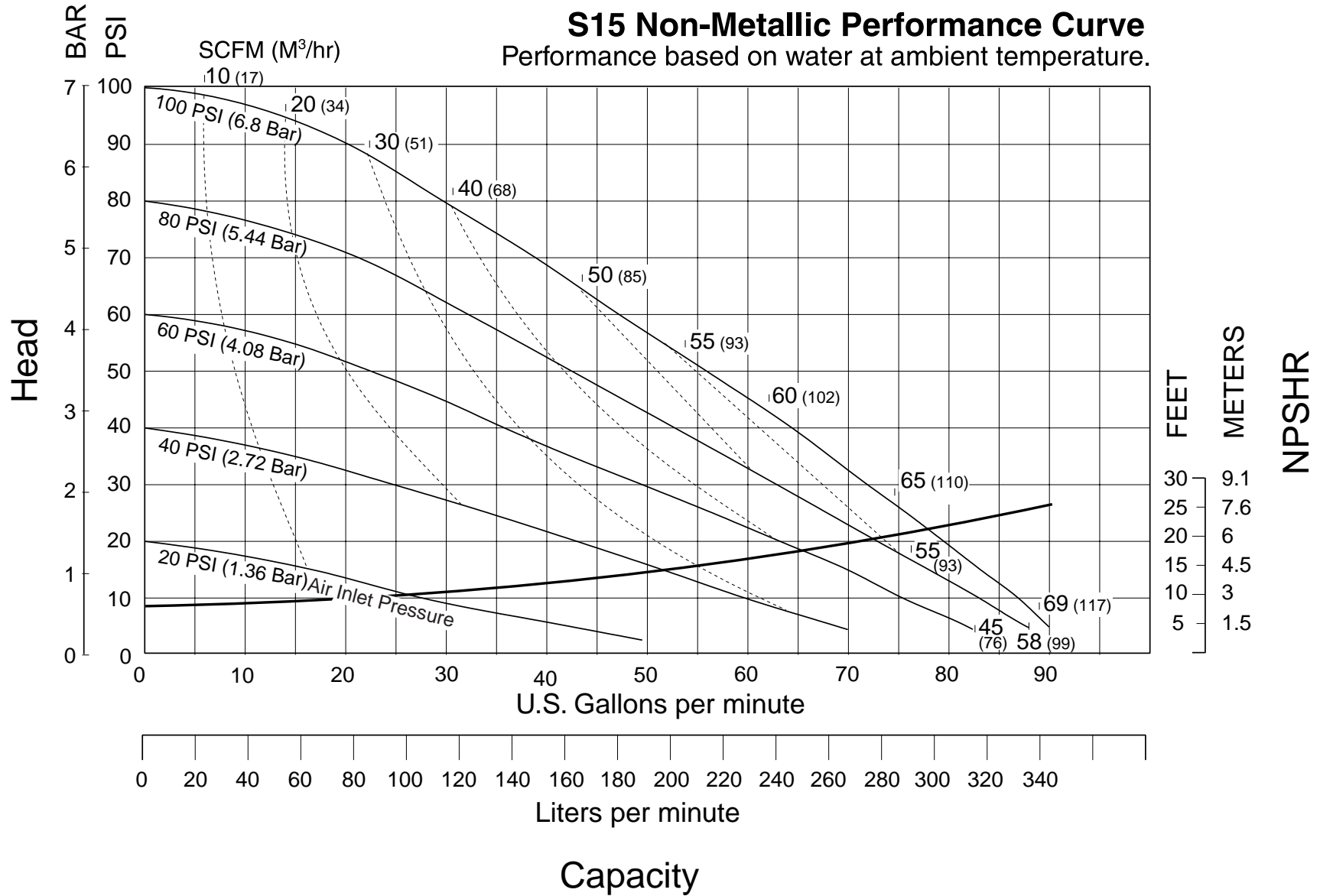

Dimensions: S15 Non-Metallic

Dimensions in Inches

Dimensional tolerance: $\pm 1/8"$

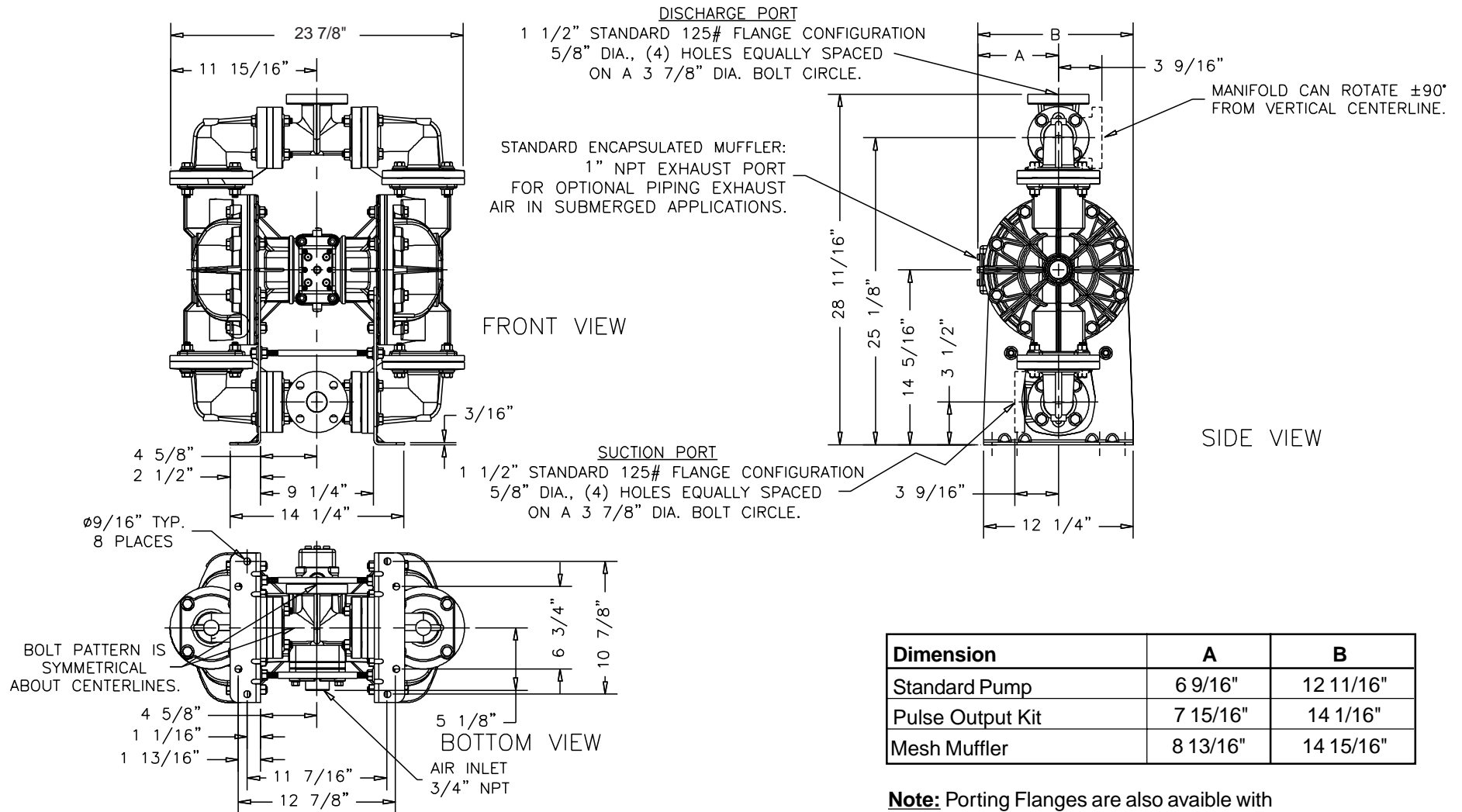

Note: Porting Flanges are also available with PN10 40mm DIN bolting configuration.

Metric Dimensions: S15 Non-Metallic

Dimensions in Millimeters
Dimensional tolerance: $\pm 3\text{mm}$

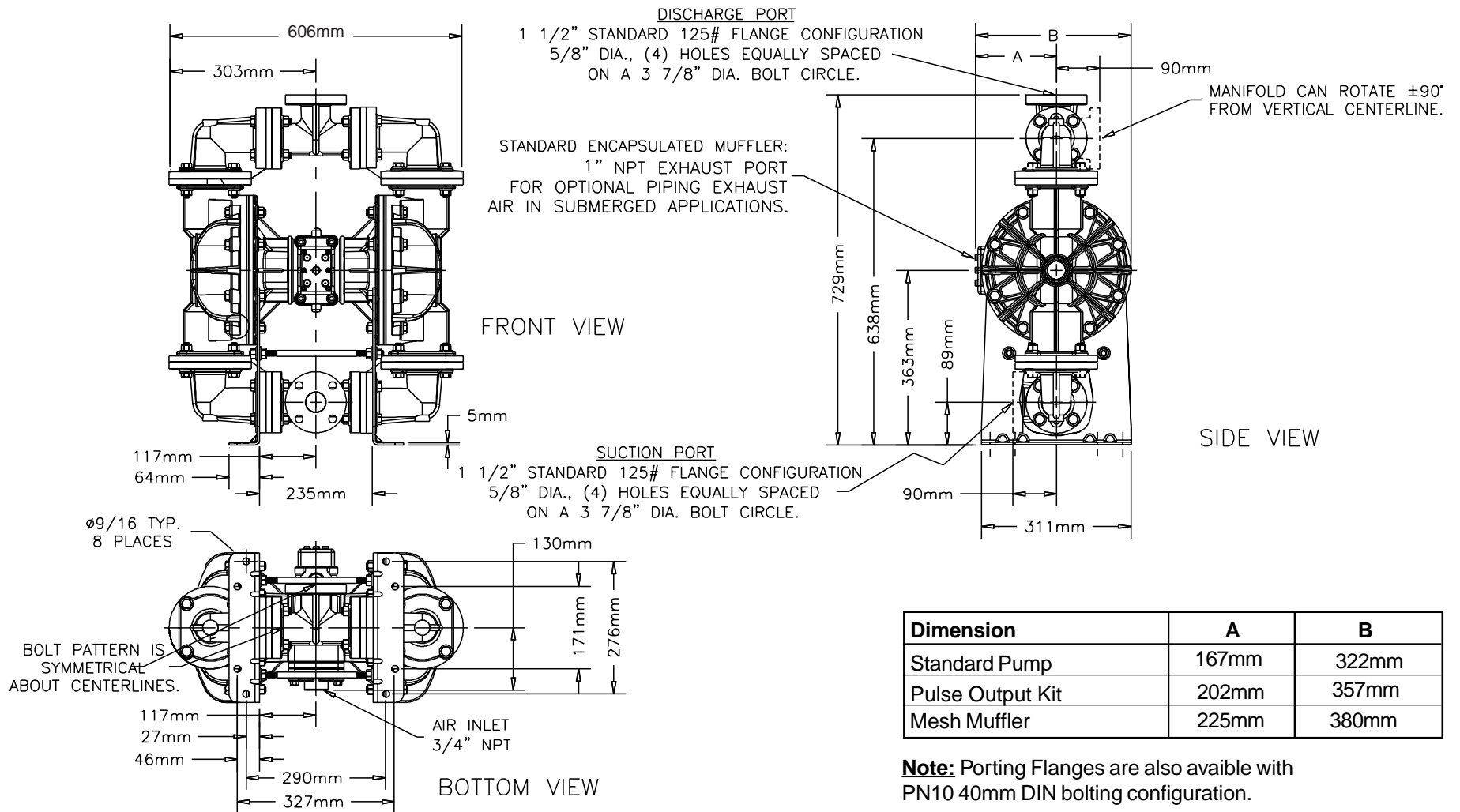

Dimension	A	B
Standard Pump	167mm	322mm
Pulse Output Kit	202mm	357mm
Mesh Muffler	225mm	380mm

Note: Porting Flanges are also available with PN10 40mm DIN bolting configuration.

Dimensions: S15 Non-Metallic with RuppGUARD™ Spill Prevention

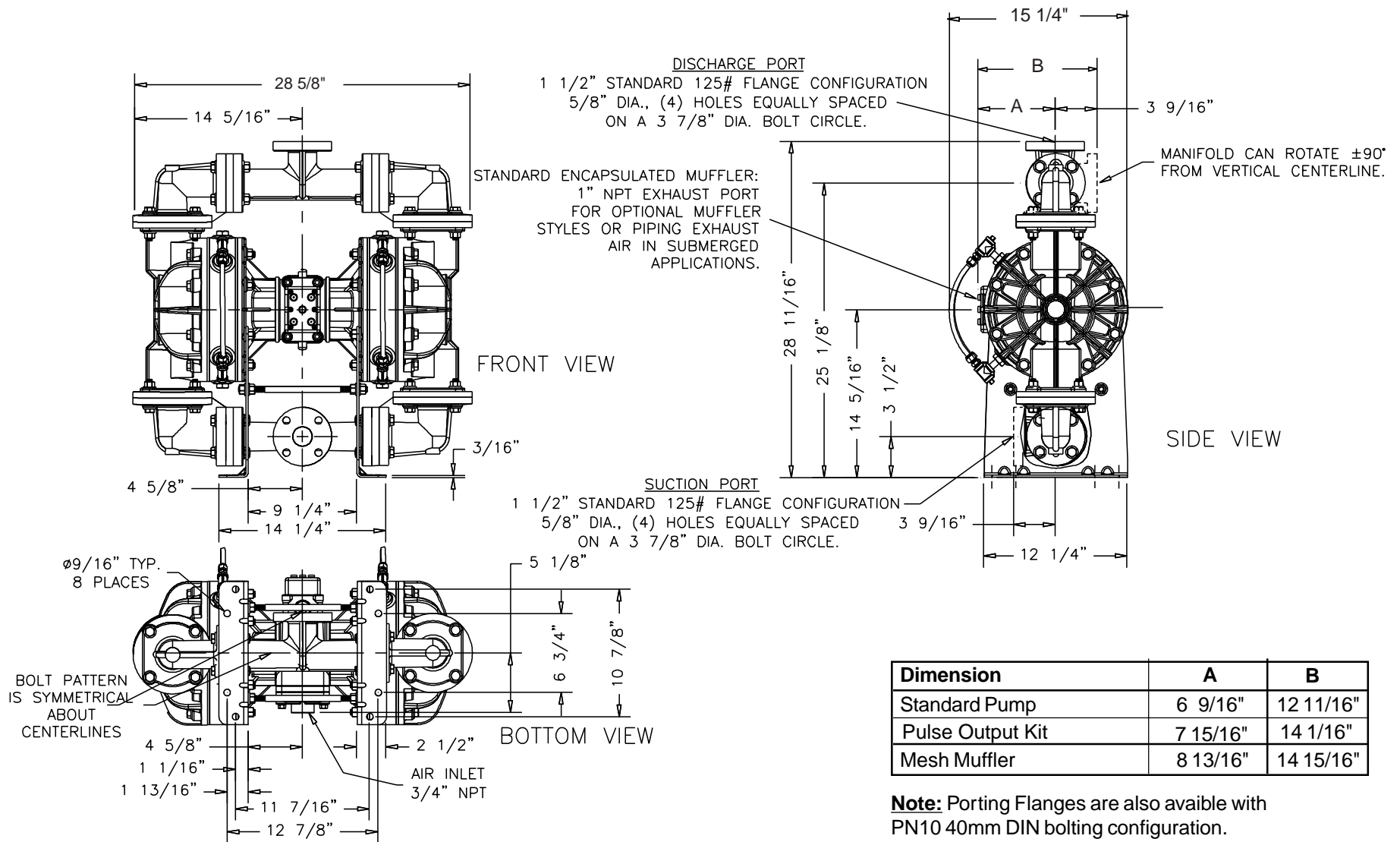

Dimension	A	B
Standard Pump	6 9/16"	12 11/16"
Pulse Output Kit	7 15/16"	14 1/16"
Mesh Muffler	8 13/16"	14 15/16"

Note: Porting Flanges are also available with PN10 40mm DIN bolting configuration.

Metric Dimensions: S15 Non-Metallic with RuppGUARD™ Spill Prevention

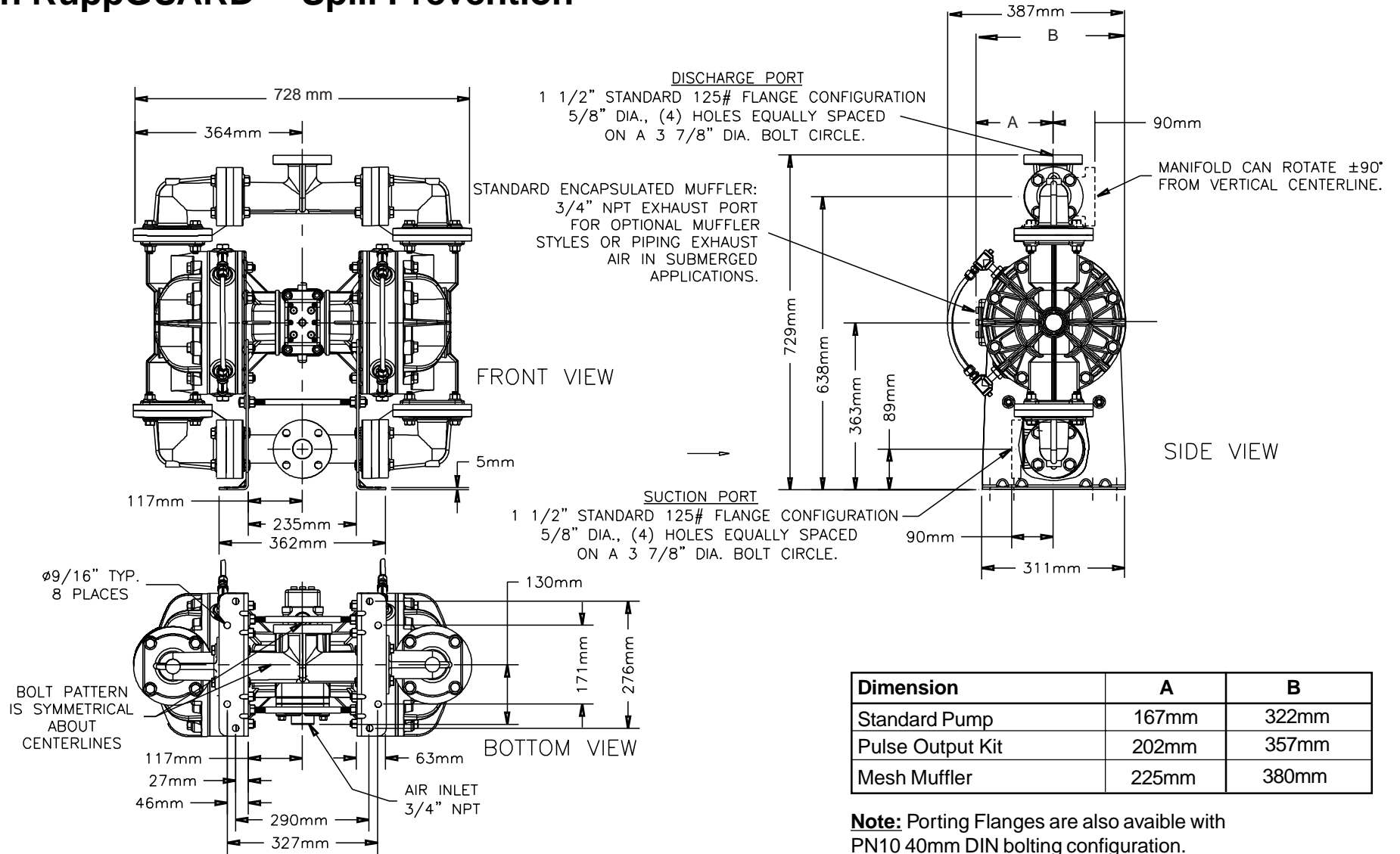

Dimension	A	B
Standard Pump	167mm	322mm
Pulse Output Kit	202mm	357mm
Mesh Muffler	225mm	380mm

Note: Porting Flanges are also available with PN10 40mm DIN bolting configuration.

PRINCIPLE OF PUMP OPERATION

This ball type check valve pump is powered by compressed air and is a 1:1 ratio design. The inner side of one diaphragm chamber is alternately pressurized while simultaneously exhausting the other inner chamber. This causes the diaphragms, which are connected by a common rod secured by plates to the centers of the diaphragms, to move in a reciprocating action. (As one diaphragm performs the discharge stroke the other diaphragm is pulled to perform the suction stroke in the opposite chamber.) Air pressure is applied over the entire inner surface of the diaphragm while liquid is discharged from the opposite side of the diaphragm. The diaphragm operates in a balanced condition during the discharge stroke which allows the pump to be operated at discharge heads over 200 feet (61 meters) of water.

For maximum diaphragm life, keep the pump as close to the liquid being pumped as possible. Positive suction head in excess of 10 feet of liquid (3.048 meters) may require a back pressure regulating device to maximize diaphragm life.

Alternate pressurizing and exhausting of the diaphragm chamber is performed by an externally mounted, pilot operated, four way spool type air distribution valve. When the spool shifts to one end of the valve body, inlet pressure is applied to one diaphragm chamber and the other diaphragm chamber exhausts. When the spool

shifts to the opposite end of the valve body, the pressure to the chambers is reversed. The air distribution valve spool is moved by an internal pilot valve which alternately pressurizes one end of the air distribution valve spool while exhausting the other end. The pilot valve is shifted at each end of the diaphragm stroke when an actuator plunger is contacted by the diaphragm plate. This actuator plunger then pushes the end of the pilot valve spool into position to activate the air distribution valve.

The chambers are connected with manifolds with a suction and discharge check valve for each chamber, maintaining flow in one direction through the pump.

INSTALLATION AND START-UP

Locate the pump as close to the product being pumped as possible. Keep the suction line length and number of fittings to a minimum. Do not reduce the suction line diameter.

For installations of rigid piping, short sections of flexible hose should be installed between the pump and the piping. The flexible hose reduces vibration and strain to the pumping system. A surge suppressor is recommended to further reduce pulsation in flow.

AIR SUPPLY

Air supply pressure cannot exceed 100 psi (7 bar). Connect the pump air inlet to an air supply of sufficient capacity and pressure required for desired performance. When the air supply line

is solid piping, use a short length of flexible hose not less than ½" (13mm) in diameter between the pump and the piping to reduce strain to the piping. The weight of the air supply line, regulators and filters must be supported by some means other than the air inlet cap. Failure to provide support for the piping may result in damage to the pump. A pressure regulating valve should be installed to insure air supply pressure does not exceed recommended limits.

AIR VALVE LUBRICATION

The air distribution valve and the pilot valve are designed to operate WITHOUT lubrication. This is the preferred mode of operation. There may be instances of personal preference or poor quality air supplies when lubrication of the compressed air supply is required. The pump air system will operate with properly lubricated compressed air supply. Proper lubrication requires the use of an air line lubricator (available from Warren Rupp) set to deliver one drop of SAE 10 non-detergent oil for every 20 SCFM (9.4 liters/sec.) of air the pump consumes at the point of operation. Consult the pump's published Performance Curve to determine this.

AIR LINE MOISTURE

Water in the compressed air supply can create problems such as icing or freezing of the exhaust air, causing the pump to cycle erratically or stop operating. Water in the air supply can be reduced by using a point-of-use air dryer to supplement the user's air drying

equipment. This device removes water from the compressed air supply and alleviates the icing or freezing problems.

AIR INLET AND PRIMING

To start the pump, open the air valve approximately ½ to ¾ turn. After the pump primes, the air valve can be opened to increase air flow as desired. If opening the valve increases cycling rate, but does not increase the rate of flow, cavitation has occurred. The valve should be closed slightly to obtain the most efficient air flow to pump flow ratio.

BETWEEN USES

When the pump is used for materials that tend to settle out or solidify when not in motion, the pump should be flushed after each use to prevent damage. (Product remaining in the pump between uses could dry out or settle out. This could cause problems with the diaphragms and check valves at restart.) In freezing temperatures the pump must be completely drained between uses in all cases.

INSTALLATION GUIDE Top Discharge Ball Valve Unit

Available from
Warren Rupp

- ① Surge Suppressor
- ② 020-050-000 Filter/Regulator
- ③ 020-050-001 Lubricator
- ④ 020-047-007 Air Dryer



CAUTION
The air exhaust should be piped to an area for safe disposition of the product being pumped, in the event of a diaphragm failure.

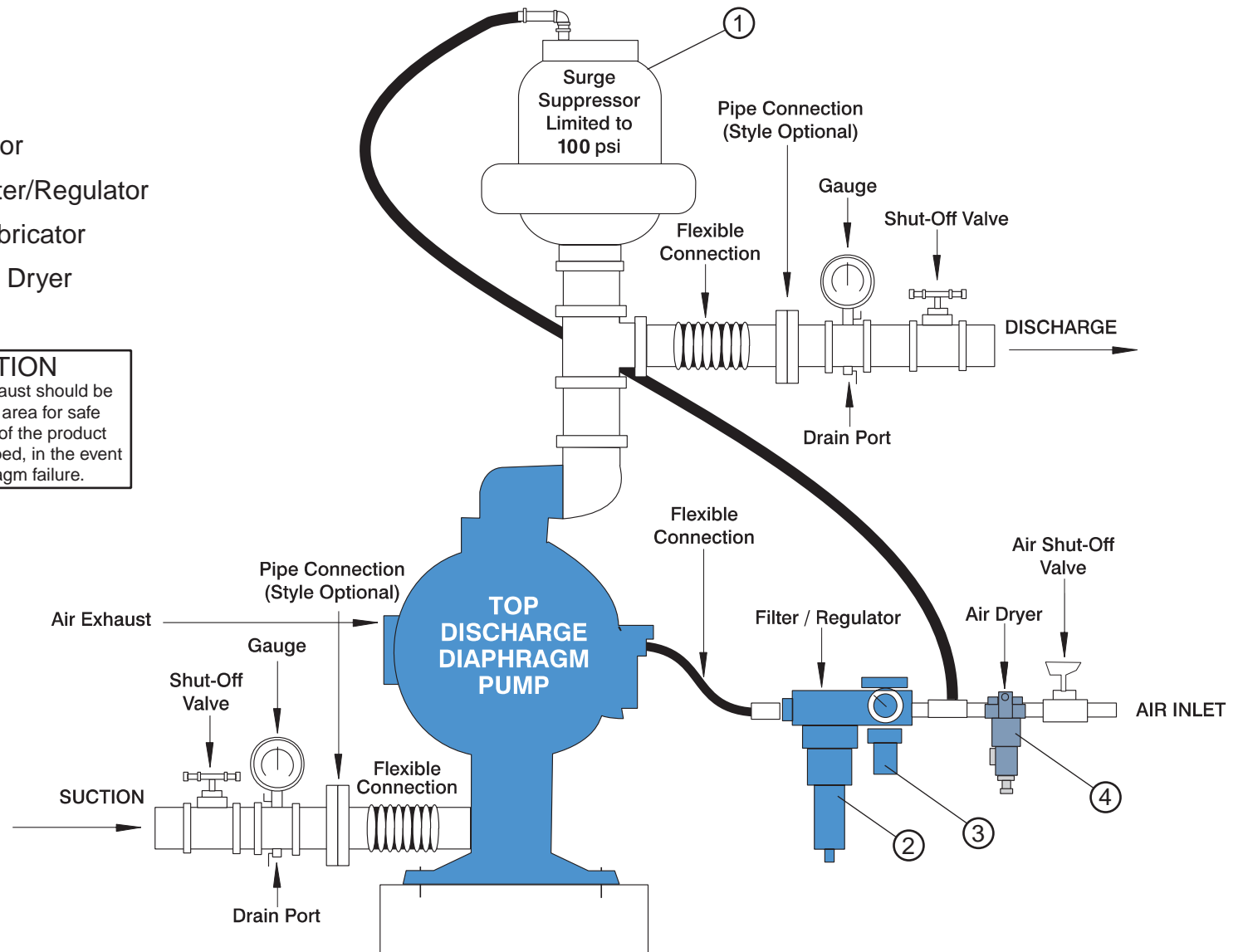

IMPORTANT SAFETY INFORMATION



IMPORTANT

Read these safety warnings and instructions in this manual completely, before installation and start-up of the pump. It is the responsibility of the purchaser to retain this manual for reference. Failure to comply with the recommendations stated in this manual will damage the pump, and void factory warranty.



WARNING

This pump is pressurized internally with air pressure during operation. Always make certain that all bolting is in good condition and that all of the correct bolting is reinstalled during assembly.



CAUTION

Before pump operation, inspect all gasketed fasteners for looseness caused by gasket creep. Re-torque loose fasteners to prevent leakage. Follow recommended torques stated in this manual.



WARNING

When used for toxic or aggressive fluids, the pump should always be flushed clean prior to disassembly.



WARNING

Before maintenance or repair, shut off the compressed air line, bleed the pressure, and disconnect the air line from the pump. The discharge line may be pressurized and must be bled of its pressure.



WARNING

Before doing any maintenance on the pump, be certain all pressure is completely vented from the pump, suction, discharge, piping, and all other openings and connections. Be certain the air supply is locked out or made non-operational, so that it cannot be started while work is being done on the pump. Be certain that approved eye protection and protective clothing are worn all times in the vicinity of the pump. Failure to follow these recommendations may result in serious injury or death.



WARNING

In the event of diaphragm rupture, pumped material may enter the air end of the pump, and be discharged into the atmosphere. If pumping a product which is hazardous or toxic, the air exhaust must be piped to an appropriate area for safe disposition.



WARNING

Airborne particles and loud noise hazards. Wear ear and eye protection.

MATERIAL CODES

The Last 3 Digits of Part Number

000 Assembly, sub-assembly; and some purchased items	368 Food Grade EPDM
010 Cast Iron	370 Butyl Rubber. Color coded: BROWN
012 Powered Metal	371 Philthane (Tuftane)
015 Ductile Iron	374 Carboxylated Nitrile
020 Ferritic Malleable Iron	375 Fluorinated Nitrile
025 Music Wire	378 High Density Polypropylene
080 Carbon Steel, AISI B-1112	405 Cellulose Fibre
100 Alloy 20	408 Cork and Neoprene
110 Alloy Type 316 Stainless Steel	425 Compressed Fibre
111 Alloy Type 316 Stainless Steel (Electro Polished)	426 Blue Gard
112 Alloy "C" (Hastelloy equivalent)	440 Vegetable Fibre
113 Alloy Type 316 Stainless Steel (Hand Polished)	465 Fibre
114 303 Stainless Steel	500 Delrin 500
115 302/304 Stainless Steel	501 Delrin 570
117 440-C Stainless Steel (Martensitic)	502 Conductive Acetal, ESD-800
120 416 Stainless Steel (Wrought Martensitic)	503 Conductive Acetal, Glass-Filled
123 410 Stainless Steel (Wrought Martensitic)	505 Acrylic Resin Plastic
148 Hardcoat Anodized Aluminum	506 Delrin 150
149 2024-T4 Aluminum	520 Injection Molded PVDF Natural color
150 6061-T6 Aluminum	540 Nylon
151 6063-T6 Aluminum	541 Nylon
152 2024-T4 Aluminum (2023-T351)	542 Nylon
154 Almag 35 Aluminum	544 Nylon Injection Molded
155 356-T6 Aluminum	550 Polyethylene
156 356-T6 Aluminum	551 Glass Filled Polypropylene
157 Die Cast Aluminum Alloy #380	552 Unfilled Polypropylene
158 Aluminum Alloy SR-319	553 Unfilled Polypropylene
159 Anodized Aluminum	555 Polyvinyl Chloride
162 Brass, Yellow, Screw Machine Stock	556 Black Vinyl
165 Cast Bronze, 85-5-5-5	570 Rulon II
166 Bronze, SAE 660	580 Ryton
170 Bronze, Bearing Type, Oil Impregnated	590 Valox
175 Die Cast Zinc	591 Nylatron G-S
180 Copper Alloy	592 Nylatron NSB
305 Carbon Steel, Gray Epoxy Coated	600 Virgin PTFE
306 Carbon Steel, Black PTFE Coated	601 PTFE (Bronze and moly filled)
307 Aluminum, Gray Epoxy Coated	602 Filled PTFE
308 Stainless Steel, Black PTFE Coated	603 Blue Gylon
309 Aluminum, Black PTFE Coated	604 Virgin PTFE
310 Kynar® Coated	607 Envelon
330 Zinc Plated Steel	606 Injected molded PFA
331 Chrome Plated Steel	610 Encapsulated Silicon
332 Aluminum, Electroless Nickel Plated	611 Encapsulated Viton
333 Carbon Steel, Electroless Nickel Plated	632 Neoprene/Hytrel
335 Galvanized Steel	633 Viton/PTFE
336 Zinc Plated Yellow Brass	634 EPDM/PTFE
337 Silver Plated Steel	637 PTFE, Viton
340 Nickel Plated	638 PTFE, Hytrel
342 Filled Nylon	639 Buna-N
353 Geolast; Color: Black	643 Santoprene®/EPDM
354 Injection Molded #203-40 Santoprene - Duro 40D +/-5; Color: RED	644 Santoprene®
355 Thermal Plastic		
356 Hytrel		
357 Injection Molded Polyurethane		
358 Ruppilon (Urethane Rubber). Color coded: PURPLE (Some Applications) (Compression Mold)		
359 Urethane Rubber		
360 Buna-N Rubber. Color coded: RED		
361 Buna-N		
363 Viton (Fluorel). Color coded: YELLOW		
364 E.P.D.M. Rubber. Color coded: BLUE		
365 Neoprene Rubber. Color coded: GREEN		
366 Food Grade Nitrile		

Delrin, Viton and Hytrel are registered tradenames of E.I. DuPont.

Gylon is a registered tradename of Garlock, Inc.

Nylatron is a registered tradename of Polymer Corp.

Santoprene is a registered tradename of Monsanto Corp.

Rulon II is a registered tradename of Dixon Industries Corp.

Hastelloy-C is a registered tradename of Cabot Corp.

Ryton is a registered tradename of Phillips Chemical Co.

Valox is a registered tradename of General Electric Co.

Kynar® is a registered tradename of ATOFINA Chemicals, Inc.

Warren Rupp, Ruppilon, SandPIPER, SandPIPER II, PortaPump, Tranquizer, RuppGUARD, RuppTech and SludgeMaster are registered tradenames of Warren Rupp, Inc.

TROUBLESHOOTING

Possible Symptoms:

- Pump will not cycle.
- Pump cycles, but produces no flow.
- Pump cycles, but flow rate is unsatisfactory.
- Pump cycle seems unbalanced.
- Pump cycle seems to produce excessive vibration.

What to Check: Excessive suction lift in system.

Corrective Action: For lifts exceeding 20 feet (6 meters), filling the pumping chambers with liquid will prime the pump in most cases.

What to Check: Excessive flooded suction in system.

Corrective Action: For flooded conditions exceeding 10 feet (3 meters) of liquid, install a back pressure device.

What to Check: System head exceeds air supply pressure.

Corrective Action: Increase the inlet air pressure to the pump. Most diaphragm pumps are designed for 1:1 pressure ratio at zero flow.

What to Check: Air supply pressure or volume exceeds system head.

Corrective Action: Decrease inlet air pressure and volume to the pump as calculated on the published PERFORMANCE CURVE. Pump is cavitating the fluid by fast cycling.

What to Check: Undersized suction line.

Corrective Action: Meet or exceed pump connection recommendations shown on the DIMENSIONAL DRAWING.

What to Check: Restricted or undersized air line.

Corrective Action: Install a larger air line and connection. Refer to air inlet recommendations shown in your pump's SERVICE MANUAL.

What to Check: Check ESADS, the Externally Serviceable Air Distribution System of the pump.

Corrective Action: Disassemble and inspect the main air distribution valve, pilot valve and pilot valve actuators. Refer to the parts drawing and air valve section of the SERVICE MANUAL. Check for clogged discharge or closed valve before reassembly.

What to Check: Rigid pipe connections to pump.

Corrective Action: Install flexible connectors and a surge suppressor.

What to Check: Blocked air exhaust muffler.

Corrective Action: Remove muffler screen, clean or de-ice and reinstall. Refer to the Air Exhaust section of your pump SERVICE MANUAL.

What to Check: Pumped fluid in air exhaust muffler.

Corrective Action: Disassemble pump chambers. Inspect for diaphragm rupture or loose diaphragm plate assembly. Refer to the Diaphragm Replacement section

of your pump SERVICE MANUAL.

What to Check: Suction side air leakage or air in product.

Corrective Action: Visually inspect all suction side gaskets and pipe connections.

What to Check: Obstructed check valve.

Corrective Action: Disassemble the wet end of the pump and manually dislodge obstruction in the check valve pocket. Refer to the Check Valve section of the pump SERVICE MANUAL for disassembly instructions.

What to Check: Worn or misaligned check valve or check valve seat.

Corrective Action: Inspect check valves and seats for wear and proper seating. Replace if necessary. Refer to Check Valve section of the pump SERVICE MANUAL for disassembly instructions.

What to Check: Blocked suction line.

Corrective Action: Remove or flush obstruction. Check and clear all suction screens and strainers.

What to Check: Blocked discharge line.

Corrective Action: Check for obstruction or closed discharge line valves.

What to Check: Blocked pumping chamber.

Corrective Action: Disassemble and inspect the wetted chambers of the pump. Remove or flush any obstructions. Refer to the pump SERVICE MANUAL

for disassembly instructions.

What to Check: Entrained air or vapor lock in one or both pumping chambers.

Corrective Action: Purge chambers through tapped chamber vent plugs. PURGING THE CHAMBERS OF AIR CAN BE DANGEROUS! Contact the Warren Rupp Technical Services Department before performing this procedure. A model with top-ported discharge will reduce or eliminate problems with entrained air.

If your pump continues to perform below your expectations, contact your local Warren Rupp Distributor or factory Technical Services Group for a service evaluation.

WARRANTY

Refer to the enclosed Warren Rupp Warranty Certificate.

Composite Repair Parts Drawing

AVAILABLE SERVICE AND CONVERSION KITS

- 476-172-000 AIR END KIT**
Seals, O-rings, Gaskets, Retaining Rings, Air Valve Sleeve & Spool Set and Pilot Valve Assembly
- 476-173-000* AIR END KIT (for Stroke Indicator Option)**
Seals, O-rings, Gaskets, Retaining Rings, Air Valve Sleeve & Spool Set and Pitot Valve Assembly.
- 476-124-354 WETTED END KIT**
Santoprene Diaphragms, Santoprene Balls and TFE Seals.
- 476-124-654 WETTED END KIT**
Santoprene Diaphragms, PTFE Overlay Diaphragms, TFE Balls and TFE Seals.
- 476-141-354 WETTED END KIT (for Polypropylene RuppGuard™)**
Santoprene Diaphragms, PTFE Overlay Diaphragms, PTFE Pumping Diaphragms, PTFE Balls and PTFE Seals.
- 476-141-655 WETTED END KIT (for PVDF RuppGuard™)**
Santoprene Diaphragms, PTFE Overlay Diaphragms, PTFE Pumping Diaphragms, PTFE Balls and PTFE Seals.
- 031-141-000 ASSEMBLY, AIR VALVE**
(without Encapsulated Muffler, Muffler Cap and six screws)
- HARDWARE KITS**
- 475-168-308** PTFE Coated Stainless Steel Capscrews, Hex Nuts, Washers and Support Rod
- 475-169-308** (For use with RuppGuard™ Spill Prevention Options)
- RuppTech® PULSE OUTPUT KITS**
(For use with 530-010-000 and 530-032-000 Mufflers, or piped exhaust)
- 475-198-001** DC Kit
- 475-198-002** DC Intrinsically Safe Kit
- 475-198-003** 110/120VAC or 220/240VAC Kit
- 475-198-004** 110/120VAC Intrinsically Safe Kit
- 475-198-005** 220/240VAC Intrinsically Safe Kit
(For use with encapsulated 530-028-550 Muffler)
- 475-198-006** DC Kit
- 475-198-007** DC Intrinsically Safe Kit
- 475-198-008** 110/120VAC or 220/240VAC Kit
- 475-198-009** 110/120VAC Intrinsically Safe Kit
- 475-198-010** 220/240VAC Intrinsically Safe Kit
- RuppTech® ELECTRONIC LEAK DETECTOR KITS**
- 032-037-000** 100VAC 50Hz or 110-120VAC 50-60Hz or 220-240VAC 50-60Hz
- 032-045-000** 12-32VDC

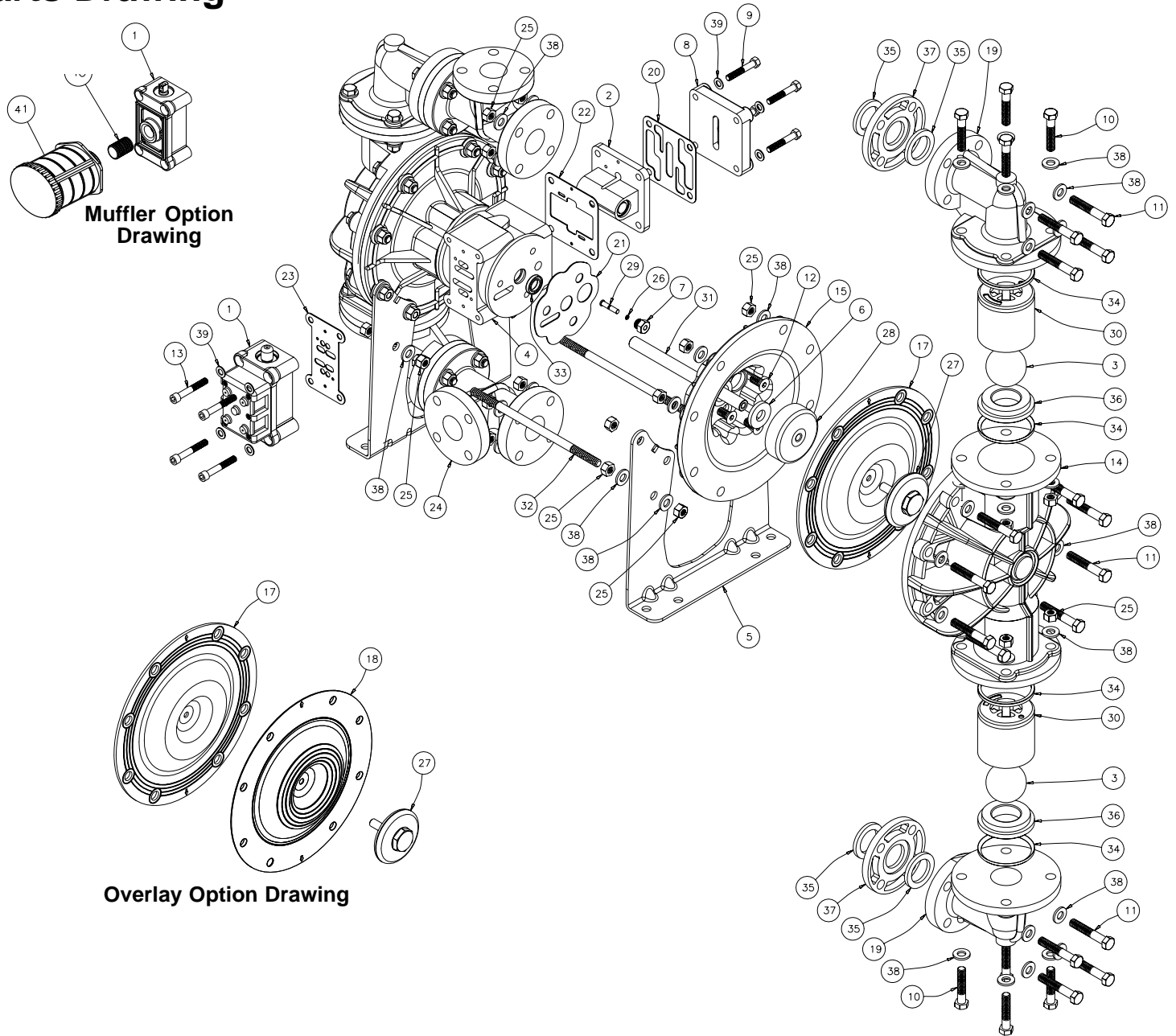

Composite Repair Parts List

ITEM	PART NUMBER	DESCRIPTION	QTY	ITEM	PART NUMBER	DESCRIPTION	QTY
1	031-140-000	Air Valve Assembly	1	21	360-091-360	Gasket, Inner Chamber	2
	031-140-002	Air Valve Assembly w/ PTFE coated Hardware	1	22	360-092-360	Gasket, Pilot Valve	1
	031-141-000	Air Valve Assembly (No Encapsulated Muffler)	1	23	360-093-360	Gasket, Main Air Valve	1
	031-141-002	Air Valve Assembly (No Muffler/ PTFE Hardware)	1	24	518-130-520	Manifold	2
	031-146-000	Air Valve Assembly (With Stroke Indicator Option)	1		518-130-520E	Manifold, 40mm DIN	2
	031-147-000	Air Valve Assembly (No Muffler w/ Stroke Indicator)	1		518-130-552	Manifold	2
2	095-088-000	Pilot Valve Assembly	1		518-130-552E	Manifold, 40mm DIN	2
3	050-036-354	Ball, Check	4	25	545-008-110	Nut, Hex 1/2-13	56
	050-036-357	Ball, Check	4		545-008-308	Nut, Hex 1/2-13	56
	050-036-600	Ball, Check	4	26	560-001-360	O-ring	2
4	114-021-156	Intermediate Assembly	1	27	612-179-520	Assembly, Outer Diaphragm Plate	2
	114-021-307	Intermediate Assembly	1		612-179-552	Assembly, Outer Diaphragm Plate	2
	114-021-309	Intermediate Assembly	1	28	612-158-150	Assembly, Inner Diaphragm Plate	2
5	115-131-080	Bracket, Mounting	2	29	620-017-115	Plunger, Actuator	2
	115-131-305	Bracket, Mounting	2	30	670-045-520	Retainer, Ball	4
	115-131-306	Bracket, Mounting	2		670-045-552	Retainer, Ball	4
	115-131-115	Bracket, Mounting (Optional)	2	31	685-050-120	Rod, Diaphragm	1
6	132-031-360	Bumper, Diaphragm	2	32	685-053-115	Rod, Support	2
7	135-032-506	Bushing, Plunger	2		685-053-308	Rod, Support	2
8	165-099-156	Cap, Air Inlet	1	33	720-010-375	Seal, Diaphragm Rod	2
	165-099-307	Cap, Air Inlet	1	34	720-035-600	Seal, Check Valve	8
	165-099-309	Cap, Air Inlet	1	35	720-037-600	Seal, Manifold Spacer	8
9	170-052-115	Capscrew, Hex HD 3/8-16 x 2.25	4	36	722-074-520	Seat, Check Valve	4
	170-052-308	Capscrew, Hex HD 3/8-16 x 2.25	4		722-074-552	Seat, Check Valve	4
10	170-055-115	Capscrew, Hex HD 1/2-13 x 2.50	16	37	770-052-520	Spacer, Manifold	4
	170-055-308	Capscrew, Hex HD 1/2-13 x 2.50	16		770-050-552	Spacer, Manifold	4
11	170-095-115	Capscrew, Hex HD 1/2-13 x 3.00	32	38	901-046-115	Washer, Flat 1/2"	96
	170-095-308	Capscrew, Hex HD 1/2-13 x 3.00	32		901-046-308	Washer, Flat 1/2"	96
12	171-004-115	Capscrew, Soc HD 1/2-13 x 1.25	6	39	901-048-115	Washer, Flat 3/8"	8
13	171-053-115	Capscrew, Soc HD 3/8-16 x 2.75	4		901-048-308	Washer, Flat 3/8"	8
	171-053-308	Capscrew, Soc HD 3/8-16 x 2.75	4	40	538-035-555	Nipple, Pipe 1" NPT Close	1
14	196-147-520	Chamber, Outer	2	41	530-010-000	Muffler	1
	196-147-552	Chamber, Outer	2				
15	196-148-156	Chamber, Inner	2		NOT SHOWN:		
	196-148-307	Chamber, Inner	2		535-069-000	Nameplate	
	196-148-309	Chamber, Inner	2				
17	286-074-354	Diaphragm, Overlay	2				
	286-074-357	Diaphragm	2				
18	286-075-600	Diaphragm, Overlay	2				
19	312-101-520	Elbow	4				
	312-101-552	Elbow	4				
20	360-090-360	Gasket, Air Inlet	1				

RuppGUARD™ Option for Virgin PTFE Equipped Pumps Drawing

S15 Spill Prevention Repair Parts List for Virgin PTFE Equipped Pumps

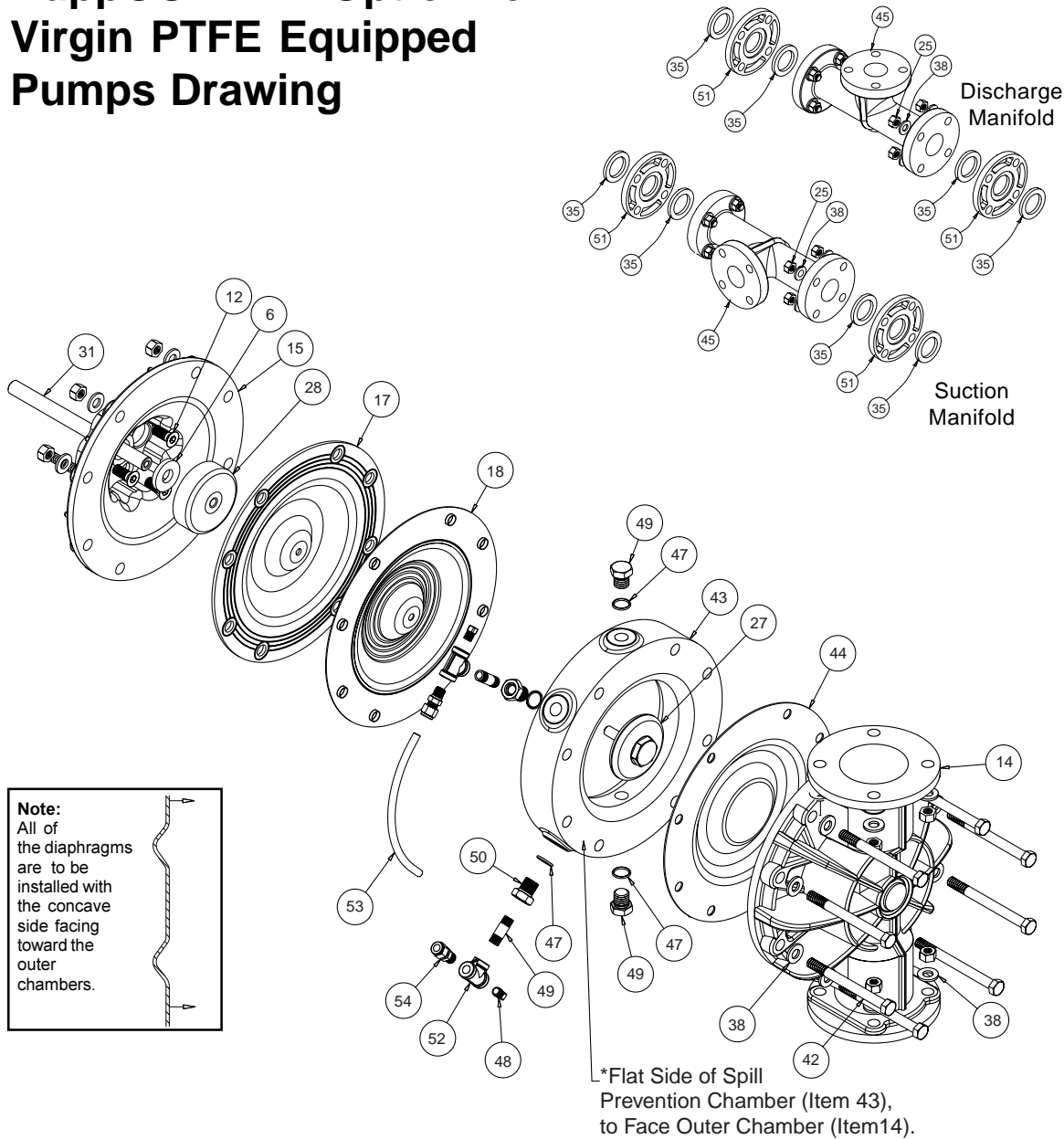

ITEM	PART NUMBER	DESCRIPTION	QTY
1	031-146-000	Air Valve Assembly (replaces 031-140-000)	1
	031-147-000	Air Valve Assembly (replaces 031-141-000)	1
2	095-093-000	Pilot Valve Assembly (replaces 095-088-000)	1
42	170-108-115	Capscrew, Hex HD 1/2-13 x 5.50	16
	170-108-308	Capscrew, Hex HD 1/2-13 x 5.50 (replaces 170-095-115 Qty 16 of 32)	16
43	196-149-520*	Chamber, Spill Prevention	2
	196-149-552*	Chamber, Spill Prevention	2
44	286-076-600	Diaphragm, Pumping	2
45	518-131-520	Manifold (replaces 518-130-xxx)	2
	518-131-520E	Manifold, 40mm DIN	2
	518-131-552	Manifold (replaces 518-130-xxx)	2
	518-131-552E	Manifold, 40mm DIN	2
46	538-022-110	Nipple, Pipe	4
	538-022-308	Nipple, Pipe	4
47	560-078-611	O-Ring	8
48	618-003-110	Plug, Pipe	4
	618-003-308	Plug, Pipe	4
49	618-025-110	Plug, Boss	4
	618-025-308	Plug, Boss	4
50	618-031-110	Plug, Boss	4
	618-031-308	Plug, Boss	4
51	770-052-600	Spacer, Manifold	4
	770-052-552	Spacer, Manifold	4
52	835-055-110	Tee, Pipe	4
	835-055-308	Tee, Pipe	4
53	860-055-606	Tube, Sight	2
54	866-060-110	Connector, Tube	4

Note: The diaphragms are to be installed with the concave side facing toward the outer chambers. See drawing.

RuppGUARD™ FOR VIRGIN PTFE EQUIPPED PUMPS CONCEPT

The spill prevention option prevents the air end components from being contaminated or damaged when a pumping diaphragm ruptures while pumping caustic or toxic materials. It also helps to protect the environment. With the installation of optional leak detectors (either mechanical or electronic) the diaphragm rupture can be detected. The pump can then be shut down and repaired before any caustic or toxic materials can enter the air end and be exhausted into the surrounding environment.

RuppGUARD™ OPTION DIAPHRAGM SERVICING

To service the diaphragms first shut off the suction, then shut off the discharge lines to the pump. Next shut off the compressed air supply, bleed the pressure from the pump, and disconnect the air supply line from the pump. Drain any remaining pumped liquid from the pump. Remove the pump before servicing.

Next, drain the fluid from the spill prevention chambers. This can be done by removing the bottom plug (item 49) from each spill prevention chamber.

After the fluid from the spill prevention chambers has been drained, the wet end components can now be removed. See diaphragm servicing section for detailed instructions. The spill prevention option has two additional virgin PTFE pumping diaphragms (item 44). These diaphragms are installed with the natural **concave** curve toward the outer chamber (items

14 from the pump assembly drawing). The molded directional arrows on the diaphragms must point vertically.

FILLING RuppGUARD™ CHAMBERS WITH LIQUID

THE CHAMBERS ARE FILLED WITH WATER AT THE FACTORY.

If you prefer to substitute another liquid, to prevent system contamination consult the factory first to determine compatibility of the substitute with pump construction.

Follow the steps listed here to replace the liquid in the pump after disassembly or liquid loss:

1. Drain the fluid in the spill prevention chambers by removing the bottom two boss plugs (items 49). Replace the bottom two boss plugs after the fluid is drained.

2. Remove the eight capscrews (item 10) fastening the discharge manifold and elbows to the outer chambers (items 14). The discharge manifolds and elbows can now be removed.

3. Remove the top two boss plugs (items 49). The spill prevention chambers are filled through the exposed ports.

4. Apply air pressure to the air distribution valve. Install safety clip (item 1-N) into the smaller unthreaded hole in one end cap (item 1-D). This locks the valve spool to one side, keeping the pump from shifting.

5. Face the side of the pump with the installed safety clip. If the safety clip is installed in the top end cap, fill the left spill containment chamber. If the safety clip is installed on the bottom end

cap, fill the right spill prevention chamber. The volume of fluid is 1420 ml (48.01 fl. oz.). It is important that the exact amount of fluid is used. Too little or too much fluid causes premature diaphragm failure and erratic pumping.

6. Loosely reinstall one boss plug (item 49) to the filled spill prevention chamber.

7. Shut off air supply. Remove safety clip. Adjust the air line regulator so that air pressure slowly fills the pump. The diaphragm expands, forcing the fluid in the chamber to be slowly displaced. When the pump shifts to the opposite side, quickly install the safety clip.

8. Loosen the top boss plug on the filled chambers. This allows fluid in the chamber to purge trapped air from the chamber. This can be seen by watching the column of fluid in the sight tube. When fluid appears at the top of the port, quickly tighten the boss plug. Fluid loss of 1 to 2ml is acceptable.

9. Tilt the pump so the uppermost pipe tee (item 52) is in the vertical position. Loosen the pipe plug (item 48). This will allow trapped air to purge through the pipe tee. When fluid appears at the tee opening, reinstall the pipe plug.

NOTE: If all air is not purged using this procedure, remove the check valve components from the top port of the outer chamber (item 14). Apply manual pressure to the pumping diaphragm by inserting a blunt instrument into the top port of the outer chamber and applying pressure to the diaphragm. Loosen the pipe plug (item 48) allowing the fluid to

purge any remaining trapped air. Reinstall the plug.

10. Repeat steps 5 through 9 to fill opposite spill prevention chamber.

11. Reinstall the check valve components, discharge manifold and elbows to the pump. The pump is now ready for operation.



▲ IMPORTANT

Read these instructions completely, before installation and start-up. It is the responsibility of the purchaser to retain this manual for reference. Failure to comply with the recommendations stated in this manual will damage the pump, and void factory warranty.

RuppGUARD™ Option for TPE Equipped Pumps Drawing

S15 Spill Prevention for TPE Equipped Pumps Repair Parts List

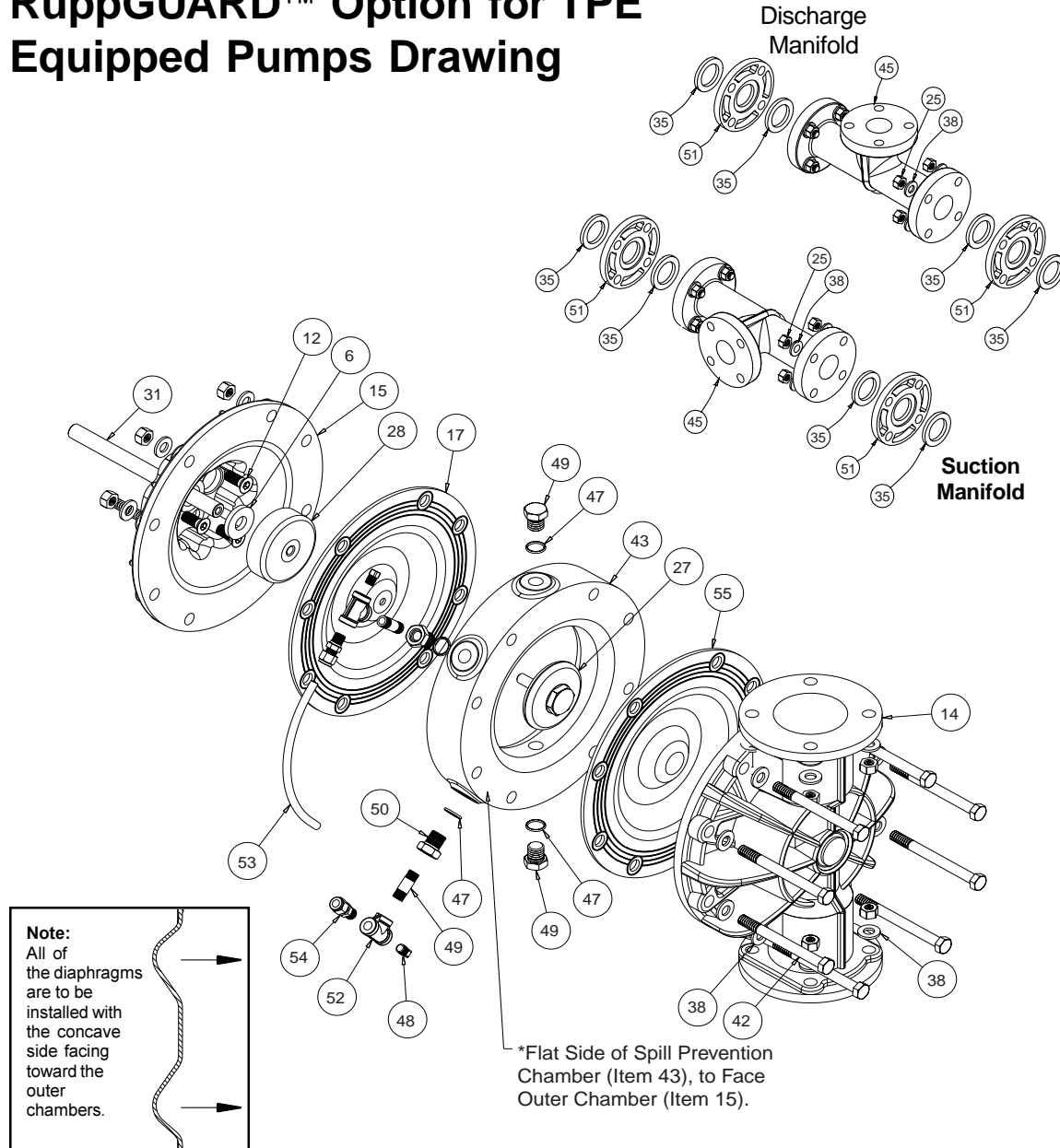

ITEM	PART NUMBER	DESCRIPTION	QTY
1	031-146-000	Air Valve Assembly (replaces 031-140-000)	1
	031-147-000	Air Valve Assembly (replaces 031-141-000)	1
42	170-108-115	Capscrew, Hex HD 1/2-13 x 5.50	16
	170-108-308	Capscrew, Hex HD 1/2-13 x 5.50 (replaces 170-095-115 Qty 16 of 32)	16
43	196-149-520*	Chamber, Spill Prevention	2
	196-149-552*	Chamber, Spill Prevention	2
45	518-131-520	Manifold	2
		(replace 518-130-xxx)	
	518-131-520E	Manifold, 40mm DIN	2
	518-131-552	Manifold (replaces 518-130-xxx)	2
		Manifold, 40mm DIN	2
46	538-022-110	Nipple, Pipe	4
	538-022-308	Nipple, Pipe	4
47	560-078-611	O-Ring	8
48	618-003-110	Plug, Pipe	4
	618-003-308	Plug, Pipe	4
49	618-025-110	Plug, Boss	4
	618-025-308	Plug, Boss	4
50	618-031-110	Plug, Boss	4
	618-031-308	Plug, Boss	4
51	770-052-600	Spacer, Manifold	4
	770-052-552	Spacer, Manifold	4
52	835-005-110	Tee, Pipe	4
	835-055-308	Tee, Pipe	4
53	860-056-606	Tube, Sight	2
54	866-060-110	Connector, Tube	4
55	286-081-354	Diaphragm, Pumping	2

Note: The diaphragms are to be installed with the concave side facing toward the outer chambers. See drawing.

RuppGUARD™ FOR TPE EQUIPPED PUMPS CONCEPT

The spill prevention option prevents the air end components from being contaminated or damaged when a pumping diaphragm ruptures while pumping caustic or toxic materials. It also helps to protect the environment. With the installation of optional leak detectors (either mechanical or electronic) the diaphragm rupture can be detected. The pump can then be shut down and repaired before any caustic or toxic materials can enter the air end and be exhausted into the surrounding environment.

RuppGUARD™ OPTION DIAPHRAGM SERVICING

To service the diaphragms first shut off the suction, then shut off the discharge lines to the pump. Next shut off the compressed air supply, bleed the pressure from the pump, and disconnect the air supply line from the pump. Drain any remaining pumped liquid from the pump. Remove the pump before servicing.

Next, drain the fluid from the spill prevention chambers. This can be done by removing the bottom plug (item 49) from each spill prevention chamber.

After the fluid from the spill prevention chambers has been drained, the wet end components can now be removed. See diaphragm servicing section for detailed instructions. The spill prevention option has two additional TPE pumping diaphragms (item 55). These diaphragms are installed with the natural **concave** curve toward the outer chamber (items

14 from the pump assembly drawing). The molded directional arrows on the diaphragms must point vertically.

FILLING RuppGUARD™ CHAMBERS WITH LIQUID

THE CHAMBERS ARE FILLED WITH WATER AT THE FACTORY.

If you prefer to substitute another liquid, to prevent system contamination consult the factory first to determine compatibility of the substitute with pump construction.

Follow the steps listed here to replace the liquid in the pump after disassembly or liquid loss:

1. Drain the fluid in the spill prevention chambers by removing the bottom two boss plugs (items 49). Replace the bottom two boss plugs after the fluid is drained.

2. Remove the eight capscrews (item 10) fastening the discharge manifold and elbows to the outer chambers (items 14). The discharge manifolds and elbows can now be removed.

3. Remove the top two boss plugs (items 49). The spill prevention chambers are filled through the exposed ports.

4. Apply air pressure to the air distribution valve. Install safety clip (item 1-N) into the smaller unthreaded hole in one end cap (item 1-D). This locks the valve spool to one side, keeping the pump from shifting.

5. Face the side of the pump with the installed safety clip. If the safety clip is installed in the top end cap, fill the left spill prevention chamber. If the safety clip is installed on the bottom end cap,

fill the right spill prevention chamber.

6. Loosely reinstall one boss plug (item 49) to the filled spill prevention chamber.

7. Shut off air supply. Remove safety clip. Adjust the air line regulator so that air pressure slowly fills the pump. The diaphragm expands, forcing the fluid in the chamber to be slowly displaced. When the pump shifts to the opposite side, quickly install the safety clip.

8. Loosen the top boss plug on the filled chambers. This allows fluid in the chamber to purge trapped air from the chamber. This can be seen by watching the column of fluid in the sight tube. When fluid appears at the top of the port, quickly tighten the boss plug. Fluid loss of 1 to 2ml is acceptable.

9. Tilt the pump so the uppermost pipe tee (item 52) is in the vertical position. Loosen the pipe plug (item 48). This will allow trapped air to purge through the pipe tee. When fluid appears at the tee opening, reinstall the pipe plug.

NOTE: If all air is not purged using this procedure, remove the check valve components from the top port of the outer chamber (item 14). Apply manual pressure to the pumping diaphragm by inserting a blunt instrument into the top port of the outer chamber and applying pressure to the diaphragm. Loosen the pipe plug (item 48) allowing the fluid to purge any remaining trapped air. Reinstall the plug.

10. Repeat steps 5 through 9 to fill opposite spill prevention chamber.

11. Reinstall the check valve components, discharge manifold and elbows to the pump. The pump is now ready for operation.

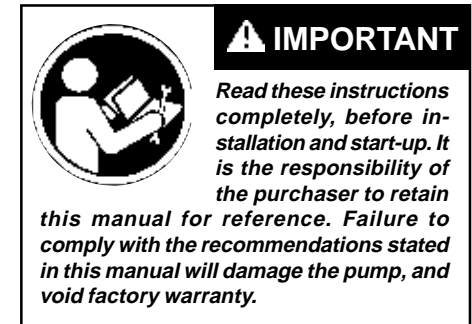

Air Distribution Valve Assembly Drawing

S15 Design Level 2

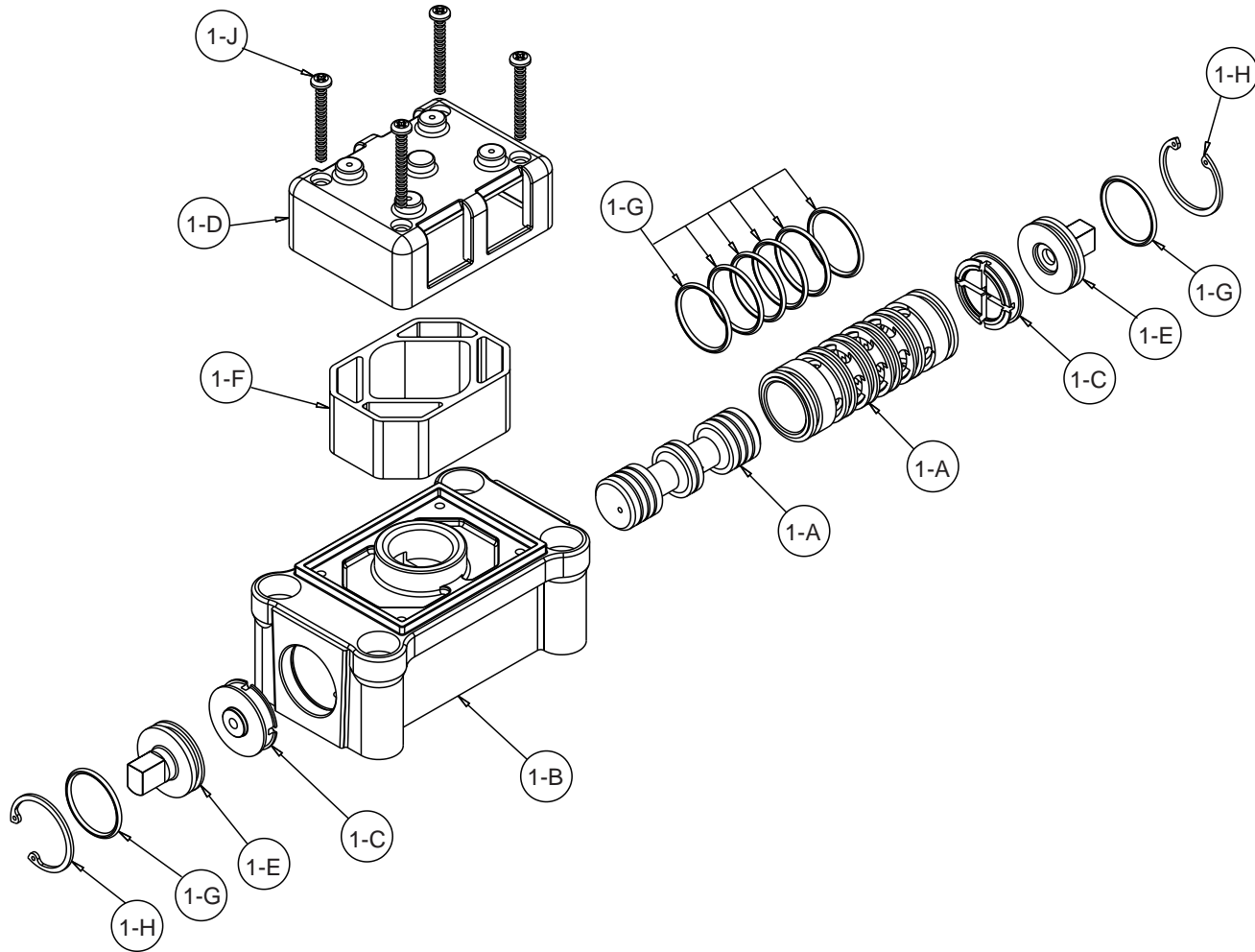

Main Air Valve Assembly Parts List

ITEM	PART NUMBER	DESCRIPTION	QTY
1	031-140-000	Main Air Valve Assembly	1
1-A	031-139-000	Spool Assembly	1
1-B	095-094-551	Body, Air Valve	1
1-C	132-029-552	Bumper	2
1-D	165-096-551	Cap, Muffler	1
1-E	165-115-552	Cap, End	2
1-F	530-028-550	Muffler	1
1-G	560-020-360	O-Ring	8
1-H	675-044-115	Ring, Retaining	2
1-J	710-015-115	Screw, Self-tapping	4

For pumps equipped with PTFE Coated Hardware

1	031-140-002	Air Valve Assembly (Includes all items used on 031-155-000 except:)	1
1-H	675-055-308	Ring, Retaining	2
1-J	710-015-308	Screw Self tapping	4

For pumps equipped with PTFE coated hardware option:

1	031-141-000	Air Valve Assembly (Includes all items used on 031-155-000 minus items 1-D, 1-F & 1-J)	1
---	-------------	---	---

For pumps with alternate Mesh or Sound Dampening mufflers or piped exhaust:

1	031-156-002	Air Valve Assembly (Includes all items used on 031-156-000 except:)	1
1-H	675-055-308	Ring, Retaining	2

AIR DISTRIBUTION VALVE SERVICING

To service the air valve first shut off the compressed air, bleed the pressure from the pump, and disconnect the air supply line from the pump.

STEP #1: See Composite Repair and Parts Drawing.

Using a $\frac{5}{16}$ " Allen wrench, remove the four hex socket capscrews (item 13) and four flat washers (item 39). Remove the air valve assembly from the pump.

Remove and inspect gasket (item 23) for cracks or damage. Replace gasket if needed.

STEP #2: Disassembly of the air valve.

To access the internal air valve components first remove the two retaining rings (item 1-H) from each end of the air valve assembly using clip ring pliers.

Next remove the two end caps (item 1-E). Inspect the o-rings (item 1-G) for cuts or wear. Replace the o-rings if necessary.

Remove the two bumpers (item 1-C). Inspect the bumpers for cuts, wear or abrasion. Replace if necessary.

Remove the spool (part of item 1-A) from the sleeve. Be careful not to scratch or damage the outer diameter of the spool. Wipe spool with a soft cloth and inspect for scratches or wear.

Inspect the inner diameter of the sleeve (part of item 1-A) for dirt, scratches, or other contaminants. Remove the sleeve if needed and replace both the sleeve and spool with a new sleeve and spool set (item 1-A).

STEP #3: Reassembly of the air valve.

Install one end cap (item 1-E) with an o-ring (item 1-G) and one bumper (item 1-C) into one end of the air valve body (item 1-B). Install one retaining ring (item 1-H) into the groove on the same end.

Remove the new sleeve and spool set (item 1-A) from the plastic bag. Carefully remove the spool from the sleeve. Install the six o-rings (item 1-G) into the six grooves on the sleeve. Apply a light coating of grease to the o-rings before installing the sleeve into the valve body (item 1-B), align the slots in the sleeve with the slots in the valve body. Insert the spool into the sleeve. Be careful not to scratch or damage the spool during installation. Push the spool in until it touches the bumper on the opposite end.

Install the remaining bumper, end cap with o-ring, and retaining ring.

Fasten the air valve assembly (item 1) and gasket (item 23) to the pump.

Connect the compressed air line to the pump. The pump is now ready for operation.



! IMPORTANT

Read these instructions completely, before installation and start-up. It is the responsibility of the purchaser to retain this manual for reference. Failure to comply with the recommendations stated in this manual will damage the pump, and void factory warranty.

Air Valve Assembly Drawing with Stroke Indicator Option

S15 Design Level 2

Note: Stroke Indicator is standard on RuppGUARD™ Spill Prevention models

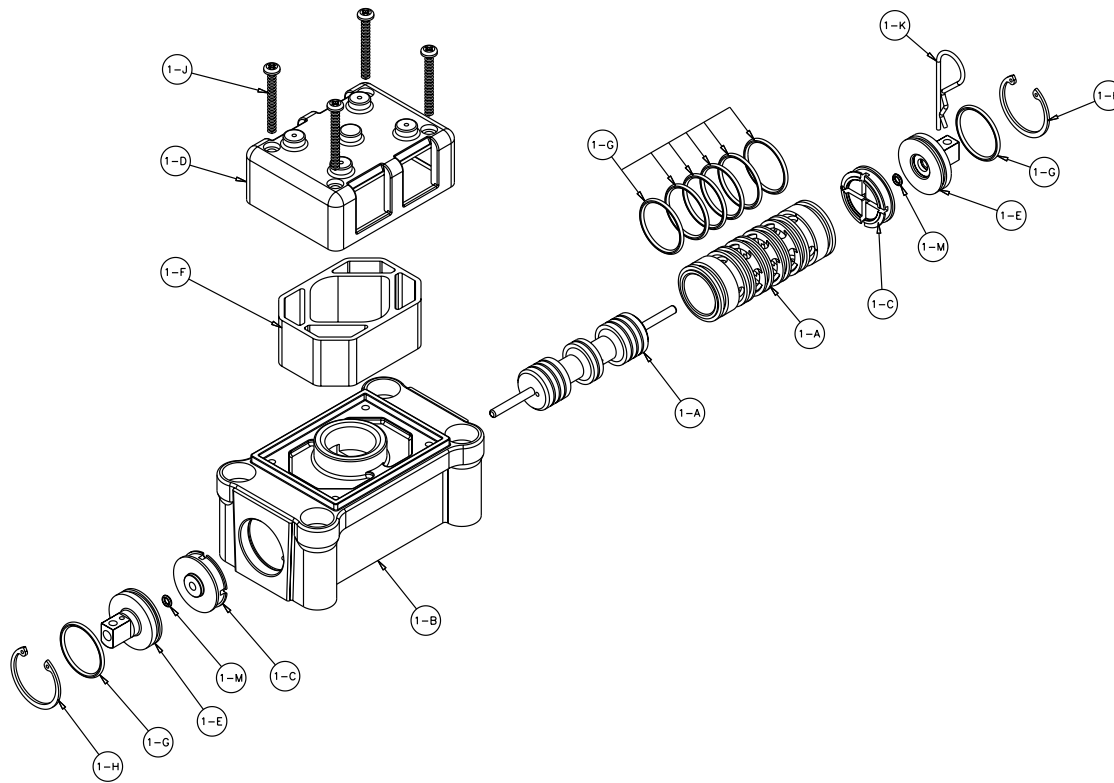

Pilot Valve Assembly Parts List

ITEM	PART NUMBER	DESCRIPTION	QTY
1	031-146-000	Air Valve Assembly	1
1-A	031-143-000	Sleeve and Spool Set w/Pins	1
1-B	095-094-551	Body, Air Valve	1
1-C	132-029-552	Bumper	2
1-D	165-096-551	Cap, Muffer	1
1-E	165-098-147	Cap, End	2
1-F	530-028-550	Muffer	1
1-G	560-020-360	O-Ring	8
1-H	675-044-115	Ring, Retaining	2
1-J	710-015-115	Screw, Self-Tapping	4
1-K	210-008-330	Clip, Safety	1
1-M	560-029-360	O-Ring	2

For Pumps with PTFE Coated Hardware:

1	031-146-002	Air Valve Assembly	1
1-J	710-015-308	Screw, Self Tapping	4

(includes all other items on 031-146-000 above.)

For Pumps with Alternate Mesh, Sound Dampening Mufflers or Piped Exhaust:

1	031-147-000	Air Valve Assembly	1
---	-------------	--------------------	---

(includes all items on 031-146-000 minus 1-D, 1-F, & 1-J)

AIR DISTRIBUTION VALVE WITH STROKE INDICATOR OPTION SERVICING

To service the air valve first shut off the compressed air, bleed the pressure from the pump, and disconnect the air supply line from the pump.

STEP #1: See Composite Repair and Parts Drawing.

Using a $\frac{5}{16}$ " Allen wrench, remove the four hex socket capscrews (item 13) and four flat washers (item 39). Remove the air valve assembly from the pump.

Remove and inspect gasket (item 23) for cracks or damage. Replace gasket if needed.

STEP #2: Disassembly of the air valve.

To access the internal air valve components first remove the two retaining rings (item 1-H) from each end of the air valve assembly using clip ring pliers.

Next remove the two end caps (item 1-E). Inspect the o-rings (item 1-G) for cuts or wear. Replace the o-rings if necessary.

Remove the two bumpers (item 1-C). Inspect the bumper for cuts, wear or abrasions. Replace if necessary.

Remove the spool (part of item 1-A) from the sleeve. Be careful not to scratch or damage the outer diameter of the spool. Wipe spool with a soft cloth and inspect for scratches or wear.

Inspect the inner diameter of the sleeve (part of item 1-A) for dirt, scratches, or other contaminants. Remove the sleeve if needed and replace both the sleeve and spool with a new sleeve and spool set (item 1-A).

STEP #3: Reassembly of the air valve.

Install one bumper (item 1-C) and one end cap (item 1-E) with an o-ring (item 1-G) into one end of the air valve body (item 1-B). Install one retaining ring (item 1-H) into the groove on the same end. Insert the safety clip (item 1-K) through the small unthreaded hole in the end cap.

Remove the new sleeve and spool set (item 1-A) from the plastic bag. Carefully remove the spool from the sleeve. Install the six o-rings (item 1-G) into the six grooves on the sleeve. Apply a light coating of grease to the o-rings before installing the sleeve into the valve body (item 1-B), align the slots in the sleeve with the slots in the valve body. Insert the spool into the sleeve. Be careful not to scratch or damage the spool during installation. Push the spool in until the pin touches the safety clip on the opposite end.

Install the remaining bumper, end cap with o-ring, and retaining ring.

Fasten the air valve assembly (item 1) and gasket (item 23) to the pump.

Connect the compressed air line to the pump. The pump is now ready for operation.



IMPORTANT

Read these instructions completely, before installation and start-up. It is the responsibility of the purchaser to retain this manual for reference. Failure to comply with the recommendations stated in this manual will damage the pump, and void factory warranty.

Solenoid Shifted Air Valve Drawing

SOLENOID SHIFTED AIR VALVE PARTS LIST

(Includes all items used on Composite Repair Parts List except as shown)

ITEM	PART NUMBER	DESCRIPTION	QTY
56	893-097-000	Solenoid Valve, NEMA4	1
57	219-001-000	Solenoid Coil, 24VDC	1
	219-004-000	Solenoid Coil, 24VAC/12VDC	1
	219-002-000	Solenoid Coil, 120VAC	1
	219-003-000	Solenoid Coil, 240VAC	1
58	241-001-000	Connector, conduit	1
59	170-061-115	Capscrew, Hex HD 3/8-16 x 1.75	4
60	618-052-506	Plug	2

For Explosion Proof Solenoid Valve

(Connector not required for explosion proof coil; coil is integral with valve)

56	893-098-001	Solenoid Valve, NEMA 7/9, 24VDC	1
	893-098-002	Solenoid Valve, NEMA 7/9, 24VAC/12VDC	1
	893-098-003	Solenoid Valve, NEMA 7/9, 120VAC	1
	893-098-004	Solenoid Valve, NEMA 7/9, 220VAC	1

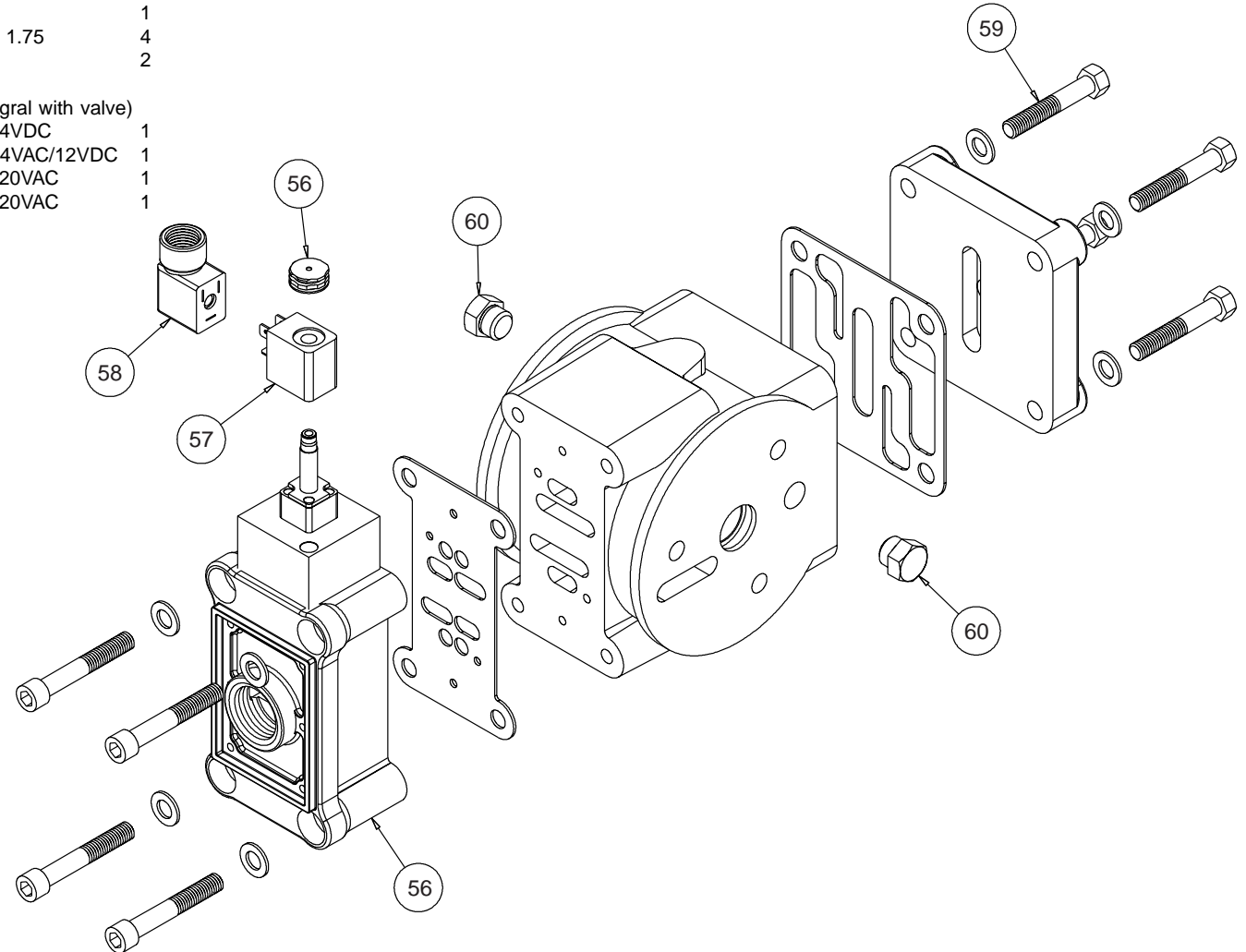

SOLENOID SHIFTED AIR DISTRIBUTION VALVE OPTION

Warren Rupp's solenoid shifted, air distribution valve option utilizes electrical signals to precisely control your SandPIPER's speed. The solenoid coil is connected to the Warren Rupp Solenoid Rate Controller/ Batch Control, or a customer - supplied control. Compressed air provides the pumping power, while electrical signals control pump speed (pumping rate).

OPERATION

The Solenoid Shifted SandPIPER has a solenoid operated, air distribution valve in place of the standard SandPIPER's pilot operated, air distribution valve. Where a pilot valve is normally utilized to cycle the pump's air distribution valve, an electric solenoid is utilized. As the solenoid is powered, one of the pump's air chambers is pressurized while the other chamber is exhausted. When electric power is turned off, the solenoid shifts and the pressurized chamber is exhausted while the other chamber is pressurized. By alternately applying and removing power to the solenoid, the pump cycles much like a standard SandPIPER pump, with one exception. This option provides a way to precisely control and monitor pump speed.

BEFORE INSTALLATION

Before wiring the solenoid, make certain it is compatible with your system voltage.

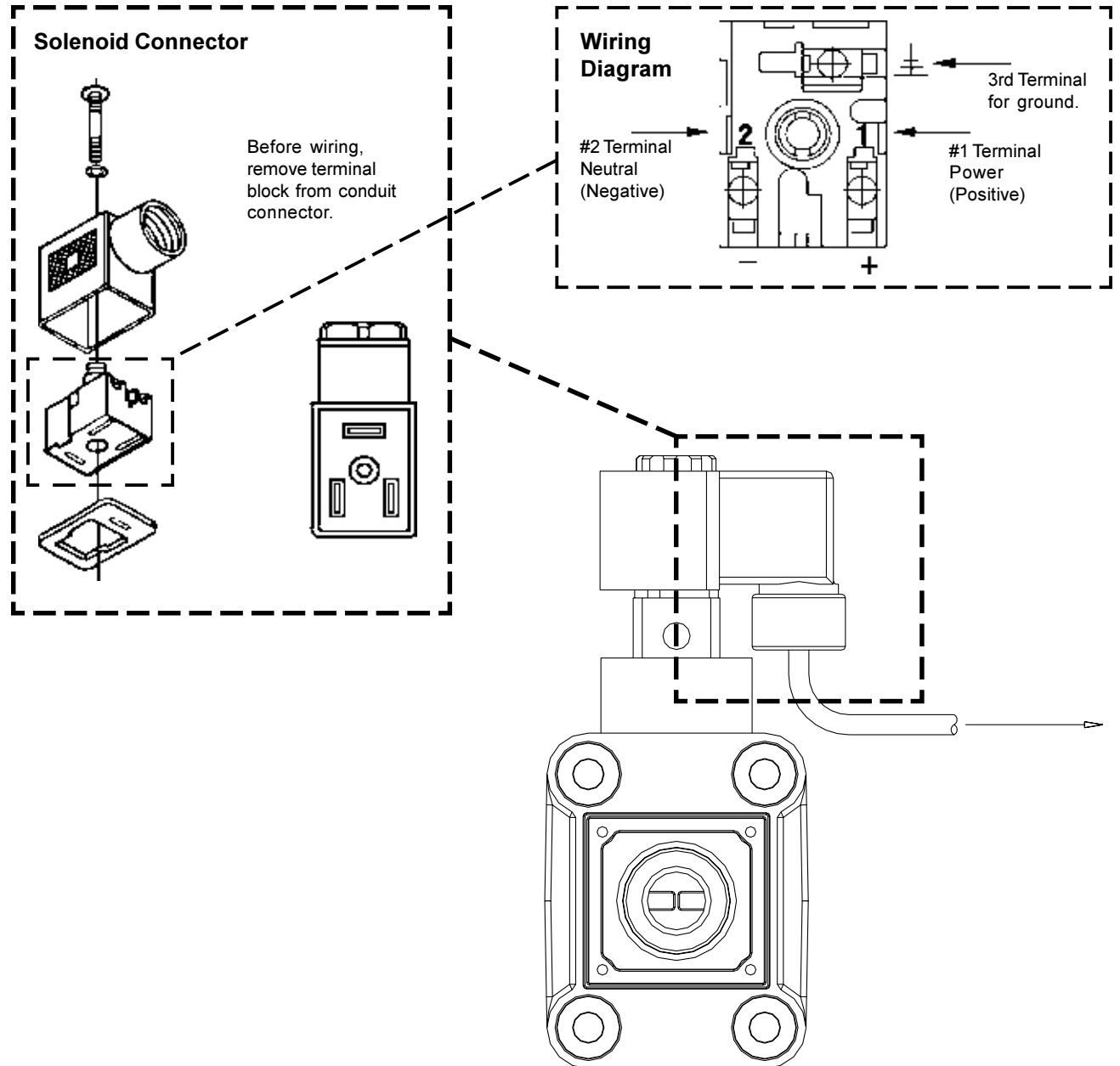

Pilot Valve Assembly Drawing

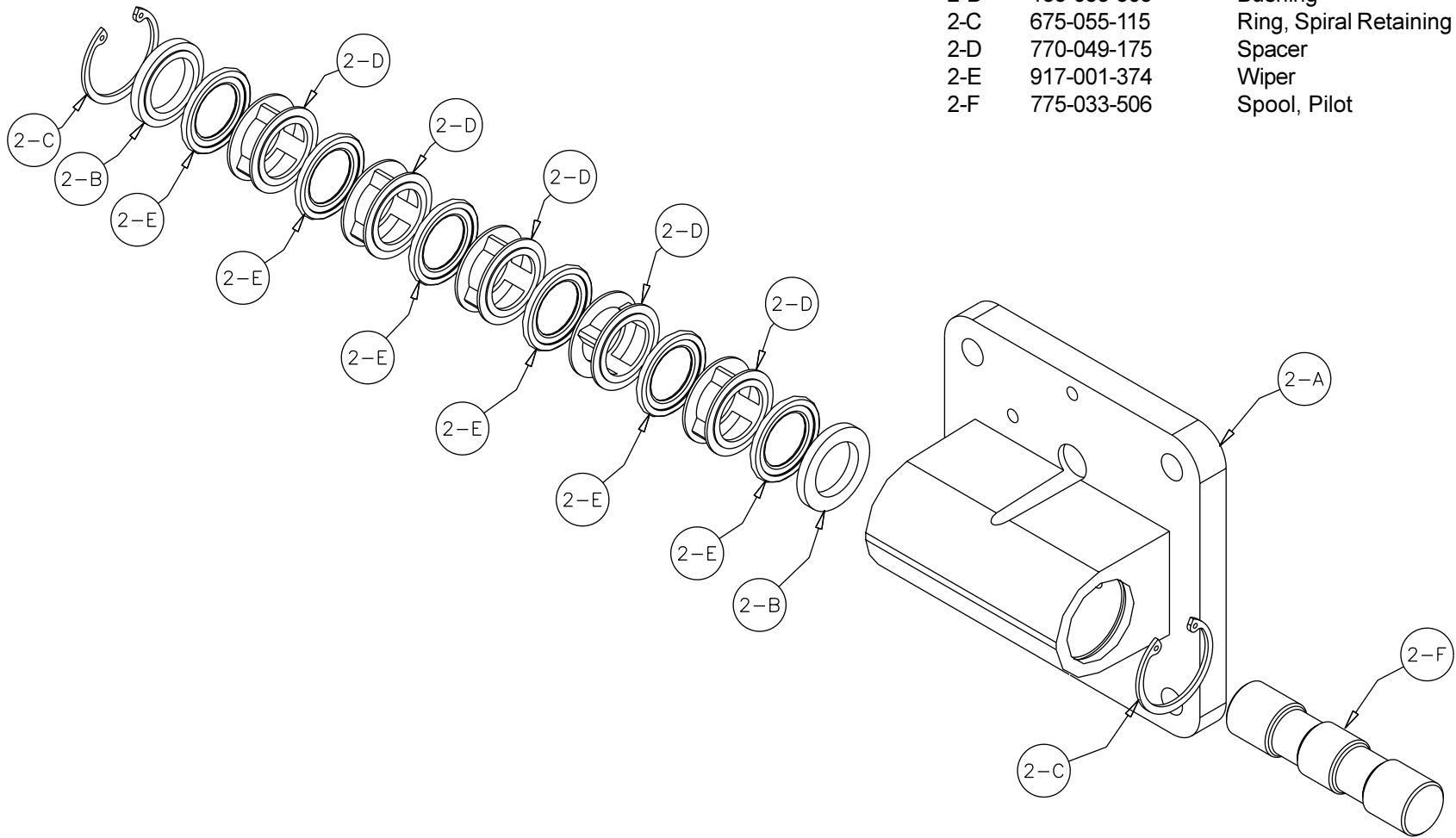

Pilot Valve Assembly Parts List

ITEM	PART NUMBER	DESCRIPTION	QTY
2	095-088-000	Pilot Valve Assembly	
2-A	095-081-551	Body, Pilot Valve	1
2-B	135-033-506	Bushing	2
2-C	675-055-115	Ring, Spiral Retaining	2
2-D	770-049-175	Spacer	5
2-E	917-001-374	Wiper	6
2-F	775-033-506	Spool, Pilot	1

PILOT VALVE SERVICING

To service the pilot valve first shut off the compressed air supply, bleed the pressure from the pump, and disconnect the air supply line from the pump. Insert the safety clip (item 1-N from Air Distribution Valve assembly drawing) into the smaller unthreaded holes in the end cap (item 1-C from air distribution valve assembly drawing).

Step #1: See PUMP ASSEMBLY DRAWING.

Using a $\frac{9}{16}$ " wrench or socket, remove the four capscrews (items 9) and four flat washers (items 39). Remove the air inlet cap (item 8) and air inlet gasket (item 20). The pilot valve assembly (item 2) can now be removed for inspection or service.

Step #2: Disassembly of the pilot valve.

Remove the pilot valve spool (item 2-F). Wipe clean, and inspect for dirt, scratches or wear. Replace the spool if necessary.

Remove the two retaining rings (items 2-C) from each end of the pilot valve body using clip ring pliers.

Remove the two pilot valve bushings (items 2-B), five spacers (items 2-D), and six spool wipers (items 2-F) by pushing gently from other end of the pilot valve body. Inspect the wipers for cuts and/or wear. Replace any wipers as necessary.

Step #3: Re-assembly of the pilot valve.

First install a spiral retaining ring to

one end of the pilot valve body. Install one bushing making sure the step side faces toward the wiper. Apply a light coating of grease to the outside diameter of each wiper. Next, gently push in the wipers and spacers until they are against the installed retaining ring in the opposite end of the pilot valve body. Install the remaining bushing making sure the step side faces the wiper. Install the remaining retaining ring using clip ring pliers.

Apply a light coating of grease to the inner diameter of each wiper. Also apply a light coating of grease to the outer diameter of the pilot valve spool and gently push the spool through each wiper.

Step #4: Inspect the actuator plungers.

See PUMP ASSEMBLY DRAWING.

The actuator plungers (items 29) can be reached through the stem cavity of the pilot valve in the intermediate assembly (item 4).

Remove the plungers (items 29) from the bushings (item 7) in each end of the cavity. Inspect the installed o-ring (items 26) for cuts and/or wear. Replace the o-rings if necessary. Apply a light coating of grease to each o-ring and re-install the plungers in to the bushings. Push the plungers in as far as they will go.

Step #5: Re-install the pilot valve assembly into the intermediate assembly.

Be careful to align the ends of the stem between the plungers when inserting the stem of the pilot valve into the cavity of the intermediate.

Re-install the gasket (item 20), air inlet cap (item 8), capscrews and washers (items 9 and 39).

Connect the air supply to the pump. Remove the safety clip (item 1-N) from the end cap (item 1-C). The pump is now ready for operation.

	IMPORTANT
<p><i>Read these instructions completely, before installation and start-up. It is the responsibility of the purchaser to retain this manual for reference. Failure to comply with the recommendations stated in this manual will damage the pump, and void factory warranty.</i></p>	

Diaphragm Service Drawing, Non-Overlay

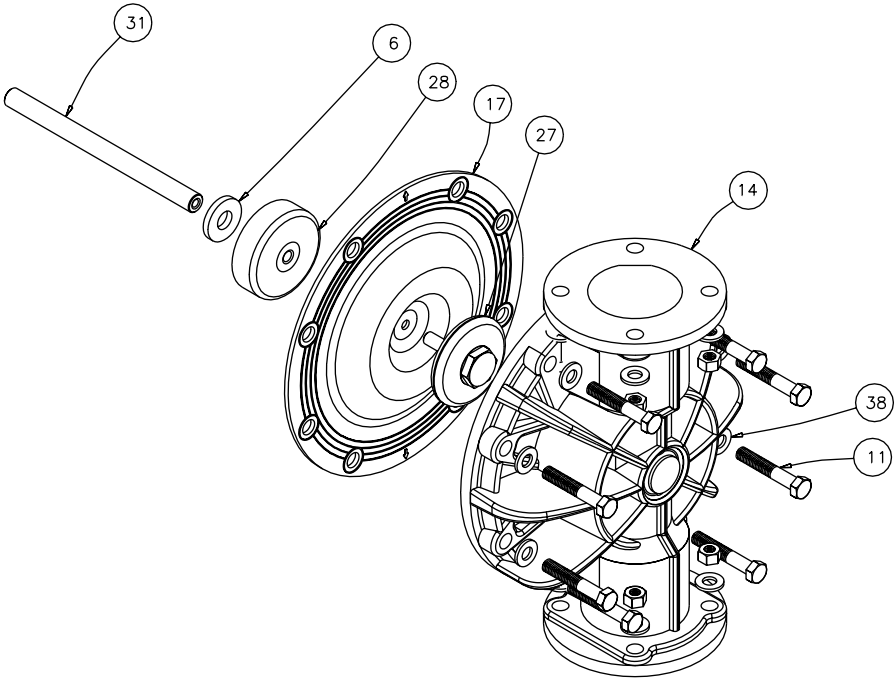

Diaphragm Service Drawing, with Overlay

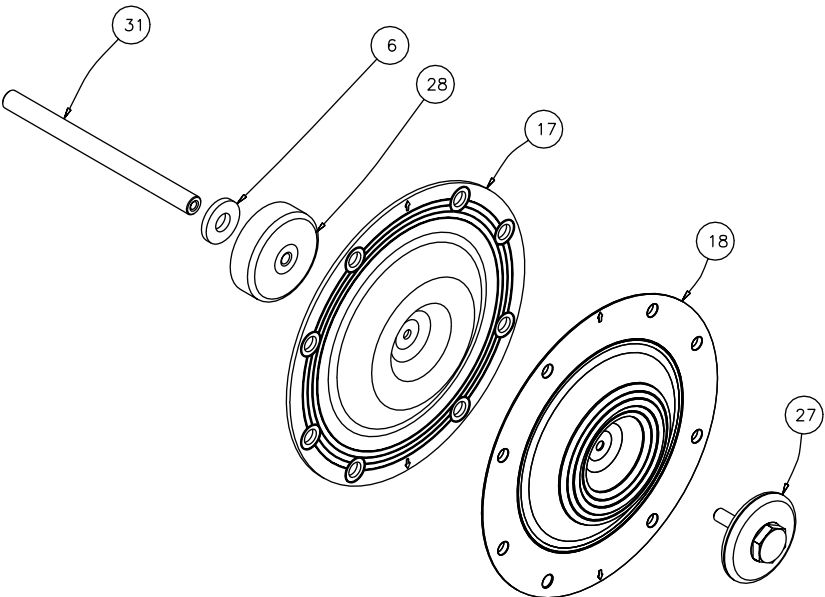

DIAPHRAGM SERVICING

To service the diaphragms first shut off the suction, then shut off the discharge lines to the pump. Shut off the compressed air supply, bleed the pressure from the pump, and disconnect the air supply line from the pump. Drain any remaining liquid from the pump.

Step #1: See the pump composite repair parts drawing, and the diaphragm servicing illustration.

Using a $\frac{9}{16}$ " wrench or socket, remove the 16 capscrews (items 10), hex nuts and washers that fasten the elbows (items 19) to the outer chambers (items 14). Remove the elbows with the manifolds and spacers attached.

Step #2: Removing the outer chambers.

Using a $\frac{9}{16}$ " wrench or socket, remove the 16 capscrews (items 11), hex nuts and washers that fasten the outer chambers, diaphragms, and inner chambers (items 15) together.

Step #3: Removing the diaphragm assemblies.

Use a $1\frac{3}{8}$ " (35mm) wrench or six pointed socket to remove the diaphragm assemblies (outer plate, diaphragm, and inner plate) from the diaphragm rod (item 31) by turning counterclockwise.

Insert a 1/4-20 capscrew or set screw into the smaller tapped hole in the inner diaphragm plate (item 28). Insert the protruding stud and the 1/4-20 fastener loosely into a vise. Use a $1\frac{3}{8}$ " wrench or socket to remove the outer diaphragm

plate (item 27) by turning counterclockwise. Inspect the diaphragm (item 17) for cuts, punctures, abrasive wear or chemical attack. Replace the diaphragms if necessary.

Step #4: Installing the diaphragms.

Push the threaded stud of the outer diaphragm plate through the center hole of the diaphragm. Thread the inner plate clockwise onto the stud. Use a torque wrench to tighten the diaphragm assembly together to 480 in Lbs. (54.23 Newton meters). Allow a minimum of 15 minutes to elapse after torquing, then re-torque the assembly to compensate for stress relaxation in the clamped assembly.

Step #5: Installing the diaphragm assemblies to the pump.

Make sure the bumper (item 6) is installed over the diaphragm rod.

Thread the stud of the one diaphragm assembly clockwise into the tapped hole at the end of the diaphragm rod (item 31) until the inner diaphragm plate is flush to the end of the rod. Insert rod into pump.

Align the bolt holes in the diaphragm with the bolt pattern in the inner chamber (item 15). Make sure the molded directional arrows on the diaphragm point vertically.

Fasten the outer chamber (item 14) to the pump, using the capscrews (items 11), hex nuts and flat washers.

On the opposite side of the pump, pull the diaphragm rod out as far as possible. Make sure the bumper (item 6) is installed over the diaphragm rod.

Thread the stud of the remaining diaphragm assembly clockwise into the tapped hole at the end of the diaphragm rod (item 31) as far as possible and still allow for alignment of the bolt holes in the diaphragm with the bolt pattern in the inner chamber. The molded directional arrows on the diaphragm must point vertically.

Fasten the remaining outer chamber (item 14) to the pump, using the capscrews (items 11), hex nuts and flat washers.

Step #6: Re-install the elbow/spacer/manifold assemblies to the pump, using the capscrews (items 10), hex nuts and flat washers.

The pump is now ready to be re-installed, connected and returned to operation.

OVERLAY DIAPHRAGM SERVICING

The PTFE overlay diaphragm (item 18) is designed to fit snugly over the exterior of the standard TPE diaphragm (item 17).

The molded directional arrows on the overlay diaphragm must point vertically.

Follow the same procedures described for the standard diaphragm for removal and installation.



IMPORTANT

Read these instructions completely, before installation and start-up. It is the responsibility of the purchaser to retain this manual for reference. Failure to comply with the recommendations stated in this manual will damage the pump, and void factory warranty.

PUMPING HAZARDOUS LIQUIDS

When a diaphragm fails, the pumped liquid or fumes enter the air end of the pump. Fumes are exhausted into the surrounding environment. When pumping hazardous or toxic materials, the exhaust air must be piped to an appropriate area for safe disposal. See illustration #1 at right.

This pump can be submerged if the pump materials of construction are compatible with the liquid being pumped. The air exhaust must be piped above the liquid level. See illustration #2 at right. Piping used for the air exhaust must not be smaller than 1" (2.54 cm) diameter. Reducing the pipe size will restrict air flow and reduce pump performance. When the pumped product source is at a higher level than the pump (flooded suction condition), pipe the exhaust higher than the product source to prevent siphoning spills. See illustration #3 at right.

CONVERTING THE PUMP FOR PIPING THE EXHAUST AIR

The following steps are necessary to convert the pump to pipe the exhaust air away from the pump.

Use a #8 Torx or flat screwdriver to remove the six self-tapping screws (item 1-L).

Remove the muffler cap and muffler (items 1-E and 1-G). The 1" NPT molded threads in the air distribution valve body (item 1-B).

Piping or hose may now be installed.

IMPORTANT INSTALLATION

NOTE: The manufacturer recommends installing a flexible hose or connection between the pump and any rigid plumbing. This reduces stresses on the molded plastic threads of the air exhaust port. Failure to do so may result in damage to the air distribution valve body.

Any piping or hose connected to the pump's air exhaust port must be physically supported. Failure to support these connections could also result in damage to the air distribution valve body.

Exhaust Conversion Drawing

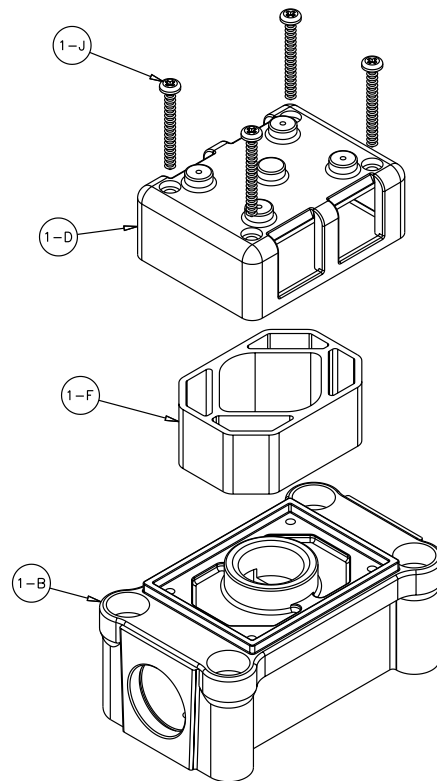

CONVERTED EXHAUST ILLUSTRATION

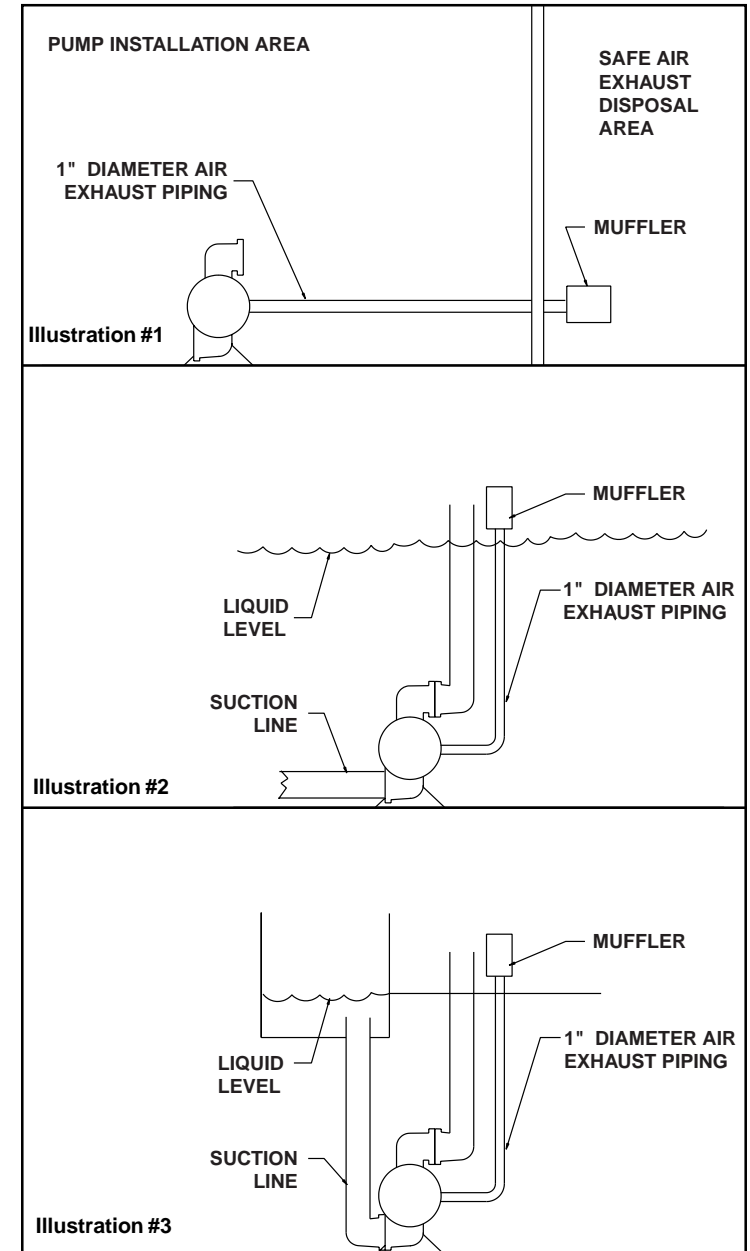

MODULAR CHECK VALVE SERVICING

Before servicing the check valves, first shut off the suction line and then the discharge line to the pump. Next, shut off the compressed air supply, bleed air pressure from the pump, and disconnect the air supply line from the pump. Drain any remaining fluid from the pump. The pump can now be removed for service.

To access the modular check valve, remove the elbows (items 19 from pump composite repair parts drawing). Use a $\frac{9}{16}$ " wrench or socket to remove the fasteners. Once the elbows are removed, the modular check valves can be seen in the cavities of the outer chamber (items 14).

Next remove the check valve seal (item 34). Inspect the seal for cuts or pinched areas. Replace seal as needed.

Disassemble the component parts of each modular check valve. Inspect the check valve retainer (item 30) for cuts, abrasive wear, or embedded materials. Replace as needed.

Inspect the check balls (items 3) for wear, abrasion, or cuts on the spherical surface. The check valve seats (items 36) should be inspected for cuts, abrasive wear, or embedded material on the surfaces of both the external and internal chamfers. The spherical surface of the check balls must seat flush to the surface of the inner chamfer on the check valve seats for the pump to operate to peak efficiency. Replace any worn or damaged parts as necessary.

Remove the remaining check valve seal (item 34). Inspect the seal for cuts or pinched areas. Replace seal as needed.

Re-assemble the modular check valve. The seat should fit snugly into the retainer.

Place a check valve seal (item 34) into the cavity of the outer chamber (item 14). Make sure the chamfer side of the seal faces out. Insert the modular check valve into the outer chamber with the retainer facing up. Install a check valve seal (item 34). Make sure the chamfer side of the seal faces the chamfer on the check valve seat or retainer.

The pump can now be reassembled, reconnected and returned to operation.

Modular Check Valve Drawing

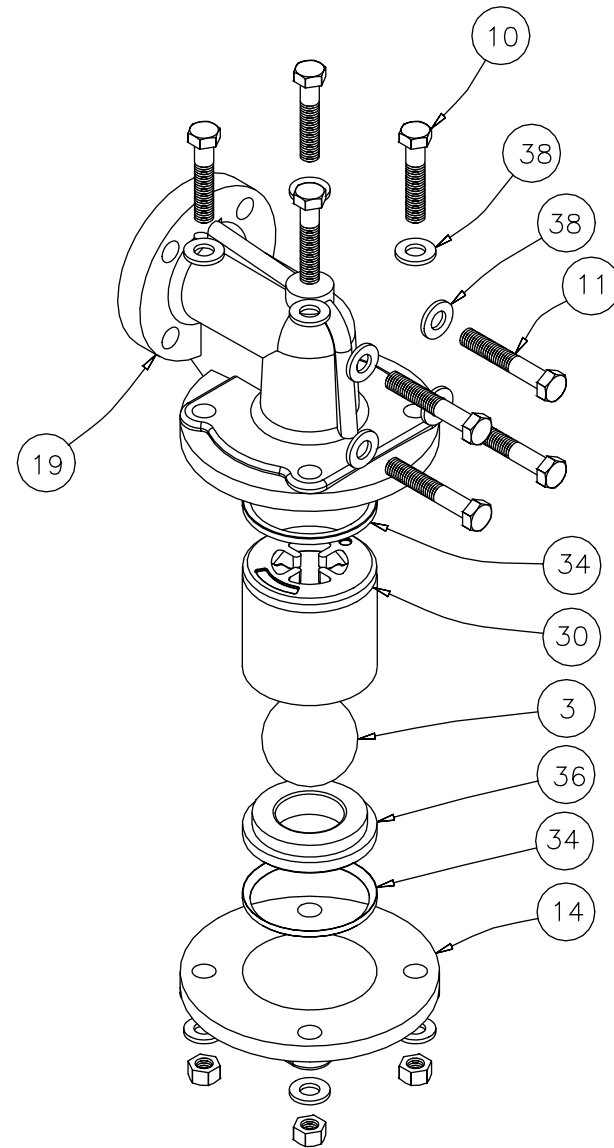

Dual Port Option Drawing

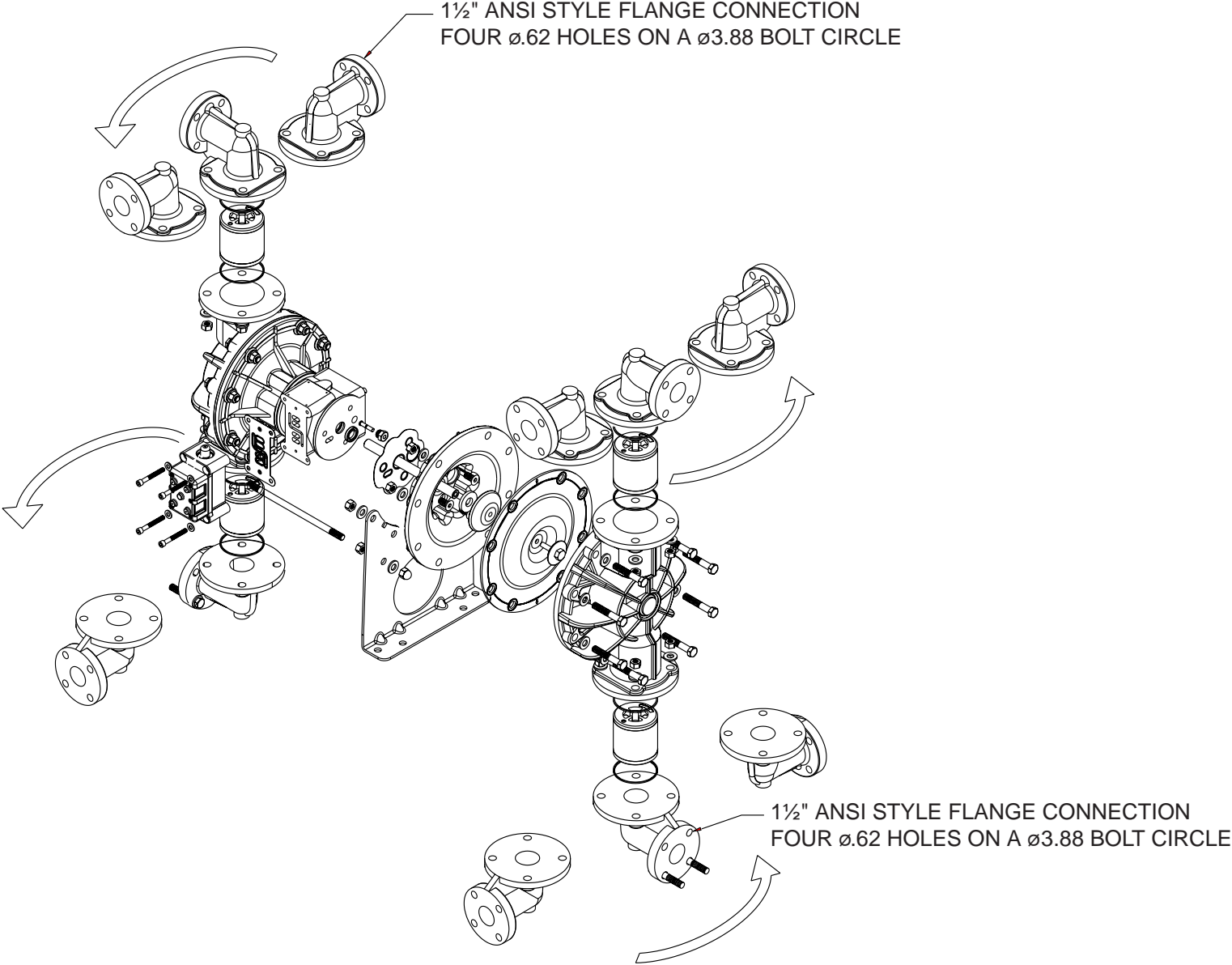

DUAL PORTING OPTIONS

Several dual porting options are possible. The pump can be converted to a dual port arrangement on both the suction and the discharge ends. The porting can be configured to a single suction and a dual discharge. The porting can be changed to a dual suction and a single discharge.

The above changes are possible because the porting flange of the elbows (items 19) are designed to mate with standard 125# ANSI style 4-bolt, 1½" pipe flanges.

Dual porting of both suction and discharge ends of the pump

Converting the pump from the standard single suction and discharge porting configuration to dual porting at each end is easy. Simply remove the manifold seals, spacers, and manifolds (items 35, 37, and 24 from pump assembly drawing) from the pump.

The discharge and suction elbows can be rotated at 90° increments (see arrows and optional positioning in the Dual Porting Drawing).

Single porting of the suction and dual porting of the pump discharge

To convert the pump from the standard single suction and single discharge porting configuration to a dual discharge porting arrangement remove the only the discharge manifolds, spacers, and manifold seals. Position the discharge elbows in the desired direction at 90° increments. (See arrows and optional positioning in the Dual Porting Drawing.)

Dual porting of the suction and single porting of the pump discharge

To convert the pump from the standard single suction and single discharge porting configuration to a dual suction porting arrangement remove the only the suction (bottom) manifolds, spacers, and manifold seals.

Position the suction elbows in the desired direction at 90° increments. (See arrows and optional positioning in the Dual Porting Drawing.)



! IMPORTANT

Read these instructions completely, before installation and start-up. It is the responsibility of the purchaser to retain this manual for reference. Failure to comply with the recommendations stated in this manual will damage the pump, and void factory warranty.

RuppTech® Leak Detection Options Drawing

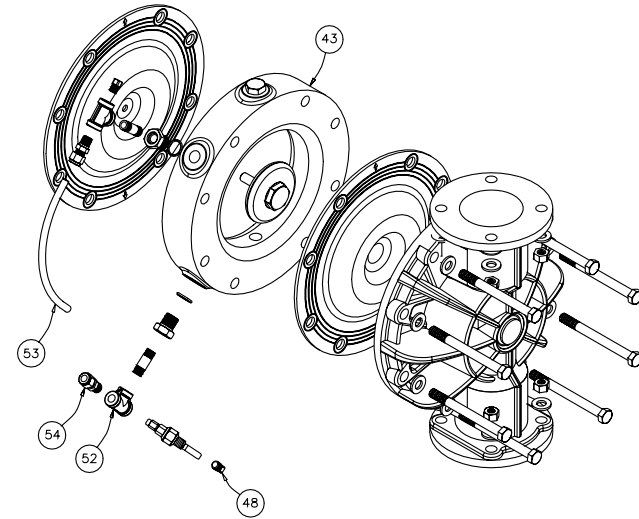
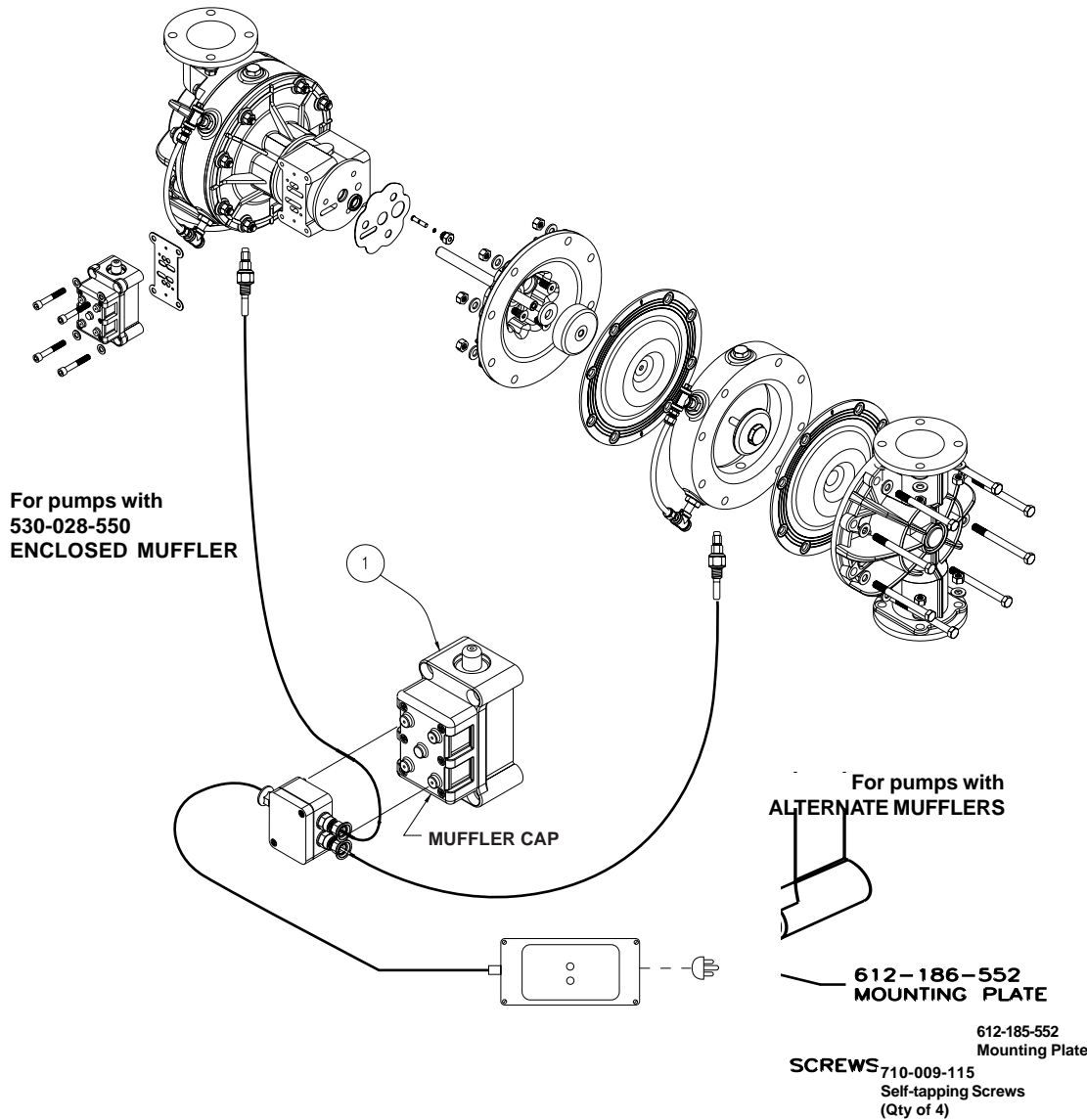

RuppTech® LEAK DETECTION OPTION A (ELECTRONIC)

Follow instructions found elsewhere in this manual, "Filling the RuppGUARD™ Spill Prevention Chambers" when installing leak detectors.

RuppTech® ELECTRONIC LEAK DETECTOR INSTALLATION

Kit 032-037-000	100VAC	50Hz
	or 110-120VAC	50/60Hz
	or 220-240VAC	50/60Hz

Kit 032-045-000 12-32VDC

To install electronic leak detectors, remove the bottom ¼" NPT pipe plug on the visual sight tube (item 53). Insert leak detector into the ¼" pipe tee (item 52).

RuppTech® LEAK DETECTION OPTION B (MECHANICAL)

Follow instructions found elsewhere in this manual, "Filling the RuppGUARD™ Spill Prevention Chambers" when installing leak detectors.

RuppTech® MECHANICAL LEAK DETECTOR INSTALLATION

Kit 031-023-110

To install mechanical leak detectors, remove the bottom ¼" NPT pipe plug on the visual sight tube (item 53). Insert leak detector into the ¼" pipe tee (item 52).

RuppTech® Pulse Output Kit Drawing

PULSE OUTPUT KIT OPTION

This pump can be fitted with a Pulse Output Kit. This converts the mechanical strokes of the pump to an electrical signal which interfaces with the RuppTech® Stroke Counter/ Batch Controller or user control devices such as a PLC.

The Pulse Output Kits mount directly onto the Muffler Cap on the Air Distribution Valve Assembly or onto the Air Distribution Valve Assembly when the threaded exhaust port or an auxiliary muffler is being used.

See the individual kits listed on the Pump Repair Parts List for further information.

Exhaust Port or Auxiliary Muffler Setup

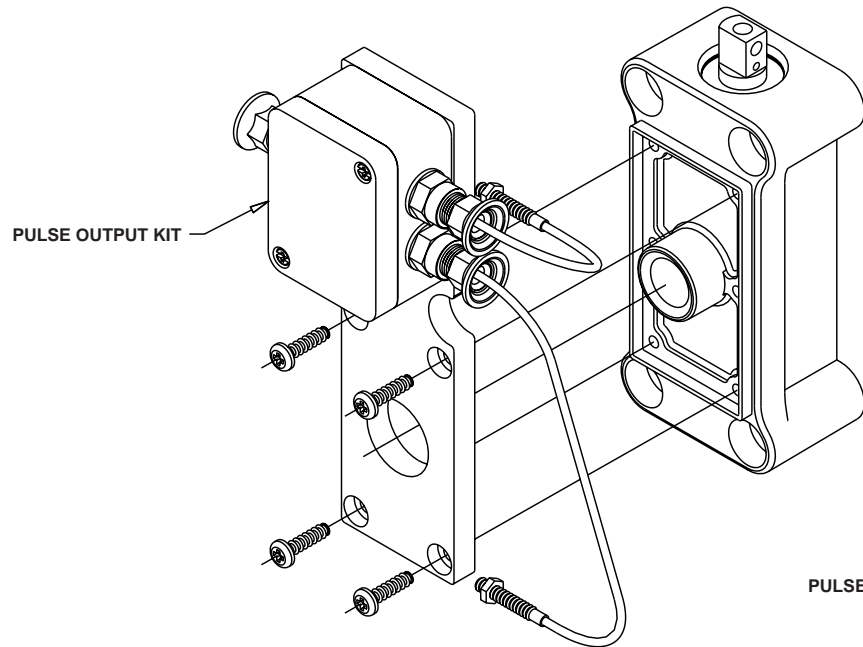

Integral Muffler Setup

