

SERVICE & OPERATING MANUAL



Hazardous Duty RS20 Metallic AirVantage Design Level 1

Table of Contents

SAFETY PRECAUTIONS

Engineering, Performance and Construction Data	1
Explanation of Pump Nomenclature	2
Performance Curve	3
Dimensions	4
Important Installation Information	5
Principle of Pump Operation	7
Principle of AirVantage	7
Installation and Start-Up	7
Air Supply	7
Air Line Moisture	7
Air Valve Lubrication	7
Air Inlet and Priming	7
Between Uses	7
Pump Troubleshooting	9
AirVantage Troubleshooting	10-11
Composite Repair Parts List	12
Composite Repair Parts Kits	13
Composite Repair Parts Drawing: Wetted Side	14
Diaphragm and Check Valve Servicing	15
Composite Repair Parts Drawing: Air Side	16

US Patent # 6,241,487
US Patent # 7,521,921 Pending

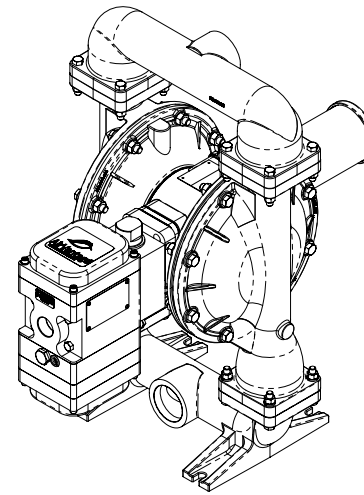

CE 0518

Ex II 2GD T4

Ex d ib IIB T4 Gb
Ex tb IIIC 135°C Db IP66
-20°C to +40°C
Sira 10ATEX1151X
IECEX SIR 10.0110X

SP 2350863
c US

Class I Div 1 - Groups C,D T4
Class II Div 1 - Groups F,G
Class I Zone 1, Ex d ib IIB T4
Class I Zone 1, AEx d ib IIB T4
Enclosure Type 4X
12 Volt (2 - 8) mA

Intermediate and AirVantage Sensor Servicing	17
Air Valve Servicing, Assembly Drawings and Parts List	18
Air Valve Servicing with Stroke Indicators, Assembly Drawings and Parts List	19
Pilot Valve and Actuator Plunger Servicing	20
Pulse Output Kits and Drawing	21
Composite Repair Parts Drawing - AirVantage Unit	23
AirVantage Servicing - Pilot Valve and Pressure Regulator	24
AirVantage Servicing - Power Generation Module	25
AirVantage Servicing - Control Module	26
AirVantage Servicing - Sensor Assembly	27
AirVantage Servicing - Poppet Valve Drawing	28
AirVantage Servicing - Poppet Valve	29
AirVantage Servicing - Check Valve	30
Grounding the Pump	31
Pumping Hazardous Liquids - Shutdown Procedure	32
Converting the Pump for Piping Exhaust Air	32
Material Codes for the Last 3 Digits of the Part Number	33
CE Declaration of Conformity - Machinery	34
CE Declaration of Conformity - ATEX	35
Declaration of Conformity - IECEx	36

Cautions - Read Operating and Safety Precautions First



! IMPORTANT

Before installation and start-up of the pump read these safety warnings and instructions in this manual completely. It is the responsibility of the purchaser to retain this manual for reference. Failure to comply with the recommendations stated in this manual will damage the pump, and void factory warranty.



! CAUTION

Before pump operation, inspect all gasketed fasteners for looseness caused by gasket creep. Re-torque loose fasteners to prevent leakage. Follow recommended torques stated in this manual.



! CAUTION

Pump not designed, tested or certified to be powered by compressed natural gas. Powering the pump with natural gas will void the warranty.



! WARNING

Before maintenance or repair, shut off the compressed air line, bleed the pressure, and disconnect the air line from the pump. The discharge line may be pressurized and must be bled of its pressure.



! WARNING

In the event of diaphragm rupture, pumped material may enter the air end of the pump, and be discharged into the atmosphere. If pumping a product which is hazardous or toxic, the air exhaust must be piped to an appropriate area for safe disposition.



! WARNING

Take action to prevent static sparking. Fire or explosion can result, especially when handling flammable liquids. The pump, piping, valves, containers or other miscellaneous equipment must be grounded. (See page 30)



! WARNING

This pump is pressurized internally with air during operation. Always make certain that all bolts are in good condition and that all of the correct bolts are reinstalled during assembly. Do not open when an explosive atmosphere may be present.



Users of electrical and electronic equipment (EEE) with the WEEE marking per Annex IV of the WEEE Directive must not dispose of end of life EEE as unsorted municipal waste, but use the collection framework available to them for the return, recycle, recovery of WEEE and minimize any potential effects of EEE on the environment and human health due to the presence of hazardous substances. The WEEE marking applies only to countries within the European Union (EU) and Norway. Appliances are labeled in accordance with European Directive 2002/96/EC. Contact your local waste recovery agency for a designated collection facility in your area.



None of the equipment supplied within the AirVantage unit either use or exceed the amounts stated above hazardous substances. A signed declaration from our supplier of the electronic/electrical portion of the AirVantage unit will be held on file stating their adherence to the RoHS, 2002/95/EC regulation.



The enclosure is non-conducting and may generate an ignition-capable level of electrostatic charges under certain extreme conditions. The user should ensure that the equipment is not installed in a location where it may be subjected to external conditions (such as high-pressure steam) which might cause a build-up of electrostatic charges on non-conducting surfaces. Additionally, cleaning of the equipment should be done only with a damp cloth."



! WARNING

When used for toxic or aggressive fluids, the pump should always be flushed clean prior to disassembly.



! WARNING

Before doing any maintenance on the pump, be certain all pressure is completely vented from the pump, suction, discharge, piping, and all other openings and connections. Be certain the air supply is locked out or made non-operational, so that it cannot be started while work is being done on the pump. Be certain that approved eye protection and protective clothing are worn at all times in the vicinity of the pump. Failure to follow these recommendations may result in serious injury or death.



! WARNING

Airborne particles and loud noise hazards. Wear ear and eye protection.



! WARNING

Use safe practices when lifting



! WARNING

Substitution of components may impair intrinsic safety.

Recycling

Warren Rupp is committed to protecting the environment and preventing pollution for the benefit of our employees, as well as local and global communities, now and in the future.

Many components of SANDPIPER® Metallic AODD pumps are made of recyclable materials (see chart on page 32 for material specifications). We encourage pump users to recycle worn out parts and pumps whenever possible. Follow all applicable guidelines if hazardous material has been pumped.

Special Conditions for Safe Use:

- For the safe operation of the equipment, it is necessary for the air supply line to be in a safe area
- The cable entry hole should be fitted with a suitably certified cable gland
- For the safe operation of the equipment, the pneumatic pump should be grounded
- The enclosure is non-conducting and may generate an ignition-capable level of electrostatic charges under certain extreme conditions. The user should ensure that the equipment is not installed in a location where it may be subjected to external conditions (such as high pressure steam) which might cause a build-up of electrostatic charge on the non-conducting surfaces. Additionally, cleaning of the equipment should be done only with a damp cloth.

**WARREN
RUPP, INC.**

Quality System
ISO 9001 Certified

Environmental
Management System
ISO 14001 Certified

IMEX
FLUID & METERING

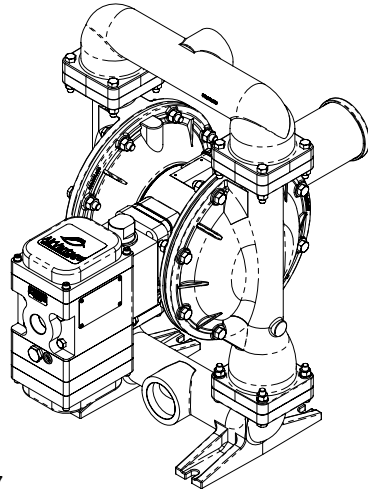

US Patent # 6,241,487
US Patent # 7,521,921 Pending

CE 0518

Ex II 2GD T4

Ex d ib IIB T4 Gb
Ex tb IIIC 135°C Db IP66
-20°C to +40°C
Sira 10ATEX1151X
IECEX SIR 10.0110X

SA 2350863
c US

Class I Div 1 - Groups C,D T4
Class II Div 1 - Groups F,G
Class I Zone 1, Ex d ib IIB T4
Class I Zone 1, AEx d ib IIB T4
Enclosure Type 4X
12 Volt (2 - 8) mA

SANDPIPER®

A WARREN RUPP, INC. BRAND

**Hazardous Duty
RS20 Metallic
AirVantage
Design Level 1
Ball Valve
Air-Operated Double Diaphragm Pump**

ENGINEERING, PERFORMANCE & CONSTRUCTION DATA

INTAKE/DISCHARGE PIPE SIZE	CAPACITY	AIR VALVE	SOLIDS-HANDLING	HEADS UP TO	DISPLACEMENT/STROKE
2" NPT (internal) 2" BSP Tapered (internal)	0 to 145 gallons per minute (0 to 548 liters per minute)	No-lube, no-stall design	Up to .25 in. (6mm)	125 psi or 289 ft. of water (125 psi or 8.6 bar inlet) (8.6 bar or 88 meters)	.42 Gallon / 1.59 liter
CAUTION! Operating temperature limitations are as follows:					
Materials					
				Operating Temperatures	
				Maximum	Minimum
Nitrile: General purpose, oil-resistant. Shows good solvent, oil, water and hydraulic fluid resistance. Should not be used with highly polar solvents like acetone and MEK, ozone, chlorinated hydrocarbons and nitro hydrocarbons.				190° F 88° C	-10° F -23° C
EPDM: Shows very good water and chemical resistance. Has poor resistance to oil and solvents, but is fair in ketones and alcohols.				280° F 138° C	-40° F -40° C
Neoprene: All purpose. Resistant to vegetable oil. Generally not affected by moderate chemicals, fats, greases and many oils and solvents. Generally attacked by strong oxidizing acids, ketones, esters, nitro hydrocarbons and chlorinated aromatic hydrocarbons.				200° F 93° C	-10° F -23° C
Santoprene®: Injection molded thermoplastic elastomer with no fabric layer. Long mechanical flex life. Excellent abrasion resistance.				275° F 135° C	-40° F -40° C
Virgin PTFE: Chemically inert, virtually impervious. Very few chemicals are known to react chemically with PTFE- molten alkali metals, turbulent liquid or gaseous fluorine and a few fluoro-chemicals such as chlorine trifluoride or oxygen difluoride which readily liberate free fluorine at elevated temperatures.				220° F 104° C	-35° F -37° C
FKM (Fluorocarbon): Shows good resistance to a wide range of oils and solvents; especially all aliphatic, aromatic and halogenated hydrocarbons, acids, animal and vegetable oils. Hot water or hot aqueous solutions (over 70°F) will attack FKM.				350° F 177° C	-40° F -40° C
Polypropylene:				180° F 82° C	32° F 0° C
UHMW Polyethylene:				180° F 82° C	32° F 0° C

For specific applications, always consult The Warren Rupp Chemical Resistance Chart

SANDPIPER® pumps are designed to be powered only by compressed air.

Explanation of Pump Nomenclature, Hazardous Duty RS20 Metallic · Design Level 1· Ball Valve

MODEL	Pump Brand	Pump Size	Check Valve Type	Design Level	Wetted Material	Diaphragm/ Check Valve Materials	Check Valve Seat	Non-Wetted Material Options	Porting Options	Pump Style	Pump Options	Kit Options	Shipping Weight lbs. (kg)
RS20B1ABBANASX0	RS	20	B	1	A	B	B	A	N	A	S	X0	91 (41)
RS20B1AEEANASX0	RS	20	B	1	A	E	E	A	N	A	S	X0	91 (41)
RS20B1AGTANASX0	RS	20	B	1	A	G	T	A	N	A	S	X0	91 (41)
RS20B1ANNANASX0	RS	20	B	1	A	N	N	A	N	A	S	X0	91 (41)
RS20B1A1EANASX0	RS	20	B	1	A	1	E	A	N	A	S	X0	91 (41)
RS20B1ACTANASX0	RS	20	B	1	A	C	T	A	N	A	S	X0	91 (41)
RS20B1IBBANASX0	RS	20	B	1	I	B	B	A	N	A	S	X0	157 (71)
RS20B1IEEANASX0	RS	20	B	1	I	E	E	A	N	A	S	X0	157 (71)
RS20B1IGTANASX0	RS	20	B	1	I	G	T	A	N	A	S	X0	157 (71)
RS20B1INNANASX0	RS	20	B	1	I	N	N	A	N	A	S	X0	157 (71)
RS20B1I1EANASX0	RS	20	B	1	I	1	E	A	N	A	S	X0	157 (71)
RS20B1ICTANASX0	RS	20	B	1	I	C	T	A	N	A	S	X0	157 (71)
RS20B1SBBANASX0	RS	20	B	1	S	B	B	A	N	A	S	X0	142 (64)
RS20B1SEEANASX0	RS	20	B	1	S	E	E	A	N	A	S	X0	142 (64)
RS20B1SGTANASX0	RS	20	B	1	S	G	T	A	N	A	S	X0	142 (64)
RS20B1SNNANASX0	RS	20	B	1	S	N	N	A	N	A	S	X0	142 (64)
RS20B1S1EANASX0	RS	20	B	1	S	1	E	A	N	A	S	X0	142 (64)
RS20B1SCTANASX0	RS	20	B	1	S	C	T	A	N	A	S	X0	142 (64)

Note: Models listed in the table are for reference only. See nomenclature below for other models.

Pump Brand

RS= SANDPIPER®
AirVantage

Pump Size

20= 2"

Check Valve Type

B = Ball

Design Level

1 = Design Level

Wetted Material

A = Aluminum
I = Cast Iron
S = Stainless Steel
H = Alloy C

Diaphragm Check Valve Materials

1 = Santoprene/Santoprene
2 = PTFE-Santoprene/PTFE
B = Nitrile/Nitrile
C = FKM/PTFE
E = EPDM/EPDM
I = EPDM/Santoprene
G = PTFE-Neoprene/PTFE
N = Neoprene/Neoprene

Check Valve Seat

A = Aluminum
B = Nitrile
C = Carbon Steel
E = EPDM
N = Neoprene
S = Stainless Steel
T = PTFE
V = FKM

Non-Wetted Material Options

A = Painted Aluminum
J = Painted Aluminum w/PTFE Coated Hardware
Y = Painted Aluminum with Stainless Steel Hardware

Porting Options

N = NPT Threads
B = BSP (Tapered) Threads
R = Raised Face 150# Threaded ANSI Flange

Pump Style

A = Anodized Aluminum Air Saving Valve

Pump Options

S = Self-Contained Electrical Generation with High Flow Metal Muffler

Kit Options

X0= EST ATEX Compliant
X1= ATEX, Intrinsically-Safe 5-30VDC, 110/120VAC, 220/240VAC Pulse Output Kit
Y0= EST US Hazardous Duty
Y1= US Hazardous Duty, Intrinsically-Safe 5-30VDC, 110/120VAC, 220/240VAC Pulse Output Kit

Performance Curve, Hazardous Duty RS20 Metallic Design Level 1

Performance based on the following: elastomer fitted pump, flooded suction, water at ambient conditions.
 The use of other materials and varying hydraulic conditions may result in deviations in excess of 5%.

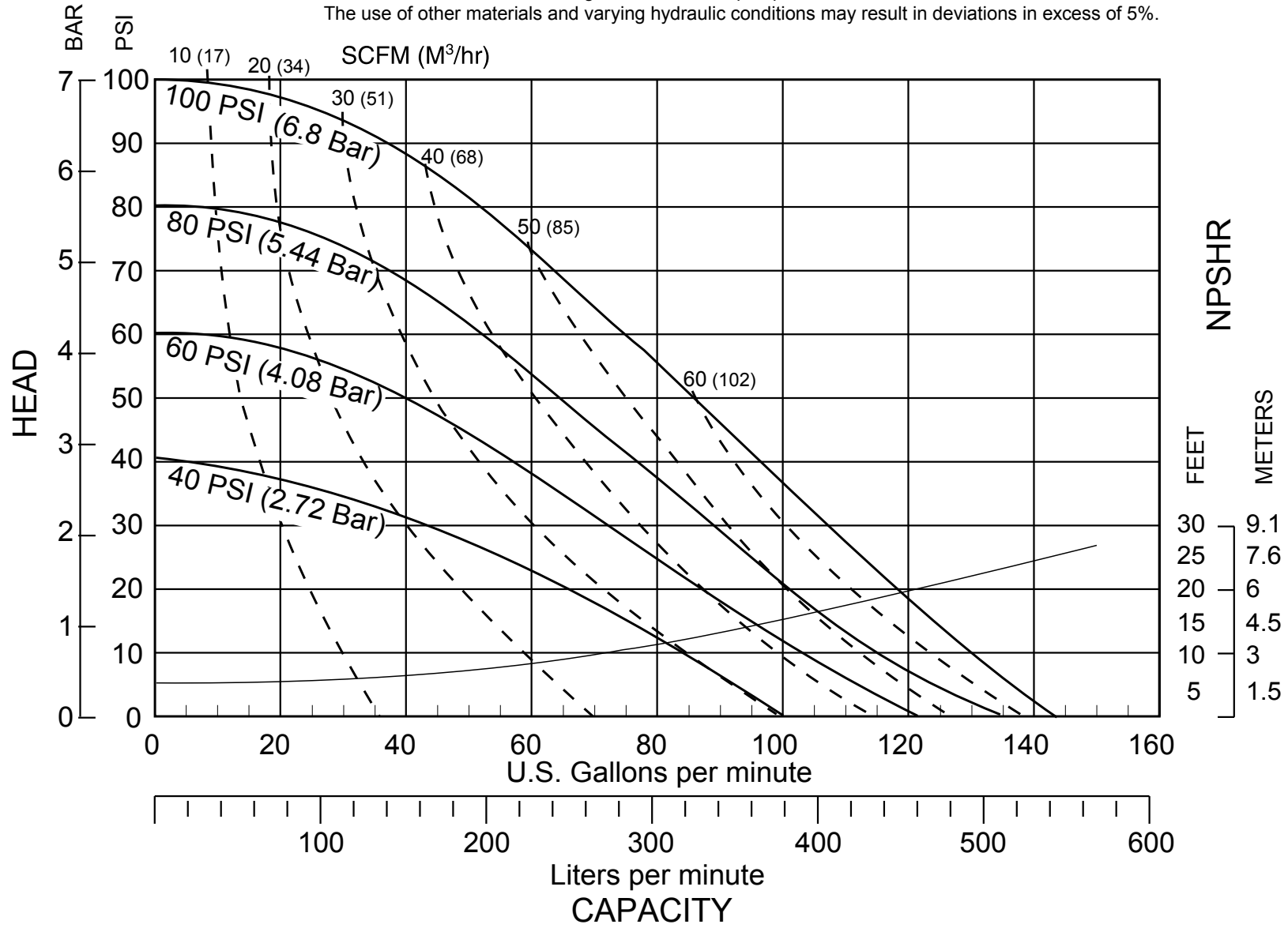

Dimensions: Hazardous Duty RS20 Metallic

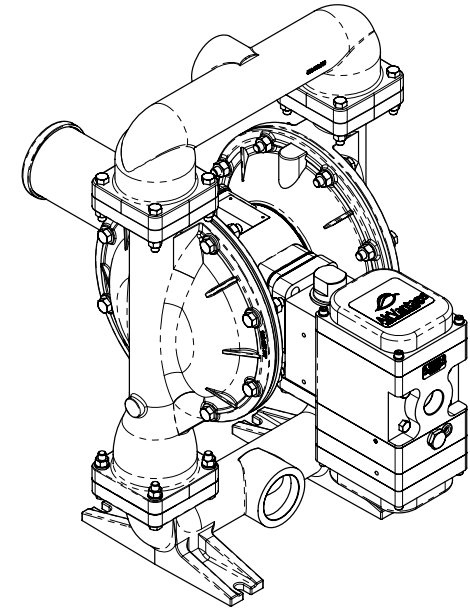
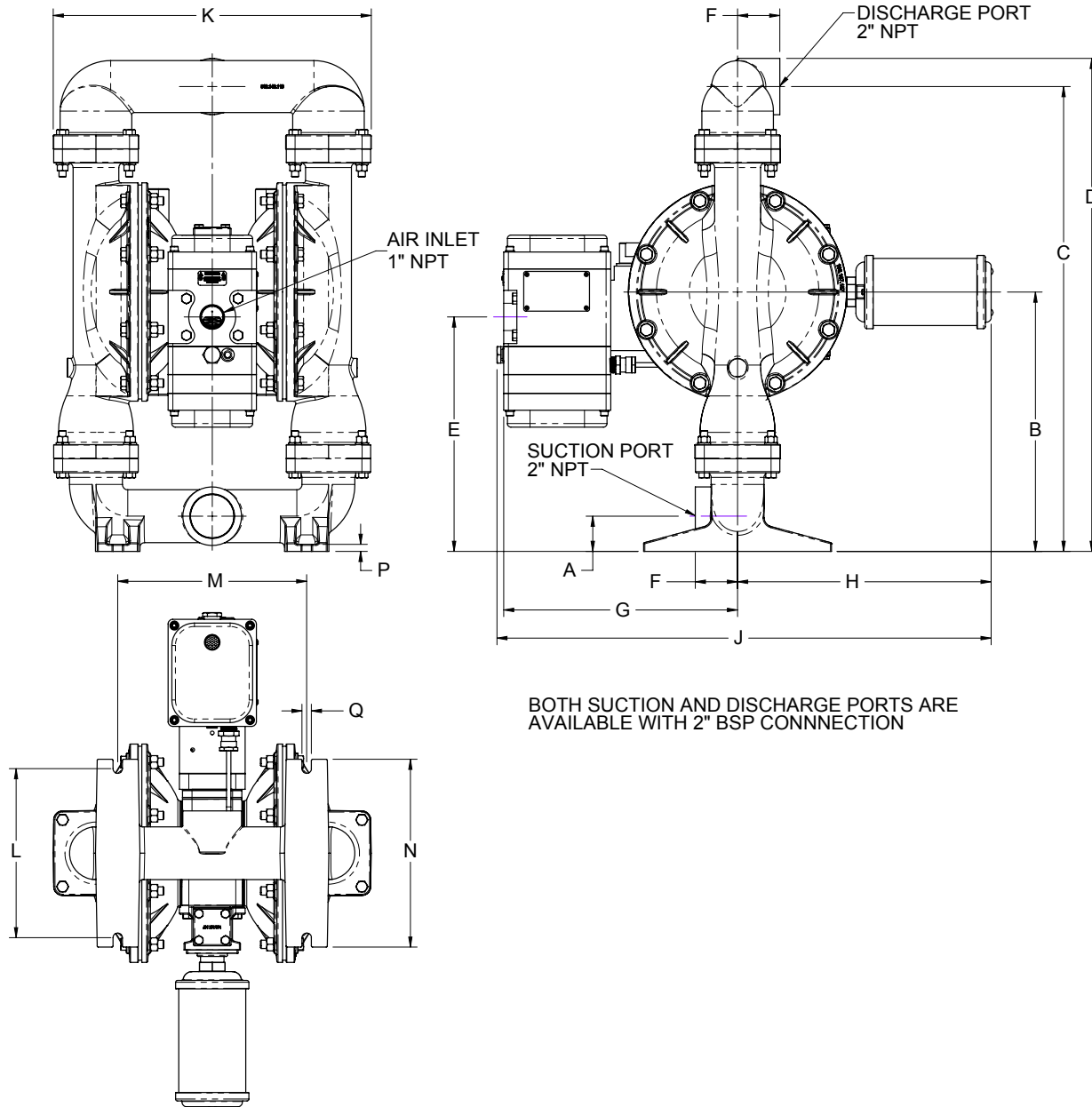

BOTH SUCTION AND DISCHARGE PORTS ARE AVAILABLE WITH 2" BSP CONNECTION

	English ±.125		Metric ±3mm	
	Aluminum Cast Iron	Stainless Alloy "C"	Aluminum Cast Iron	Stainless Alloy "C"
A	1.88	2.00	48	51
B	13.81	13.94	351	354
C	24.75	24.88	629	632
D	26.25	26.38	667	681
E	12.50	26.62	317	321
F	2.25		57	
G	12.46		316	
H	13.50		343	
J	26.31		668	
K	16.94		430	
L	9.00		229	
M	10.06		256	
N	10.00		254	
P	.38		10	
Q	.50		13	

Important Installation Information

Use of the standard AODD Installation Guide is recommended for pumps fitted with AirVantage technology. Install shut-off valves on both the suction and discharge of the pump. (This will help limit the amount of product that enters the center section of the pump in the event of a diaphragm failure.) Using shut-off valves in conjunction with a drain port also provides a means of allowing the lines to be drained when maintenance needs to be conducted.

When the supply liquid level is above the air inlet of the pump, and a diaphragm fails, the pumped liquid or fumes can enter the air end through the point of failure. When a diaphragm failure is detected, it is best to close the shut-off valves and bleed the lines of product. This will limit the ability of the material being pumped to enter the AirVantage. Failure to do so may result in damage to the AirVantage and air distribution components.

If a diaphragm failure has been detected in pumps fitted with AirVantage, the following procedure for shut-down must be used:

1. Close the suction shut-off valve (this will limit any new product from entering the pump)
2. Close the discharge shut-off valve (this will stop any product from reentering the pump)
3. Close the air supply shut-off valve
4. Drain the discharge line
5. Drain the suction line
6. Perform maintenance

Caution: When performing a direct spray washdown, the AirVantage exhaust outlet should be covered with protective tape. Failure to do so may damage internal components. (See page 23)



WARNING

In the event of diaphragm rupture, pumped material may enter the air end of the pump, and be discharged into the atmosphere. If pumping a product which is hazardous or toxic, the air exhaust must be piped to an appropriate area for safe disposition.

Suggested Installation Guide

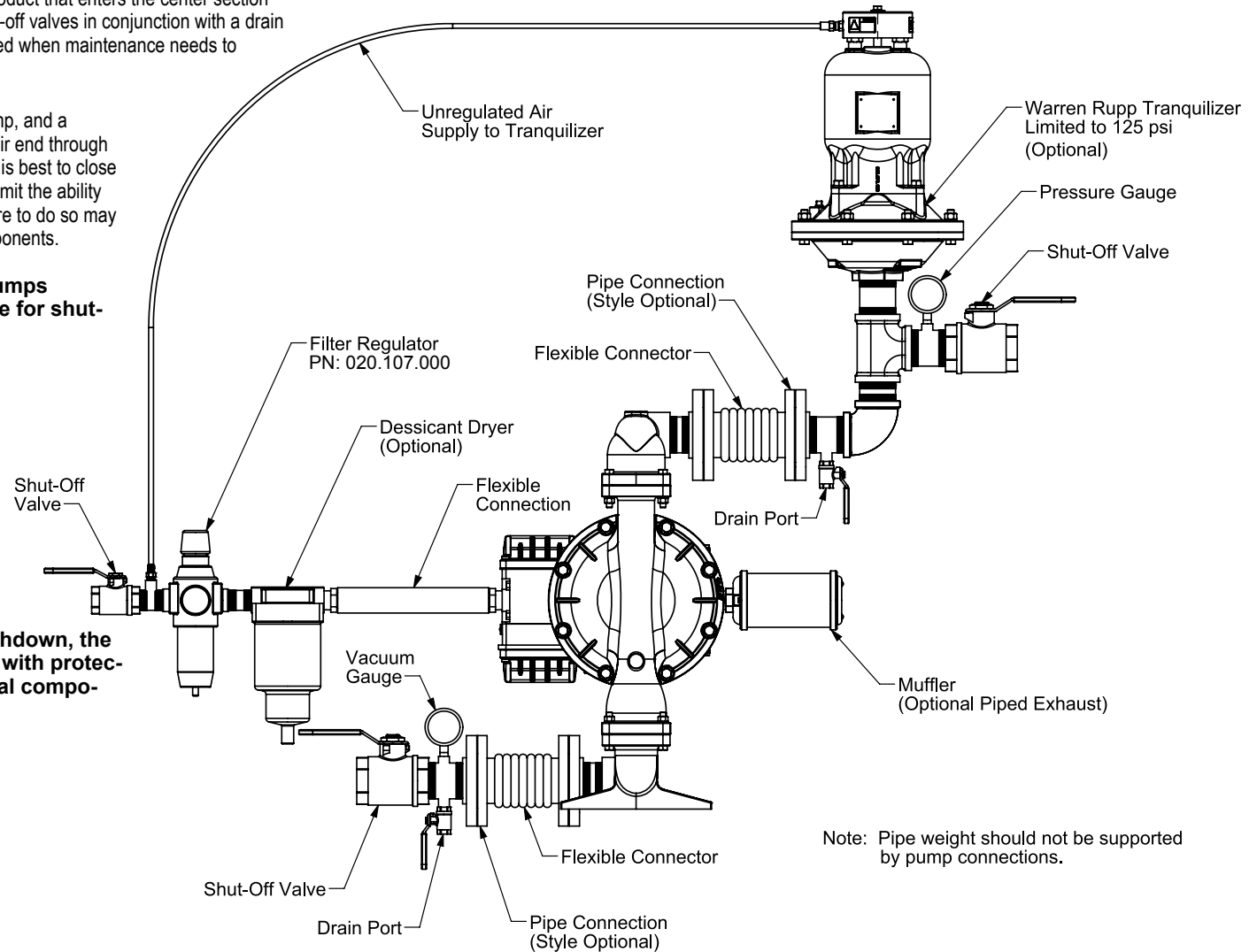

Note: Pipe weight should not be supported by pump connections.

This Page Intentionally Blank

PRINCIPLE OF PUMP OPERATION

This ball valve fitted pump has been equipped with IDEX's patented AirVantage equipment. To fully understand the operation of the AirVantage, one must first understand the basics of Air Operated Double Diaphragm (AODD) pumps. AODD's are powered by compressed air. The compressed air is directed behind each of the flexible diaphragms by a Main Air Valve. Once the diaphragm has reached the end of its stroke, a Pilot Valve is mechanically actuated, sending an air signal back to the Main Air Valve which redirects air to the opposite diaphragm. This causes the diaphragm assemblies, which are connected by a common Diaphragm Rod, to move in a reciprocating action.

Air is directed to the inboard side of the diaphragm, which is closest to the center of the pump. This is referred to as the air side of the diaphragm. The opposite side is commonly called the fluid side. Most AODD pumps have a 1:1 ratio design. This means, when the discharge of the pump is closed completely (dead headed), the maximum pressure the pump will create will be equal to the air pressure being applied to the pump. At this point, and only at this point, the diaphragm will be completely balanced. The air pressure is equivalent to the fluid pressure and there will be no movement of the diaphragm. If the pump is stroking, then the system is not balanced. There will be more pressure applied to the air side than fluid pressure on the fluid side.

During each stroke of the pump there are two distinct operations that happen. One diaphragm is moving away from the center of the pump, moving fluid out of the Discharge Manifold, while the other diaphragm is moving toward the center, bringing fluid into the Suction Manifold. Considering that the pump has a common suction and discharge port, these two operations are separated from each other through a series of Check Valves.

PRINCIPLE OF AIRVANTAGE

AirVantage is a special air side device which uses equipment that can accurately monitor the operation of the pump. Based on the monitored information, meter the correct amount of air needed to perform the work required, and NOTHING MORE.

Once the pump starts up and the AirVantage is turned on. The LED indicator light will go through a series of patterns. Initially the light will be solid green. This indicates the AirVantage is allowing the pump to reach a steady state. Next, the light will pulse at a very rapid rate. This is called the learn phase. Learn is where the AirVantage monitors the pump in non-AirVantage mode. This will set the parameters for operation in AirVantage mode. In less than one minute, the pump will change tones. The LED indicator light will start an uneven blink when optimization has started. Optimization will be completed once the LED light is blinking in unison with the stroke rate of the pump. All this is completed without sacrificing a significant amount of flow.

INSTALLATION AND START-UP

The pump should be located near the product being pumped, keeping the suction line as short as possible. Keep the number of fittings between the product and the pump to a minimum and maintain the line size, if possible. Better results will always be realized if the line size of the suction line is increased by one size. It's not recommended to hook up rigid pipe directly to the pump. Some method of expansion joint or vibration isolator should be used. A Warren Rupp Tranquilizer® is recommended to reduce the pulsation in the flow. If the fluid level is more than 10 feet (3 meters) above the level of the pump, a pressure regulating device may need to be added to the exhaust of the pump (Consult the factory for recommendations).

AIR SUPPLY

The air supply pressure cannot exceed 125 psi (8.6 bar). The air line and associated components (filters, regulators, solenoids valves, etc.) should not be less than ½" (13 mm). Though, ¾" (19mm) or greater is preferred. An air line filter-regulator is necessary for the AirVantage installation. The required component (PN: 020.107.000) is available through the distributor. Rigid pipe should not be hooked directly to the air inlet of the AirVantage. A flexible hose should be installed to reduce the strain. Do not let the weight of the air line components be supported by the air inlet of the pump. Failure to provide a means of supporting the weight may result in damage to the pump. If the pump is going to be shut down for any extended length of time it is recommended that the air supply to the pump should be shut off.

SPECIAL CONDITIONS FOR SAFE USE

For the safe operation of the equipment, it is necessary for the air supply to come from a safe area, therefore, the supplied air shall be clean.

AIR LINE MOISTURE

Water in the compressed air supply can create problems such as icing and freezing of the exhaust air. The formation of ice in the exhaust can cause the pump to cycle erratically, degrade efficiency, or even stop the pump. Fitting the pump with the AirVantage technology reduces the exhaust temperature. This is due to more energy being extracted from every pulse of air. When more energy is extracted, the temperature of the air is reduced. Some method of air drying will be necessary. Most refrigerant dryers installed on compressors can reduce the dewpoint to about 40° F. This is normally adequate for most pumping applications. If further drying needs to occur due to internal ice build-up, a desiccant dryer can be installed. These air line dryers can lower the dewpoint to around -40° F.

AIR VALVE LUBRICATION

The air valve and pilot valve are designed to operate without lubrication. There may be instances of personal preference or when extremely dry air is being used (instrument quality or nitrogen) that a small amount of lubrication will improve the life of the rubber components being used on the air side of the pump. The lubrication may be added using an air line lubricator (¾" PN: 020.051.001 – 1" PN: 020.052.001). At the point of operation use SAE 10 weight, non detergent oil at a maximum rate of 1 drop per hour for every 20 scfm (9.4 liters/sec) of air consumption. Consult the pump curve to determine this value. The smallest amount needed is preferred.

AIR INLET AND PRIMING

To start the pump, make sure the AirVantage switch is in the off position. Increase the pressure until the pump starts to cycle. The pump stroke rate should slow slightly when the pump is primed. Once the pump is fully primed, increase the pressure at the regulator until the desired flow rate is achieved. Again, the pump curve can be used to derive this value. If increasing the pressure to the pump does not generate a higher flow rate, then cavitation has occurred. Back the regulator off slightly. To gain the most efficiency from the pump, try to run the pump fully primed at all times.

BETWEEN USES

When the pump is being used to move materials that tend to settle out or solidify, the pump should be flushed to prevent damage. The product that remains in the pump could dry and settle out. This could potentially cause damage to the diaphragms and/or check valves during restart. In freezing temperatures the pump must be completely drained between uses. Due to the addition of the new technology, it is recommended the air supply to the pump be shut off if the pump is going to be shut down for an extended length of time.



WARNING

Hazardous Duty Rating

This pump is certified to be operated in the hazardous areas listed on the front cover. To maintain this certification, only genuine, approved parts must be used and assembled in accordance to the instructions detailed in this manual by a competent person. Any deviation or modification to this will invalidate certification and may result in serious injury or death.

This Page Intentionally Blank

PUMP TROUBLESHOOTING

⚠ CAUTION! WHENEVER TROUBLESHOOTING OR PERFORMING ANY REPAIRS ON ANY WARREN RUPP EQUIPMENT, ALWAYS REMOVE THE AIR SUPPLY LINE TO THE PUMP AND WEAR PROPER PERSONAL PROTECTIVE EQUIPMENT.

PUMP WILL NOT CYCLE

What to Check: • The system head exceeds the air supply pressure to the pump.

Corrective Action: • Increase the air inlet pressure to the pump. Most diaphragm pumps are designed for 1:1 pressure at zero flow.

What to Check: • Check ESADS+, including pilot valve assembly and main air valve assembly.

Corrective Action: • Disassemble and inspect the main air distribution valve, pilot valve, and pilot valve actuator pins. Check for scores, wear, or damaged o-rings. Replace parts as necessary. Refer to the exploded view drawing and air valve section (P.18 & 20).

What to Check: • Blocked discharge line.

Corrective Action: • Check for obstruction or closed discharge line.

What to Check: • Blocked pumping chamber.

Corrective Action: • Disassemble and inspect wetted chambers of the pump. Remove or flush any obstructions. Refer to page 14 for disassembly.

PUMP CYCLES, BUT WILL NOT FLOW OR FLOW RATE IS UNSATISFACTORY

What to Check: • Restricted or undersized air line.

Corrective Action: • Make sure there are no obstructions or restrictions in the air inlet to the pump. Install proper size air line and/or air line equipment. Refer to air supply section (p.7) air inlet plumbing recommendations.

What to Check: • Restricted or undersized suction piping.

Corrective Action: • Make sure there are no obstructions or restrictions in the suction line or related suction components such as screens or strainers. Install the proper size suction line and/or equipment. It is recommended that any suction line components and pipe size be at least the same size as the suction line thread size to the pump. Though best results will always be realized if the line size of the suction line is increased by one size. Refer to the installation section (p.5) for recommended suction plumbing recommendations.

What to Check: • Blocked air exhaust muffler.

Corrective Action: • Remove muffler, clean or de-ice and reinstall.

What to Check: • Excessive Suction Lift.

Corrective Action: • For lifts exceeding 20 feet (6 meters), filling the pump chambers with liquid will prime the pump in most cases. If not, place pump closer to fluid level.

What to Check: • Suction line cavitation.

Corrective Action: • If no obstructions are in the suction line of the pump, decrease the inlet air pressure and/or volume to the pump. This will slow down the diaphragm speed and reduce the cavitation.

What to Check: • Partially blocked exhaust muffler.

Corrective Action: • Remove muffler and make sure that some of the material being pumped has not migrated into the muffler element. If it has, replace the element or clean it and reinstall. If product has made it to the muffler, then the diaphragm assembly will need to be inspected. Refer to the Diaphragm Replacement section (p.15).

What to Check: • Suction side air leakage or air in the product.

Corrective Action: • Visually inspect all suction side gaskets, seals, as well as pipe and pipe connections.

PUMP CYCLE SEEMS UNBALANCED OR PRODUCES EXCESSIVE VIBRATION

What to Check: • Excessive flooded suction in system.

Corrective Action: • Check height of fluid above pump. For flooded conditions, exceeding 10 feet (3 meters) of liquid, install a back pressure device in the exhaust side of the pump.

What to Check: • Worn or misaligned check valve or check valve seat.

Corrective Action: • Disassemble the wet end of the pump and inspect check valves and seats for wear and proper seating. Replace them if necessary. Refer to the Check Valve section (p.15) for disassembly instructions.

What to Check: • Obstructed check valves.

Corrective Action: • Disassemble the wet end of the pump and look for obstructions that may prevent the check valve from seating on the seat. Look for damage on the valve and the seat. Replace them as necessary. Refer to the Check Valve section for disassembly (p.15).

What to Check: • Rigid pipe connections.

Corrective Action: • Install flexible pipe isolators or expansion joints between the plumbing and the pump.

What to Check: • Pulsation in the discharge line.

Corrective Action: • Excessive pulsation in the discharge line may be corrected by installing a Warren Rupp Tranquilizer Surge Suppressor.

AirVantage Troubleshooting

⚠ Caution! Whenever troubleshooting or performing any repairs on any Warren Rupp equipment, always remove air supply line to the pump and wear proper personal protective equipment.

LED OUTPUT FOR AirVantage UNIT

STATE	LED OUTPUT
Startup/Settle/Deadhead	Solid
Standby/Low Flow	1 Second ON / 1 Second OFF
Learn Mode	0.1 Seconds ON / 0.1 Seconds OFF
Seek/Optimize	1 Second ON / 0.1 Seconds OFF
Steady State/Air Savings	OFF / ON in rhythm with Cycle Rate of Pump

AirVantage LED DOES NOT LIGHT UP AT ALL

What to Check:

- Make sure power switch on the control module is turned on, (depressed to the left)
- Make sure air is being supplied to pump

Corrective Action:

- Cycle power switch off/on in a safe area
- Unplug patch cable and cycle power switch off/on in a safe area
- Consult Factory After Sales Support team

AirVantage LED LIGHTS UP AND STAYS ON SOLID

What to Check:

- Make sure patch cable is plugged in and locked

Corrective Action:

- Consult Factory After Sales Support team

VALVE FIRES ONCE AND IMMEDIATELY RESETS

Corrective Action:

- Consult Factory After Sales Support team

VALVE LED NEVER LEAVES SEEK MODE - AirVantage LED PULSING IN TIME TO PUMP, BUT VALVE NOT ACTUATING AND THE PUMP IS NOT SAVING AIR

Corrective Action:

- Consult Factory After Sales Support team

UNEXPECTED OPERATING CONDITION (AIR SAVINGS OR FLOW RATE)

What to Check:

- Check for varying environmental pumping conditions (changing head or suction)
- Check ice buildup in exhaust area
- Inspect sleeve and spool set for damage

Corrective Action:

- Consult Factory After Sales Support team

PUMP CYCLING IS UNSTABLE OR ERRATIC

What to Check:

- Run pump without AirVantage and check pump operation (turn off AirVantage in a safe area)
- Make sure pump has correct sleeve and spool set installed
- Make sure patch cable plug is connected and locked
- Make sure power wire connectors are tight

Corrective Action:

- Consult Factory After Sales Support team

PUMP RUNNING SLOWLY

What to Check:

- Run pump without AirVantage and check operation (turn off AirVantage in a safe area)
- Cycle the power off/on to the control module to reset controller (turn off AirVantage in a safe area)
- Check ice buildup in exhaust area
- Inspect sleeve and spool set for damage

Corrective Action:

- Consult Factory After Sales Support team
- Cycle the power switch on the control module off/on (turn off AirVantage in a safe area)



AirVantage Troubleshooting Continued

AirVantage RESETS AND ENTERS LEARN MODE TOO FREQUENTLY

What to Check:

- Check for excessive varying environmental pumping conditions (changing head or suction)
- Check ice buildup in exhaust area
- Inspect sleeve and spool set for damage
- Make sure patch cable plug is connected and locked

Corrective Action:

- Consult Factory After Sales Support Team

PUMP STALLS, RESETS, LEARNS, SEEKS AND REPEATS

What to Check:

- Make sure patch cable plug is connected and locked
- Check ice buildup in exhaust area

Corrective Action:

- Consult Factory After Sales Support Team

PUMP MOVES OUT OF STEADY STATE AND NEVER ATTEMPTS TO RELEARN (LED ON)

What to Check:

- Make sure patch cable plug is connected and locked
- Cycle the power off/on to the control module

Corrective Action:

- Consult Factory After Sales Support Team
- Cycle the power switch on the control module off/on

WHAT TO DO IN THE EVENT OF A DIAPHRAGM FAILURE

If a diaphragm failure has been detected in pumps fitted with AirVantage, see page 5 for shut-down procedure.

What to Check:

- Has product migrated to the sensor?

Corrective Action:

- If the sensor has been submerged in product, the sensor will need to be replaced. Consult the AirVantage servicing section of the manual for detailed instructions.

What to Check:

- Has product contaminated the check valve cartridge?

Correct Action:

- If a significant amount of product has made it into the check valve assembly, then the unit will need to be disassembled for inspection. If the check valve assembly is damaged, then it will need to be replaced. Consult parts list for information.

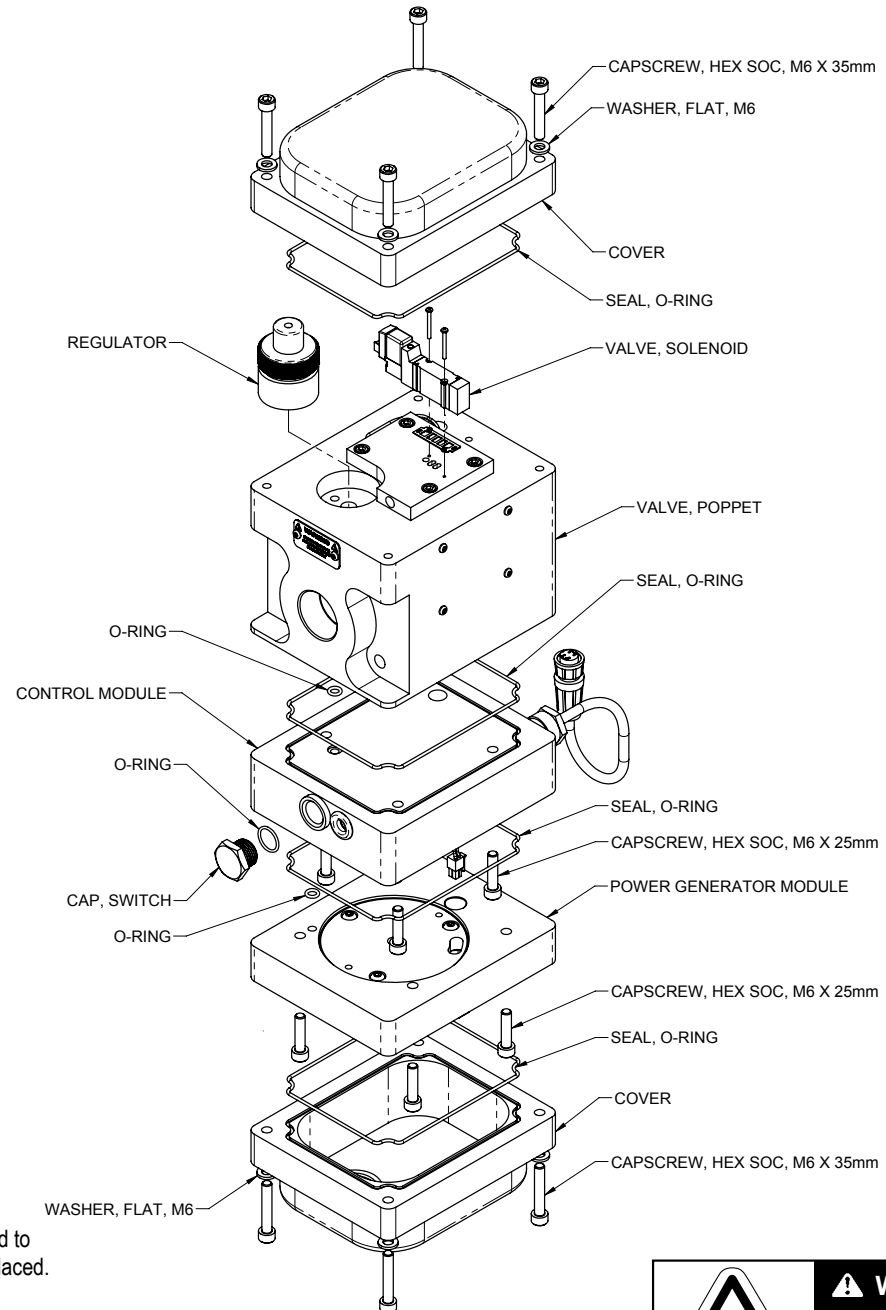

Composite Repair Parts List

Item	Part Number	Description	Qty	Item	Part Number	Description	Qty
1	031-183-003	Assy - Air Valve (See Exploded View for Details)	1	26	518-146-010	Manifold, Discharge (Cast Iron Units)	1
2	032-054-000	Assy - AirVantage (See Exploded View for Details)	1		518-146-010E	Manifold, Discharge (Cast Iron Units)	1
3	050-017-354	Check Ball, Santoprene	4		518-146-110	Manifold, Discharge (Stainless Units)	1
	050-017-360	Check Ball, Nitrile	4		518-146-110E	Manifold, Discharge (Stainless Units)	1
	050-017-364	Check Ball, EPDM	4		518-146-112	Manifold, Discharge (Alloy-C Units)	1
	050-017-365	Check Ball, Neoprene	4		518-146-112E	Manifold, Discharge (Alloy-C Units)	1
	050-018-600	Check Ball, PTFE	4		518-146-156	Manifold, Discharge (Aluminum Units)	1
4	070-006-170	Bushing, Intermediate	2		518-146-156E	Manifold, Discharge (Aluminum Units)	1
5	095-110-000	Assy, Pilot Valve (See Exploded View for Details)	1	27	530-038-000	Muffler	1
6	114-029-157	Assy, Intermediate (See Exploded View for Details)	1	28	545-005-115	Nut, Hex (3/8-16 Stainless)	16
7	132-035-360	Bumper, Diaphragm	2		545-005-330	Nut, Hex (3/8-16 Zinc Plated Steel)	16
8	135-034-506	Bushing, Plunger	2	29	545-007-115	Nut, Hex (7/16-14 Stainless)	16
9	170-006-115	Cap Screw, Hex Head (3/8-16 x 1 Stainless)	4		545-007-330	Nut, Hex (7/16-14 Zinc Plated Steel)	16
	170-006-330	Cap Screw, Hex Head (3/8-16 x 1 Zinc Plated Steel)	4	30	560-001-360	O-ring, Plunger Pin	2
	171-059-115	Cap Screw, Socket Head (3/8-16 x 2 1/2 Stainless (Pulse Output Kit)	4	31	560-011-360	O-ring, Adapter Plate	2
	171-059-330	Cap Screw, Socket Head (3/8-16 x 2 1/2 Zinc Plates Steel (Pulse Output Kit)	4	32	560-033-360	O-ring, Sensor Bushing	2
		Cap Screw, Hex Head (3/8-16 x 2-1/2 Stainless)	16	33	560-200-360	O-ring	1
		Cap Screw, Hex Head (3/8-16 x 2-1/2 Zinc Plated Steel)	16	34	560-201-360	O-ring, Probe Tip	2
10	170-052-115	Cap Screw, Hex Head (7/16-14 x 2 Stainless)	16	35	612-240-147	Plate, Air Inlet Adapter	1
	170-052-330	Cap Screw, Hex Head (7/16-14 x 2 Zinc Plated Steel)	16	36	612-194-010	Plate Assy, Outer Diaphragm (Cast Iron Units)	2
11	170-060-115	Cap Screw, Hex Head (7/16-14 x 2 Stainless)	16		612-194-110	Plate Assy, Outer Diaphragm (Stainless Units)	2
	170-060-330	Cap Screw, Hex Head (7/16-14 x 2 Zinc Plated Steel)	16		612-194-157	Plate Assy, Outer Diaphragm (Aluminum Units)	2
12	170-121-115	Cap Screw, Hex Head (5/16-18 x 5 1/2 Stainless)	4		612-039-010	Plate Assy, Outer Diaphragm (Cast Iron Units w/ Overlay)	2
	170-121-330	Cap Screw, Hex Head (5/16-18 x 5 1/2 Zinc Plated Steel)	4		612-097-110	Plate Assy, Outer Diaphragm (Stainless Units w/ Overlay)	2
13	171-059-330	Cap Screw, Socket Flat Head (7/16-14 x 1-1/4)	8		612-039-157	Plate Assy, Outer Diaphragm (Aluminum Units w/ Overlay)	2
14	171-082-115	Cap Screw, Socket Head (5/16-18 x 1-1/4 Stainless)	4	37	612-231-150	Plate, Inner Diaphragm	2
	171-082-330	Cap Screw, Socket Head (5/16-18 x 1-1/4 Zinc Plated Steel)	4		612-239-150	Plate, Inner Diaphragm (Overlay Diaphragm)	2
15	171-100-115	Cap Screw, Socket Head (5/16-18 x 2-1/2 Stainless)	4	38	620-020-115	Plunger, Actuator	2
16	196-167-010	Chamber, Outer (Cast Iron Units)	2	39	675-042-115	Ring, Retaining	2
	196-167-110	Chamber, Outer (Stainless Units)	2	40	685-058-120	Rod, Diaphragm	1
	196-167-112	Chamber, Outer (Alloy-C Units)	2	41	720-004-360	Seal, Diaphragm Rod	2
	196-167-157(156)	Chamber, Outer (Aluminum Units)	2	42	722-040-360	Seat, Buna	4
17	196-205-157	Chamber, Inner	1		722-040-363	Seat, FKM	4
18	196-206-157	Chamber, Inner	1		722-040-364	Seat, EPDM	4
19	286-007-354	Diaphragm, Santoprene	2		722-040-365	Seat, Neoprene	4
	286-007-356	Diaphragm, Hytrel	2		722-040-550	Seat, UHMW Polyethylene	4
	286-007-360	Diaphragm, Nitrile	2		722-040-600	Seat, PTFE	4
	286-007-363	Diaphragm, FKM	2		722-040-080	Seat, Carbon Steel (must use with seals - item #41)	4
	286-007-364	Diaphragm, EPDM	2		722-040-110	Seat, Stainless (must use with seals - item #41)	4
	286-007-365	Diaphragm, Neoprene	2		722-040-150	Seat, Aluminum (must use with seals - item #41)	4
20	286-020-604	Diaphragm, Teflon Overlay	2	43	560-106-360	Seal, Nitrile O-ring	8
21	360-093-360	Gasket, Main Air Valve	1		560-106-363	Seal, FKM O-ring	8
22	360-104-379	Gasket, Air Inlet Cap	1		560-106-364	Seal, EPDM O-ring	8
23	360-112-365	Gasket, Inner Chamber	2		560-106-365	Seal, Neoprene O-ring	8
24	360-114-360	Gasket, Pilot Valve	1		720-060-608	Seal, Conductive PTFE	8
25	518-145-010	Manifold, Suction (Cast Iron Units)	1	44	724-006-000	Sensor Assembly, AirVantage	1
	518-145-010E	Manifold, Suction (Cast Iron Units)	1	45	846-001-167	Tip, AirVantage Probe	2
	518-145-110	Manifold, Suction (Stainless Units)	1	46	894-014-000	Valve, Check	1
	518-145-110E	Manifold, Suction (Stainless Units)	1	46a	031-206-000	Cartridge, Check Valve	1
	518-145-112	Manifold, Suction (Alloy-C Units)	1	47	900-005-115	Washer, 3/8 lock (Stainless)	16
	518-145-112E	Manifold, Suction (Alloy-C Units)	1		900-005-330	Washer, 3/8 lock (Zinc Plated Steel)	16
	518-145-156	Manifold, Suction (Aluminum Units)	1				
	518-145-156E	Manifold, Suction (Aluminum Units)	1				

Composite Repair Parts Kits

Available Service And Conversion Kits

Air End Kit - 476.281.000 (RS20 Only)

Seals, O-rings, Gaskets, Retaining Rings, Air Valve Assembly and Pilot Valve Assembly

Wet End Kit – 476.042.354 (RS20, S20 metal)

Santoprene Diaphragms, Balls and EPDM Seats

Wet End Kit – 476.042.360 (RS20, S20 metal)

Nitrile Diaphragms, Balls and Seats

Wet End Kit – 476.042.364 (RS20, S20 metal)

EPDM Diaphragms, Balls and Seats

Wet End Kit – 476.042.365 (RS20, S20 metal)

Neoprene Diaphragms, Balls and Seats

Wet End Kit – 476.042.633 (RS20, S20 metal)

FKM Diaphragms, PTFE Balls and FKM Seats

Wet End Kit – 476.042.635 (RS20, S20 metal)

Neoprene Diaphragms, PTFE overlays, PTFE Balls and Seats

Wet End Kit – 476.042.654 (RS20, S20 metal)

Santoprene Diaphragms, PTFE Overlays, PTFE Balls and Seats

Wet End Kit – 476.042.656 (RS20, S20 metal)

Santoprene Diaphragms, Balls and EPDM Seats

Sensor Kit - 476.284.000

(Sensor, Probe Tips and O-rings)

Poppet Valve Kit – 476.289.000

(Poppet Valve Assembly, O-ring)

Poppet Valve Assembly Kit – 476.290.000

(Poppet Valve Assembly, O-ring, Regulator and Pilot Valve)

Control Module Kit – 476.291.000 (Power Gen AirVantage Only)

(Control Module Assembly, Gaskets, Hardware and O-rings)

Power Gen Kit – 476.293.000 (Power Gen AirVantage Only)

(Power Gen, Gasket, Hardware and O-ring)

Seal Kit – 476.280.000

O-rings and Gaskets

Probe Tip Kit – 476.283.000

(Probe Tips and O-rings)

Midsection Upgrade Kit – 475.XXX.000 Consult Factory

(Replaces S20 Metallic Midsection with AirVantage Components)

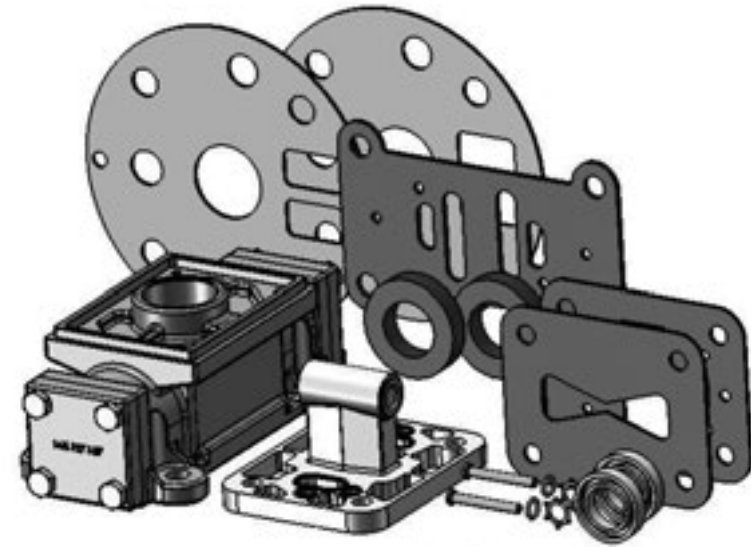

AIR END KIT



WETTED END KIT

Composite Repair Parts Drawing: Wetted Side

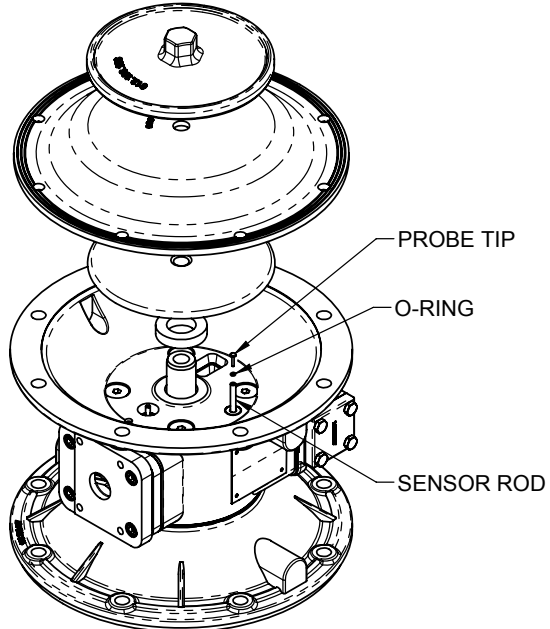
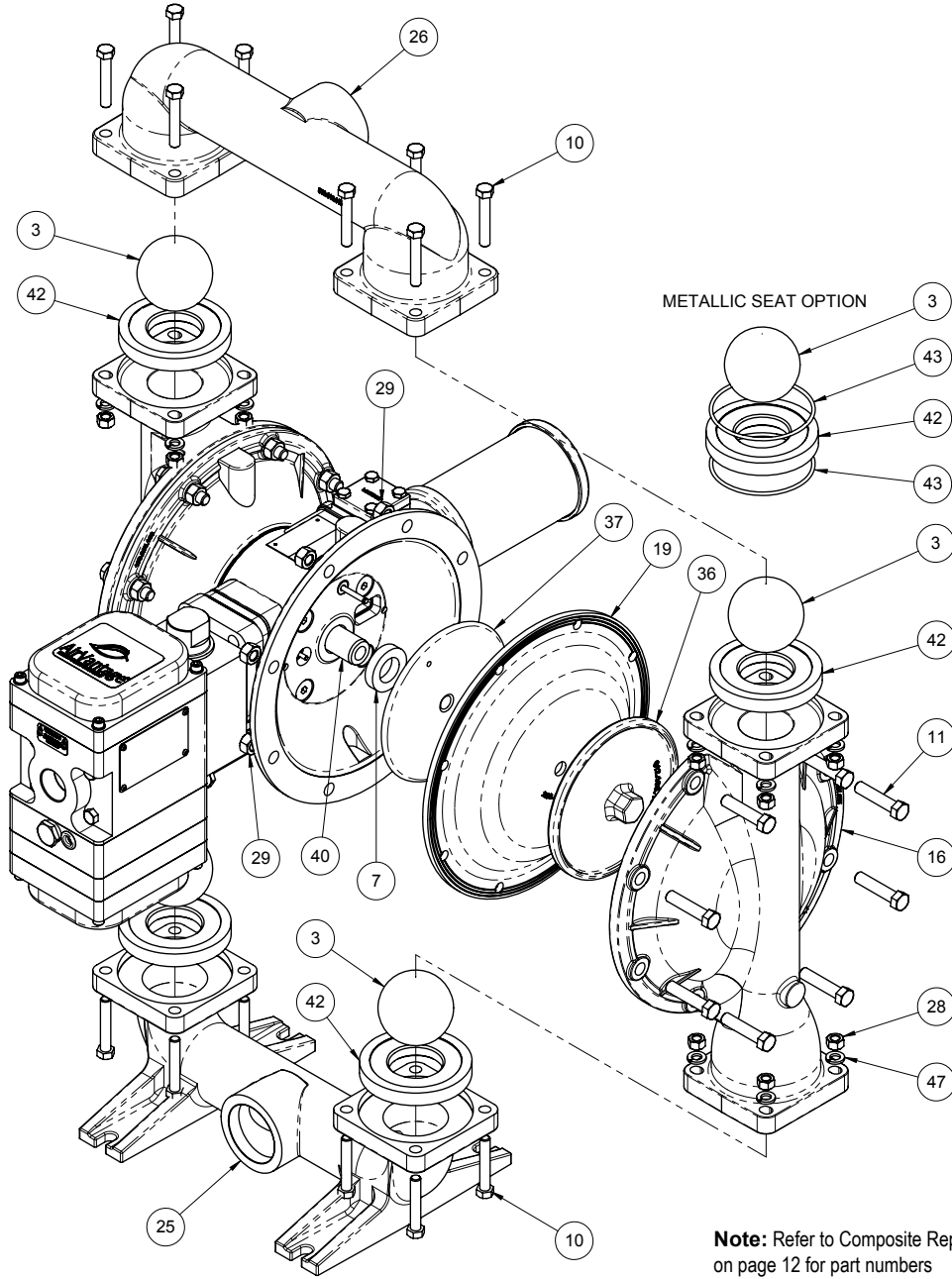

PROBE TIP DETAIL

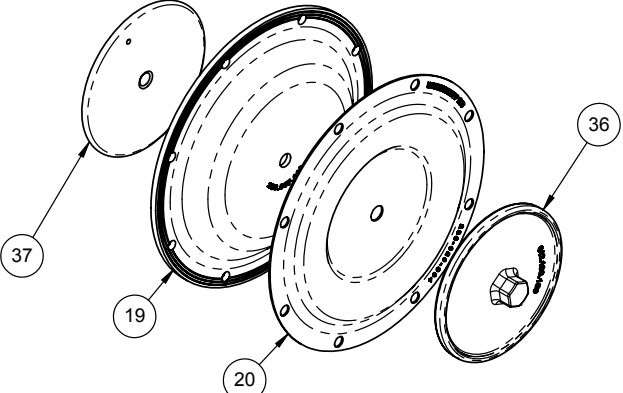

OVERLAY DIAPHRAGM OPTION

Note: Refer to Composite Repair Parts List on page 12 for part numbers

DIAPHRAGM AND CHECK VALVE SERVICING

- To service the diaphragms, first shut off and bleed the air being supplied to the pump. For safety purposes the air supply line should be disconnected from the pump.
- Then shut off the suction and discharge lines to the pump.
- Bleed the pressure from the pump suction and discharge lines and remove the lines from the pump.
- Drain any remaining liquid from the pump.
- During the servicing of the diaphragms, consult the “Composite Repair Parts Drawing” (p.7).

Step #1: Removing the Manifolds

- Using a 9/16" wrench or socket, remove the 16 cap-screws, hex-nuts, and lockwashers that fasten the manifolds to the outer chambers.
- Remove the manifolds.

Step #2: Inspect Check Valve Components

- Inspect the four check balls for wear, abrasion or cuts on the spherical surface. Also inspect the four check valve seats for cuts, abrasive wear or embedded material around the area where the ball contacts the seat.
- For maximum pump performance and efficiency, the surface of the ball must seal against the seat without any gaps.
- Replace worn or damaged parts as necessary. Consult the “Composite Repair Parts Drawing” for part numbers and quantities.

Step #3: Removing the Outer Chambers

- Using an 11/16" and a 5/8" wrench or socket, remove the 16 cap-screws, and hexnuts that fasten the outer chambers, diaphragms, and inner chambers.

Step #4: Removing the Diaphragm Assemblies

- Once the outer chambers are removed, use a 1-1/16" (27mm) wrench or six-pointed socket to remove the diaphragm assemblies (outer plate, diaphragm, and inner plate) from the diaphragm rod by turning counterclockwise.
- **“AirVantage CAUTION” – When diaphragm assemblies are removed, watch for the brass probe tips located on the end of the sensor rod. There is one brass probe tip and one o-ring per side. Inspect the probe tips and o-rings for wear. For every diaphragm service, these parts should be replaced and are available in kit form. Consult the “Composite Repair Parts Drawing” for part numbers and quantities.**
- The diaphragm connecting rod will usually stay with one of the diaphragm assemblies. Install the rod in a vise fitted with soft jaws and loosen the diaphragm assembly from the rod. Take care not to scar the surface of the rod.
- Insert a 1/4-20 capscrew or set screw into the smaller tapped hole in the inner diaphragm plate.
- Insert the protruding stud and the 1/4-20 fastener loosely into a vise. Use the 1-1/16" wrench or socket to remove the outer diaphragm plate by turning counter-clockwise.

Step #5: Inspect Diaphragms, Diaphragm Connecting Rod, U-cup Seals and Bumpers

- Inspect the diaphragms for cuts and/or punctures in the flexing area. Even the smallest hole or crack can allow product to get to the air side of the pump. If there is product noticed on the air side of the diaphragm, there is a good possibility the diaphragm needs to be replaced.
- **“AirVantage CAUTION” – If product is observed on the air side of the diaphragm, refer to the “AirVantage Servicing” section of the service manual.**
- Abrasive wear of the diaphragm needs to be inspected at the point where the diaphragm contacts the outer chamber or where the diaphragm plates contacts the diaphragm. Chemical attack of a diaphragm will usually result in swelling or deformity. Replace the diaphragms if necessary. Inspect the diaphragm connecting rod for scars, nicks or any imperfection that could cause damage to the u-cup seal. Inspect the u-cup seal for imperfections on the sealing lip. Inspect the bumpers for damage on the face.

Replace components as necessary. Consult the “Composite Repair Parts Drawing” for part numbers and quantities.

Step #6: Assemble the Diaphragms

- Push the threaded stud of the outer diaphragm plate through the center hole of the diaphragm. Thread the inner plate clockwise onto the stud.
- Insert the loose assembly with the above 1/4-20 fastener back into the vise. Use a torque wrench and 1-1/16" socket (27 mm) to tighten the diaphragm assembly together to 480 in.-lbs. (54.23 Newton meters).
- Allow a torqued assembly to set for 15-minutes. This will allow the diaphragm to relax. Re-torque the assembly to compensate for stress relaxation in the clamped assembly.

Step #7: Installing the Diaphragm Assemblies to the Pump

- Make sure the bumper is installed over the diaphragm rod. Thread the stud of the one diaphragm assembly clockwise into the tapped hole at the end of the diaphragm rod until the inner diaphragm plate is flush to the end of the rod.
- **“AirVantage CAUTION” – With the pump lying on one inner chamber, pull the sensor rod UP the full length of its stroke. Insert the brass probe tip and o-ring into the sensor rod. Insert rod and diaphragm assembly into pump, taking care not to damage the u-cup seal. Make sure the diaphragm plate contacts the brass probe tip and stays in contact with it. This will help make sure the probe tip does not fall out during reassembly.**
- Align the bolt holes in the diaphragm with the bolt pattern in the inner chamber. Fasten the outer chamber to the pump, using the cap screws, and hex nuts, but do not tighten. Flip the pump over so that it is now setting on the outer chamber. Pull the diaphragm rod out as far as possible. Make sure the bumper is installed over the diaphragm rod.
- **“AirVantage CAUTION” – Install the second brass probe tip and o-ring on the sensor rod.**
- **Thread the stud of the remaining diaphragm assembly clockwise into the tapped hole at the end of the diaphragm rod (item 34) until the diaphragm plate contacts the end surface of the diaphragm rod. If the bolt holes in the diaphragm do not line up with the inner chamber, use a 1-1/16" (27 mm) socket or wrench to tighten the assembly until they line up.**
- Fasten the remaining outer chamber to the pump, using the cap screws and hex nuts, and once again, do not tighten at this point. Tip the pump 90° and set it on a flat surface with the discharge side of the chambers down. This will allow the outer chambers to be aligned with each other. Tighten the sixteen fasteners. Make sure to use a cross tightening pattern to ensure an even sealing on the diaphragm.

Step #8: Re-install the Check Valve Components and Manifolds

- While the pump is setting on the discharge side, insert the check balls and seats on the suction side of the pump. Make sure the seats fit within the counter bore of the chambers. The suction manifold can now be installed, using the eight cap screws, hex nuts and lock washers.
- Flip the pump 180° and install the seats and check balls on the discharge side.
- Now the discharge manifold can be installed and fastened using the remaining cap screws, hex nuts, and lock washers.

OVERLAY DIAPHRAGM SERVICING

The overlay diaphragm is a PTFE diaphragm that fits over the exterior of the diaphragm. The PTFE diaphragm is used to protect the standard diaphragm from the chemicals being pumped. Repeat step #6 when diaphragms need to be serviced.



! IMPORTANT
Read these instructions completely, before installation and start-up. It is the responsibility of the purchaser to retain this manual for reference. Failure to comply with the recommendations stated in this manual will damage the pump, and void factory warranty.

Composite Repair Parts Drawing: Air Side

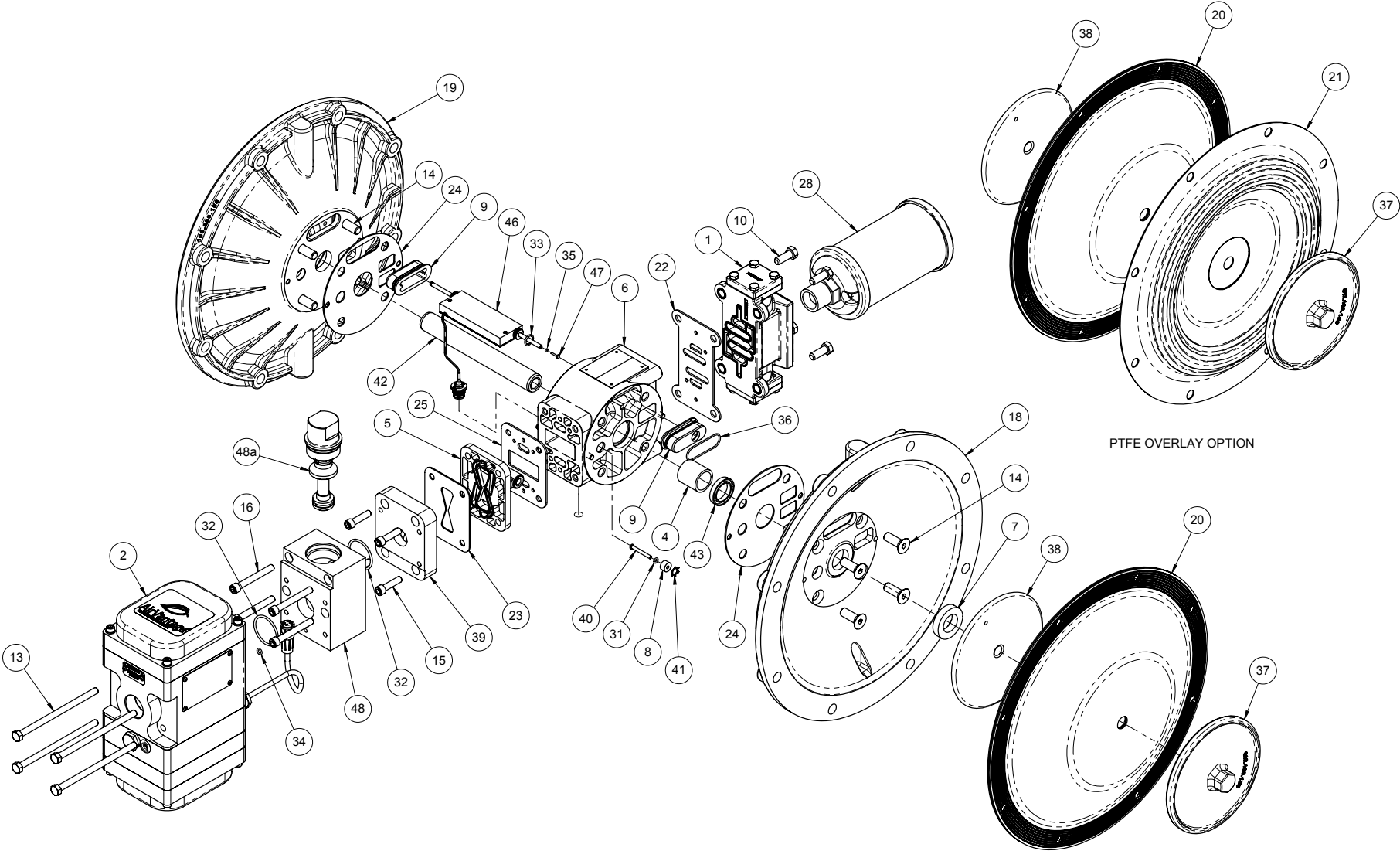

Note: Refer to Composite Parts List on page 12 for part numbers

INTERMEDIATE AND AirVantage SENSOR SERVICING

- To service the intermediate and AirVantage sensor, first shut off and bleed the air being supplied to the pump. For safety purposes, the air supply line should be disconnected from the pump. Shut off both the suction and discharge lines to the pump. Consult the "Composite Repair Parts Drawing".

Step #1: Remove the Patch Cable

- Twist the ribbed portion of the patch cable connector in a counterclockwise direction, until it unthreads from the connector. The cable can be removed from only the intermediate .

Step #2: Remove the AirVantage from the Pump

- Use a 1/2" socket and remove the four 5/16-18 x 5 cap screws that hold the AirVantage to the pump. Be sure to support the weight of the AirVantage while removing the last cap screw. After the AirVantage is removed from the pump, set the unit down on the plastic cover located on the bottom.

Step #3: Remove the Manifolds, Chambers, and Diaphragms (See Diaphragm Servicing Section)

Step #4: Remove the Diaphragm Assemblies

- Refer to the "Diaphragm Servicing" section of the manual to remove diaphragm assembly from the pump.
- "AirVantage CAUTION"** – When the diaphragm assembly is removed, watch for the brass probe tips located on the end of the sensor rod. There is one brass probe tip and one o-ring per side. Inspect the probe tips and o-rings for wear. For every diaphragm service, these parts should be replaced and are available in kit form. Consult the "Composite Repair Parts Drawing" for part numbers and quantities.

Step #5: Remove the Inner Chambers

- Use a 1/4" hex key wrench and remove the four flat head socket cap screws on each inner chamber. These bolts have been assembled using blue thread locker, so they may be difficult to remove. The inner chambers and gaskets can now be removed.
- "AirVantage CAUTION"** – Remove the inner chamber from the intermediate with caution, taking care not to damage the sensor. Inspect the gaskets and u-cup seals under each inner chamber and replace them as necessary.

Step #6: Accessing the Actuator Plunger Bushings and O-rings

- The actuator plunger pin bushings and o-rings can now be accessed. If it is determined that these parts need to be replaced, use a small screwdriver and remove the retaining rings.
- NOTE:** It is recommended that new retaining rings be installed after disassembly. The bushing and o-ring can now be removed and inspected.

Step #7: Accessing the AirVantage Sensor

- If the sensor needs to be replaced, use a 13/16" socket and remove the plastic nut securing the connector to the intermediate. Slide the connector out of the hole, taking care not to lose/misplace the gasket on the connector.
- The sensor can now be removed from the intermediate assembly.

Step#8: Reinstallation

- Slide the new sensor assembly in the intermediate.
- "AirVantage CAUTION"** – Make sure the cable assembly fits into the groove machined in the intermediate. Failure to do so may damage the cable during assembly.

- Feed the connector through the hole in the intermediate, making sure the gasket is on the connector before installation. The flat edge on the connector should line up with the inside of the intermediate. Install the nut and hand tighten it using a 13/16" socket.
- The inner chambers and gaskets can now be reinstalled. Use blue thread locker on the inner chamber bolts and torque them to 300 in-lbs.
- Refer to the "Diaphragm Servicing" section of the manual to finish the diaphragm installation procedure.

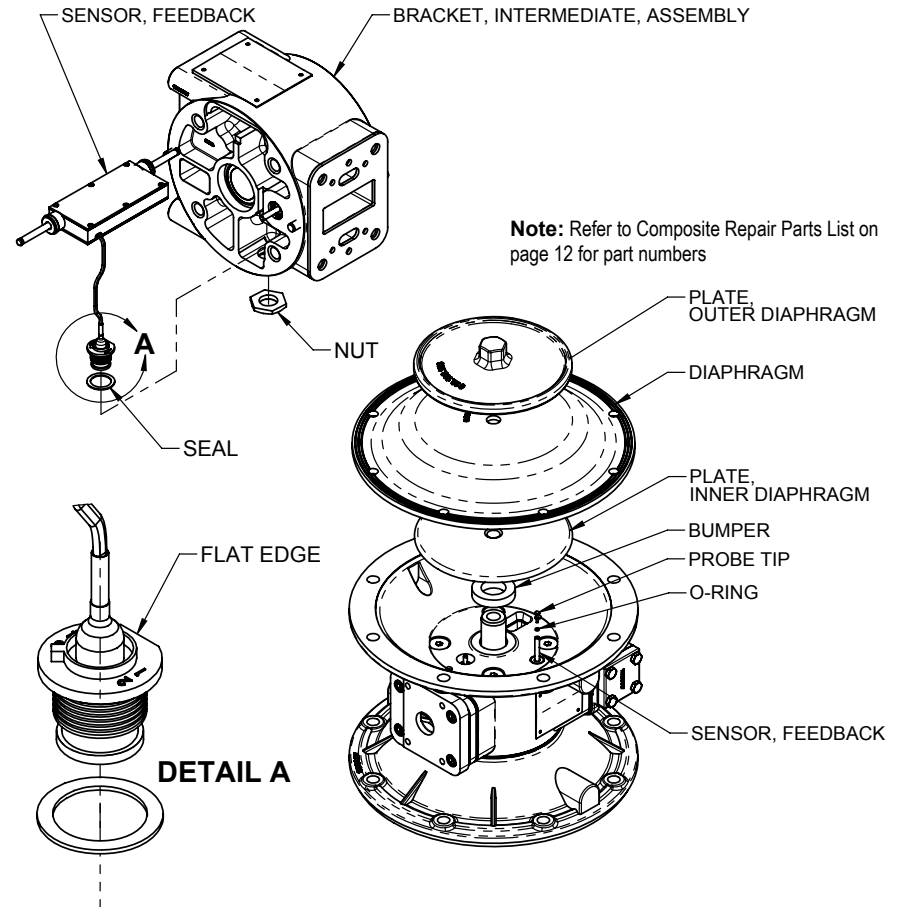

Air Valve Servicing, Assembly Drawing & Parts List

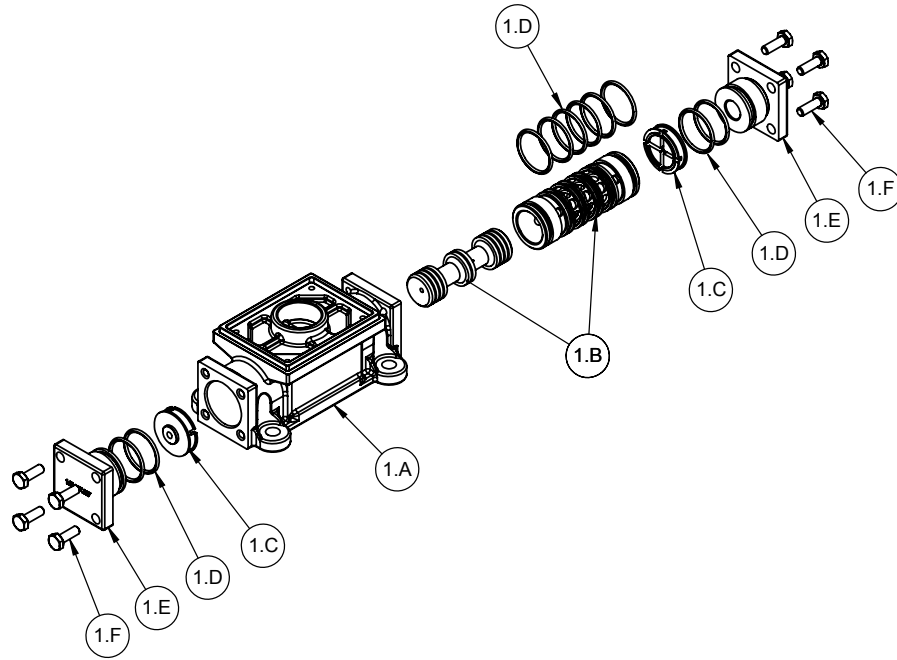

AIR VALVE ASSEMBLY PARTS LIST

Item	Part Number	Description	Qty
1	031-183-003	Air Valve Assembly	1
1-A	095-109-157	Body, Air Valve	1
1-B	031-139-162	Sleeve and Spool Set	1
1-C	132-029-357	Bumper	2
1-D	560-020-360	O-Ring	10
1-E	165-127-157	Cap, End	2
1-F	170-032-330	Hex Head Capscrew 1/4-20 x .75	8

AIR DISTRIBUTION VALVE SERVICING

To service the air valve, first shut off the compressed air, bleed pressure from the pump, and disconnect the air supply line from the pump.

Step #1:

- Using a 9/16" wrench or socket, remove the four hex capscrews. Remove the air valve assembly from the pump.
- Remove and inspect gasket for cracks or damage. Replace gasket if needed.

Step #2: Disassembly of the air valve.

- Using a 7/16" wrench or socket, remove the eight hex capscrews that fasten the end caps to the valve body. Next, remove the two end caps. Inspect the two o-rings on each end cap for damage or wear. Replace the bumpers as needed.
- Remove the bumpers. Inspect the bumpers for damage or wear. Replace the bumpers as needed.
- Remove the spool from the sleeve. Be careful not to scratch or damage the outer diameter of the spool. Wipe spool with a soft cloth and inspect for scratches or wear.
- Inspect the inner diameter of the sleeve for dirt, scratches, or other contaminants. Remove the sleeve if needed and replace with a new sleeve and spool set.

Step #3: Reassembly of the air valve.

- Install one bumper and one end cap, with two o-rings, and fasten with four hex capscrews to the valve body.
- Remove the new sleeve and spool set from the plastic bag. Carefully remove the spool from the sleeve. Install the six o-rings into the six grooves on the sleeve. Apply a light coating of grease to the o-rings before installing the sleeve into the valve body, align the slots in the sleeve with the slots in the valve body. Insert the spool into the sleeve. Be careful not to scratch or damage the spool during installation. Carefully insert the sleeve into the bumper and end cap (with o-rings) and fasten with the remaining hex capscrews.
- Fasten the air valve assembly and gasket to the pump. Connect the compressed air line to the pump. The pump is now ready for operation.



! IMPORTANT

Read these instructions completely, before installation and start-up. It is the responsibility of the purchaser to retain this manual for reference. Failure to comply with the recommendations stated in this manual will damage the pump, and void factory warranty.

Air Valve with Stroke Indicator Assembly Drawing and Parts List

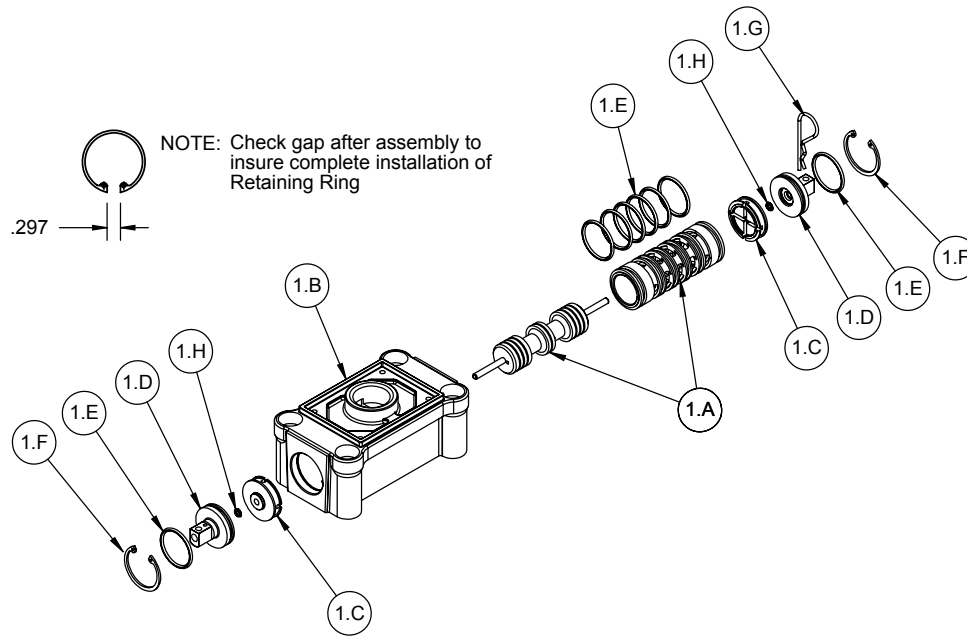

AIR VALVE ASSEMBLY PARTS LIST

Item	Part Number	Description	Qty
1	031-147-003	Air Valve Assembly	1
1-A	031-143-162	Sleeve and Spool Set	1
1-B	095-094-559	Body, Air Valve	1
1-C	132-029-552	Bumper	2
1-D	165-098-147	Cap, End	2
1-E	560-020-360	O-Ring	8
1-F	675-044-115	Ring, Retaining	2
1-G	210-008-330	Clip, Safety	1
1-H	560-029-360	O-Ring	2

Air Distribution Valve With Stroke Indicator Option Servicing

To service the air valve first shut off the compressed air supply, bleed the pressure from the pump, and disconnect the air supply line from the pump.

Step #1: See COMPOSITE REPAIR PARTS DRAWING.

- Using a 5/16" Allen wrench, remove the four hex socket capscrews and four flat washers. Remove the air valve assembly from the pump.
- Remove and inspect gasket for cracks or damage. Replace gasket if needed.

Step #2: Disassembly of the air valve.

- To access the internal air valve components first remove the two retaining rings from each end of the air valve assembly using clip ring pliers.
- Next remove the two end caps. Inspect the o-ring for cuts or wear. Replace the o-rings if necessary.
- Remove the two bumpers. Inspect the bumpers for cuts, wear or abrasion. Replace if necessary.
- Remove the spool from the sleeve. Be careful not to scratch or damage the outer diameter of the spool. Wipe spool with a soft cloth and inspect for scratches or wear.
- Inspect the inner diameter of the sleeve for dirt, scratches, or other contaminants. Remove the sleeve if needed and replace with a new sleeve and spool set.

Step #3: Reassembly of the air valve.

- Install one bumper and one end cap with o-rings into one end of the air valve body. Install one retaining ring, into the groove on the same end. Insert the safety clip through the smaller unthreaded hole in the endcap.
- Remove the new sleeve and spool set from the plastic bag. Carefully remove the spool from the sleeve. Install the six o-rings into the six grooves on the sleeve. Apply a light coating of grease to the o-rings before installing the sleeve into the valve body. Align the slots in the sleeve with the slots in the valve body. Insert the spool into the sleeve. Be careful not to scratch or damage the spool during installation. Push the spool in until the pin touches the safety clip on the opposite end.
- Install the remaining bumper, end cap with o-rings and retaining ring.
- Fasten the air valve assembly and gasket to the pump.
- Connect the compressed air line to the pump. Remove the safety clip. The pump is now ready for operation.



! IMPORTANT

Read these instructions completely, before installation and start-up. It is the responsibility of the purchaser to retain this manual for reference. Failure to comply with the recommendations stated in this manual will damage the pump, and void factory warranty.

Pilot Valve and Actuator Plunger Servicing

To service the pilot valve or the actuator plungers, first shut off and bleed the air being supplied to the pump. For safety purposes the air supply line should be disconnected from the pump. Then shut off the suction and discharge lines to the pump. Bleed the pressure from the pump suction and discharge lines and remove the lines from the pump.

Step #1: Remove the Patch Cable

- Twist the ribbed portion of the patch cable connector in a counterclockwise direction, until it unthreads from the connector. The cable can either be removed from the intermediate or from the control module.

Step #2: Remove the AirVantage from the Pump

- Use a ½" socket and remove the four 5/16-18 x 5 cap screws that hold the AirVantage to the pump. Be sure to support the weight of the AirVantage while removing the last cap screw. After the AirVantage is removed from the pump, carefully set the unit down on the plastic cover located on the bottom.

Step #3: Remove the Air Inlet Adapter Plate Adapter

- Use a ¼" hex key wrench and remove the four 5/16-18 x 1 ¼ socket head cap screws. This will allow access to the pilot valve, gaskets and actuator plungers.

Step #4: Disassemble the Pilot Valve

- Remove the pilot spool and wipe it clean. Inspect the spool and o-rings for dirt, cuts or wear. Replace parts if necessary.
- Use a set of outside snap ring pliers and remove the retaining ring holding the sleeve in the pilot valve body. Gently push the sleeve from the body and wipe it clean. Inspect the sleeve and o-rings. Replace parts if necessary.

Step #5: Reassemble the Pilot Valve

- Generously lubricate the o-rings on the pilot sleeve with multipurpose grease (BP-LSEP-2 or equivalent). Carefully insert the sleeve in the pilot valve body, taking care not to shear any of the o-rings. Install the retaining ring.
- Generously lubricate the o-rings on the pilot spool. Carefully insert the spool in the sleeve.

Step #6: Inspect the Actuator Plungers

- With the pilot valve assembly off the pump, the actuator plungers can be accessed.
- Remove the plungers and inspect them for nicks or unusual wear. Replace them if necessary. If the bushings or o-rings need to be replaced, refer to the Intermediate Servicing section (p.17). Apply a generous amount of lubricant and install the plungers back in the intermediate. Push them as far in as they will go.

Step #7: Reassembly

- Reinstall the pilot valve and gaskets. Take caution during the installation to align the ends of the pilot valve stem between the plunger pins. If the pilot valve does not fit flush against the gasket, check to make sure the actuator plunger are pushed all the way. Failure to do so may cause damage to the pilot valve or the actuators.

Step #8: Reassemble AirVantage and Cable

- Reinstall the AirVantage using the four 5/16-18 x 5 cap screws and torque to 90 in-lbs.
- Reattach the patch cable connector that connects the AirVantage module to the intermediate.

ITEM NO.	PART NUMBER	DESCRIPTION	QTY.
5.A	095.095.157	BODY, PILOT VALVE	1
5.B	755.051.148	SLEEVE, PILOT VALVE	1
5.C	560.033.360	O-RING	6
5.D	775.055.110	SPOOL, PILOT VALVE	1
5.E	560.023.360	O-RING	3
5.F	675.037.080	RING, RETAINING	1

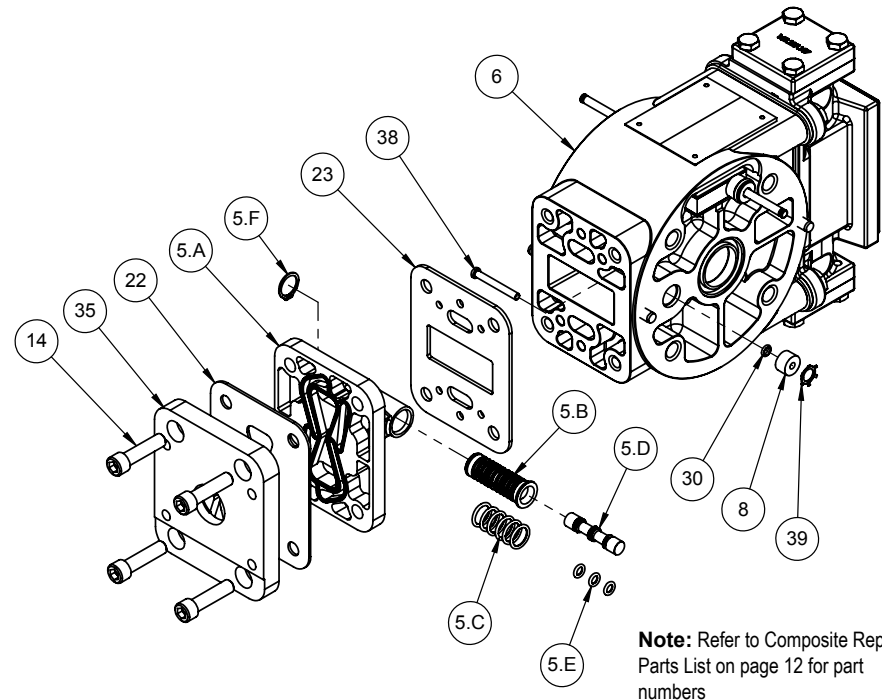

Pulse Output Kit Drawing

PULSE OUTPUT KIT OPTION

This pump can be fitted with a Pulse Output Kit. This converts the mechanical strokes of the pump to an electrical signal which interfaces with the Stroke Counter/ Batch Controller or user control devices such as a PLC.

The Pulse Output Kits mount directly onto the Muffler Cap on the Air Distribution Valve Assembly or onto the air valve and senses each stroke of the main spool.

Consult the factory for further information and availability.

Pulse Output Kits

475-244-003

10-30VDC, 110VAC and 220 VAC

Intrinsically Safe

5-30 VDC, 110-120VAC, 220-240VAC

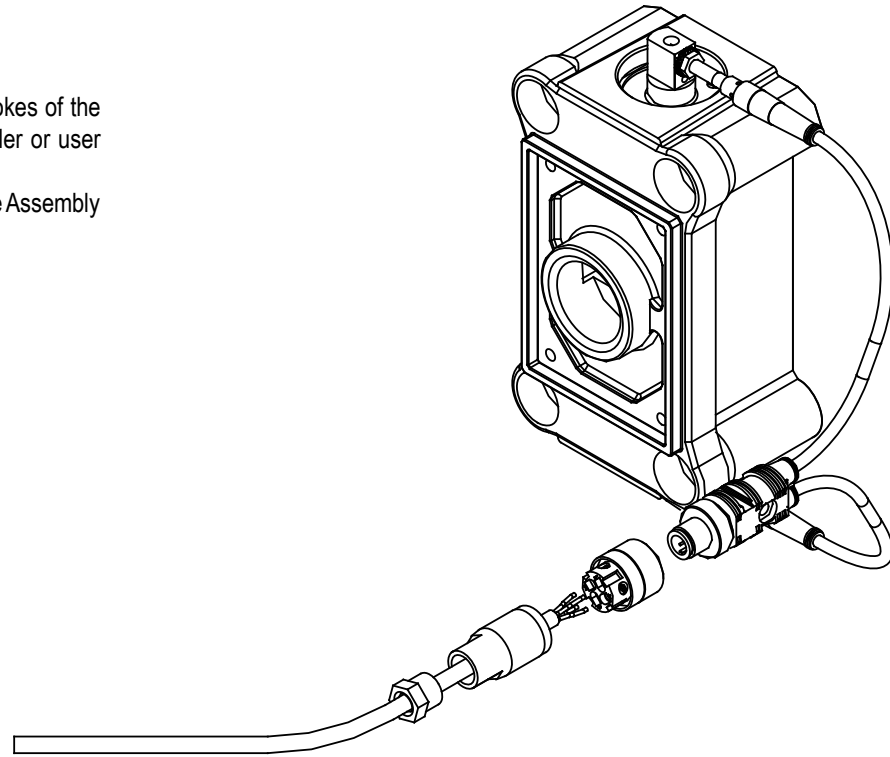

This Page Intentionally Blank

Composite Repair Parts Drawing: AirVantage Unit

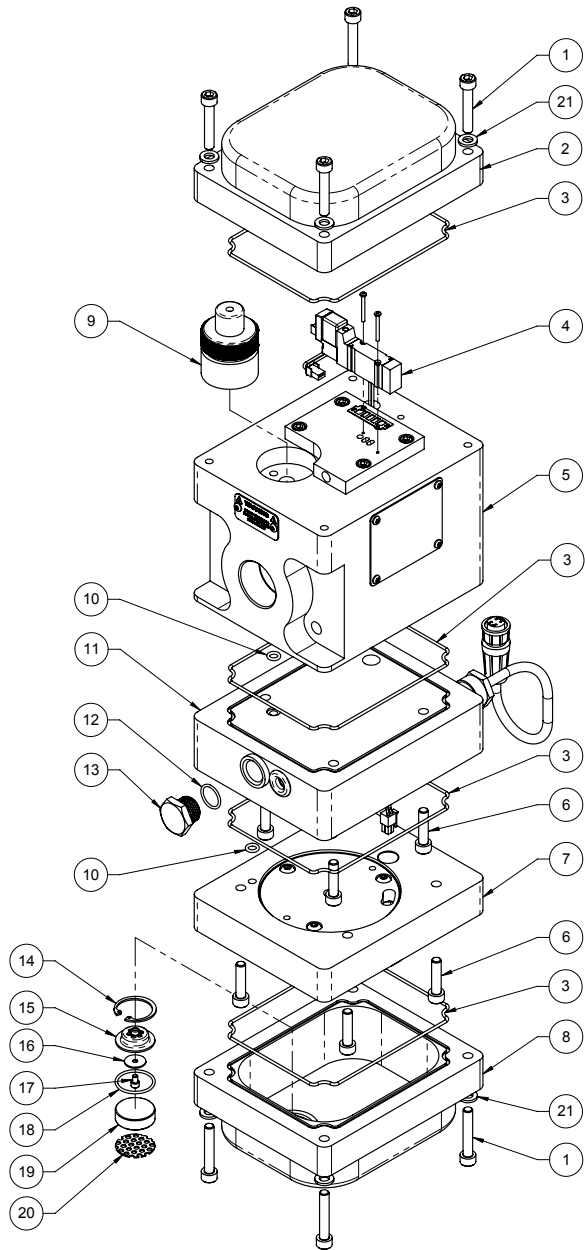

AirVantage Composite Parts List

ITEM No.	PART NUMBER	DESCRIPTION	QTY.
1	171.092.115	CAPSCREW, HEX SOC HD, M6-1.0 x35	8
2	258.020.000	COVER	1
3	720.004.360	SEAL, O-RING	4
4	765.004.000	VALVE, SOLENOID	1
5	893.104.000	VALVE, POPPET	1
6	171.091.115	CAPSCREW, HEX SOC HD, M6-1.0 x25	8
7	031.202.000	POWER GENERATION MODULE	1
8	258.019.000	COVER, END	1
9	020.069.000	REGULATOR	1
10	560.200.360	SEAL, O-RING	2
11	249.019.000	CONTROL MODULE, RS20	1
12	560.104.360	SEAL, O-RING	1
13	165.135.330	CAP, SWITCH	1
14	675.067.115	RING, RETAINING	1
15	430.050.147	CAP, DUST	1
16	720.073.365	VALVE, DUST	1
17	171.093.115	CAPSCREW, HEX SOC HD, 5-40 x.25	1
18	560.205.360	SEAL, O-RING	1
19	530.045.115	ARRESTOR, SPARK	1
20	165.137.115	PLATE, PERFORATED	1
21	901.051.115	WASHER, FLAT, M6	8



AirVantage Servicing - Pilot Valve and Pressure Regulator

Pilot Valve and Pressure Regulator

To service the pilot valve or the pressure regulator, first shut off and bleed the air being supplied to the pump. For safety purposes the air supply line should be disconnected from the pump. Then shut off the suction and discharge lines to the pump. Bleed the pressure from the pump suction and discharge lines and remove the lines from the pump. During the servicing of the AirVantage, consult the "AirVantage Composite Repair Parts Drawing".

Step #1: Remove the Patch Cable

- Twist the ribbed portion of the patch cable connector in a counterclockwise direction, until it unthreads from the connector. The cable can be removed only from the intermediate.

Step #2: Remove the AirVantage from the Pump

- Use a 1/2" socket and remove the four 5/16-18 x 5 cap screws that hold the AirVantage to the pump. Be sure to support the weight of the AirVantage while removing the last cap screw. After the AirVantage is removed from the pump, set the unit down on the plastic cover located on the bottom. Inspect the o-ring between the poppet valve and the adapter plate for damage.

Step #3: Access the Pilot Valve and Pressure Regulator

- Use a 5mm hex-key wrench and remove four M6 x 35mm socket head cap screws & washers securing the top cover on. Lift the cover off, exposing the pilot valve and pressure regulator. There is a molded o-ring seal located on the underside of the cap. Make sure the o-ring stays located within the groove.
- If the pilot valve needs to be replaced, unplug the connector attached to it. Use a miniature 4-way Phillips screwdriver and remove the two screws holding the pilot valve to the plate. The valve and gasket can now be removed and/replaced. When reinstalling the pilot valve, tighten the screws to snug with a miniature 4-way Phillips screwdriver.
- **"AirVantage CAUTION"** – Be sure to reattach the connector to the pilot valve.
- If the pressure regulator needs to be replaced, use slip-joint pliers to unscrew the regulator from the body by turning it in a counterclockwise direction.
- **"AirVantage CAUTION"** – Do not loosen or tighten the regulator by turning the knurled portion of the unit. Place the slip-joint pliers on the smooth area underneath the knurled area of the regulator.

Step #4: Reinstallation

- Reinstall the top cover, making sure the o-ring seal is still in the groove. Tighten the four M6 screws.
- Reinstall the AirVantage using the four 5/16-18 x 5 cap screws and torque to 90 in-lbs.
- **"AirVantage CAUTION"** – Be sure to reattach the patch cable connector that connects the AirVantage module to the intermediate.

Note: Ensure all mating faces are free from scores or damage prior to re-assembly. Check each metallic face joint with a 0.003" feeler gage to ensure all flange faces are fully closed after assembly. Failure to do so may compromise the flameproof design of the assembly.

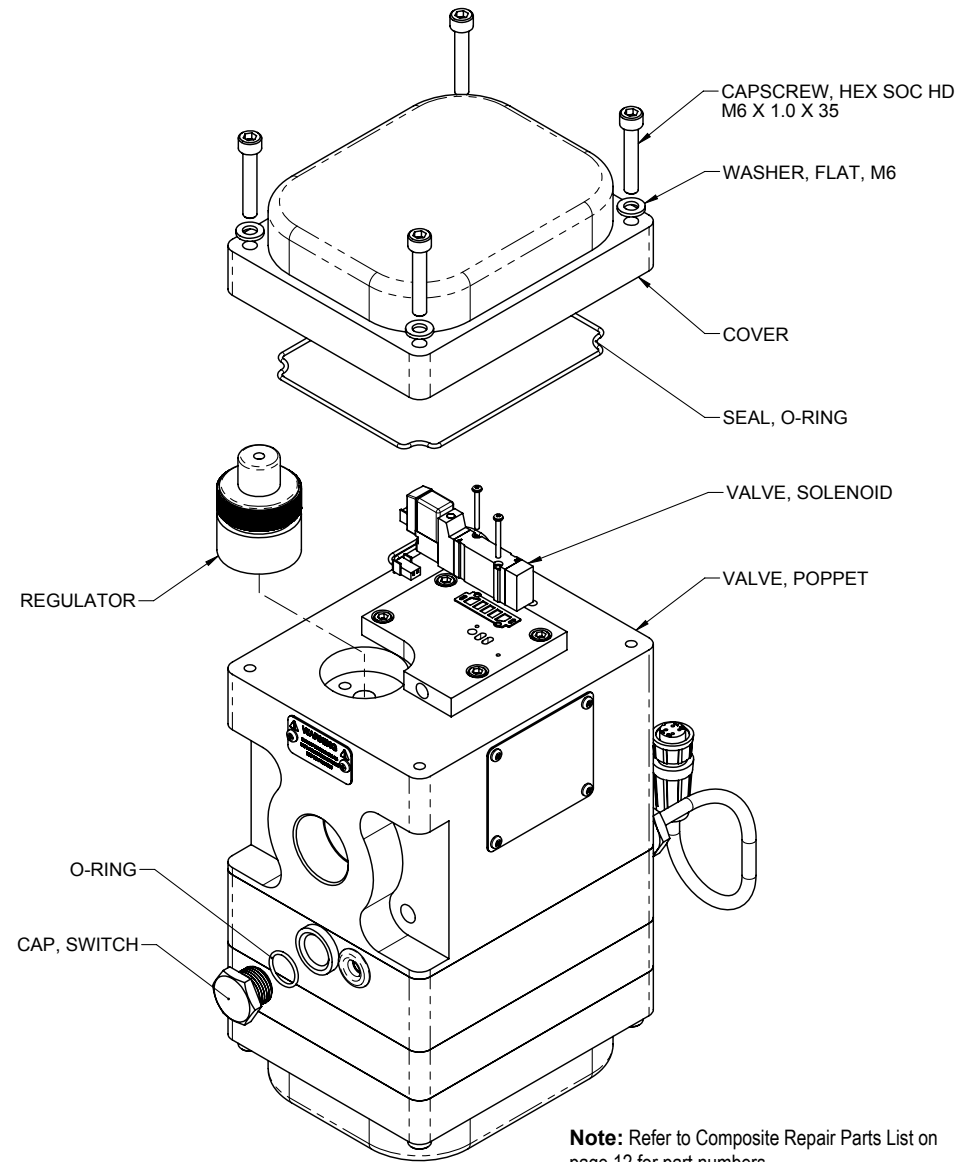

Note: Refer to Composite Repair Parts List on page 12 for part numbers



AirVantage Servicing - Power Generation Module

To service the power generation module, first shut off and bleed the air being supplied to the pump. For safety purposes the air supply line should be disconnected from the pump. Then shut off the suction and discharge lines to the pump. Bleed the pressure from the pump suction and discharge lines and remove the lines from the pump. During the servicing of the AirVantage, consult the "AirVantage Composite Repair Parts Drawing".

Step #1: Remove the Patch Cable

- Twist the ribbed portion of the patch cable connector in a counterclockwise direction, until it unthreads from the connector. The cable can be removed only from the intermediate.

Step #2: Remove the AirVantage from the Pump

- Use a 1/2" socket and remove the four 5/16-18 x 5 cap screws that hold the AirVantage to the pump. Be sure to support the weight of the AirVantage while removing the last cap screw. After the AirVantage is removed from the pump, set the unit down on the plastic cover located on the top of the unit. Inspect the o-ring between the poppet valve and the adapter plate for damage.

Step #3: Access the Power Generation Module

- Use a 5mm hex-key wrench and remove four M6 x 35mm socket head cap screws & washers securing the bottom cover. Lift the bottom cover off, exposing the power generation module. There is a molded o-ring seal located on the underside of the cap. Make sure the o-ring stays located within the groove.
- If the power generation module needs to be replaced, unplug the connector that connects the power generator to the control board. Use a 5mm hex-key wrench and remove four M6 x 25mm socket head cap screws. The power generation module should now be loose. Carefully lift the power generation module off the rest of the assembly, making sure that the control board wire and connector slips through the hole in the power generation case.
- "AirVantage CAUTION" - Take caution not to loosen the o-ring that seals between the components.**

Step #4: Reinstallation

- When reinstalling the new module make sure to feed the control module wire through the hole in the power generation case. Install the four M6 x 25mm socket head cap screws and tighten to 6.8 N-M.
- "AirVantage CAUTION" – Be sure to reattach the connector from the power generator to the control board.**
- Reinstall the bottom cover, making sure the o-ring seal is still in the groove. Tighten the four M6 x 35 socket head cap screws to 3.4 N-M.
- Reinstall the top cover, making sure the o-ring seal is still in the groove. Tighten the four M6 screws. Reinstall the AirVantage using the four 5/16-18 x 5 cap screws and torque to 90 in-lbs.
- "AirVantage CAUTION" – Be sure to reattach the patch cable connector that connects the AirVantage module to the intermediate.**

Note: Ensure all mating faces are free from scores or damage prior to re-assembly. Check each metallic face joint with a 0.003" feeler gage to ensure all flange faces are fully closed after assembly. Failure to do so may compromise the flameproof design of the assembly.

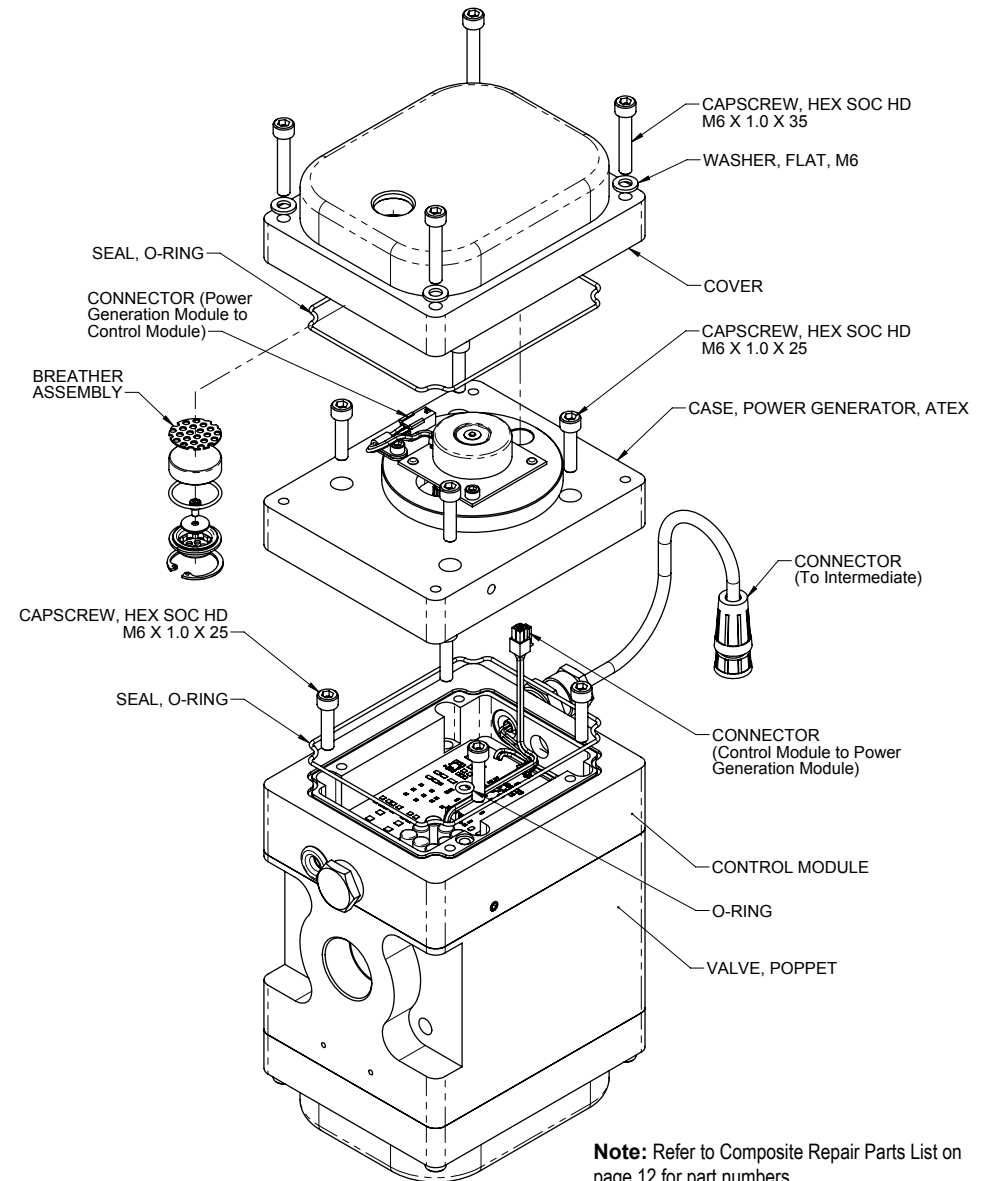

AirVantage Servicing - Control Module

To service the control module, first shut off and bleed the air being supplied to the pump. For safety purposes the air supply line should be disconnected from the pump. Then shut off the suction and discharge lines to the pump. Bleed the pressure from the pump suction and discharge lines and remove the lines from the pump. During the servicing of the AirVantage, consult the "AirVantage Composite Repair Parts Drawing".

Step #1: Remove the Patch Cable

- Twist the ribbed portion of the patch cable connector in a counterclockwise direction, until it unthreads from the connector. The cable can be removed only from the intermediate.

Step #2: Remove the AirVantage from the Pump

- Use a 1/2" socket and remove the four 5/16-18 x 5 cap screws that hold the AirVantage to the pump. Be sure to support the weight of the AirVantage while removing the last cap screw. After the AirVantage is removed from the pump, set the unit down on the plastic cover located on the bottom. Inspect the o-ring between the poppet valve and the adapter plate for damage.

Step #3: Access the Pilot Valve

- Use a 5mm hex-key wrench and remove four M6 x 35mm socket head cap screws & washers securing the top cover on. Lift the cover off, exposing the pilot valve. There is a molded o-ring seal located on the underside of the cap. Make sure the o-ring stays located within the groove. The connector will need to be removed from the pilot valve. Once the plug has been removed, feed the wire assembly into the hole in the valve body to the point where the connector just enters the valve body. Reinstall the top cover and loosely reinstall the bolts. The connector will eventually need to be reconnected.

Step #4: Access the Control Module

- Use a 5mm hex-key wrench and remove four M6 x 35mm socket head cap screws & washers securing the bottom cover on. Lift the bottom cover off, exposing the power generation module. There is a molded o-ring seal located on the underside of the cap. Make sure the o-ring stays located within the groove.
- Unplug the connector that connects the power generator to the control board. Use a 5mm hex-key wrench to loosen the four M6 x 25mm socket head cap screws. The power generation module should now be loose. Carefully lift the power generation module off the rest of the assembly, making sure that the control board wire and connector slips through the hole in the power generation case.
- **"AirVantage CAUTION" - Take caution not to lose the o-ring that seals between the components.**
- If the control module needs to be replaced, use a 5mm hex-key wrench to loosen the four M6 x 25mm socket head cap screws holding the control module to the poppet assembly. The control module should now be loose. Carefully lift the control module off the poppet assembly, making sure that the pilot valve connector wire slips through the hole in the poppet valve assembly.
- **"AirVantage CAUTION" - Take caution not to loosen the o-ring that seals between the components.**

Note: Ensure all mating faces are free from scores or damage prior to re-assembly. Check each metallic face joint with a 0.003" feeler gage to ensure all flange faces are fully closed after assembly. Failure to do so may compromise the flameproof design of the assembly.

Step #5: Reinstalling

- When reinstalling the new control module, make sure to feed the pilot valve connector wire through the hole in the poppet valve assembly. Install the four M6 x 25mm socket head cap screws and tighten to 3.4 N-M.
- Reinstall the power generation module. Make sure to feed the control module wire through the hole in the power generation case. Install the four M6 x 25mm socket head cap screws and tighten to 6.8 N-M.
- **"AirVantage CAUTION" – Be sure to reattach the connector from the power generator to the control board.**
- Reinstall the top cover, making sure the o-ring seal is still in the groove. Tighten the four M6 screws. Reinstall the AirVantage using the four 5/16-18 x 5 cap screws and torque to 90 in-lbs.
- **"AirVantage CAUTION" – Be sure to reattach the patch cable connector that connects the AirVantage module to the intermediate.**

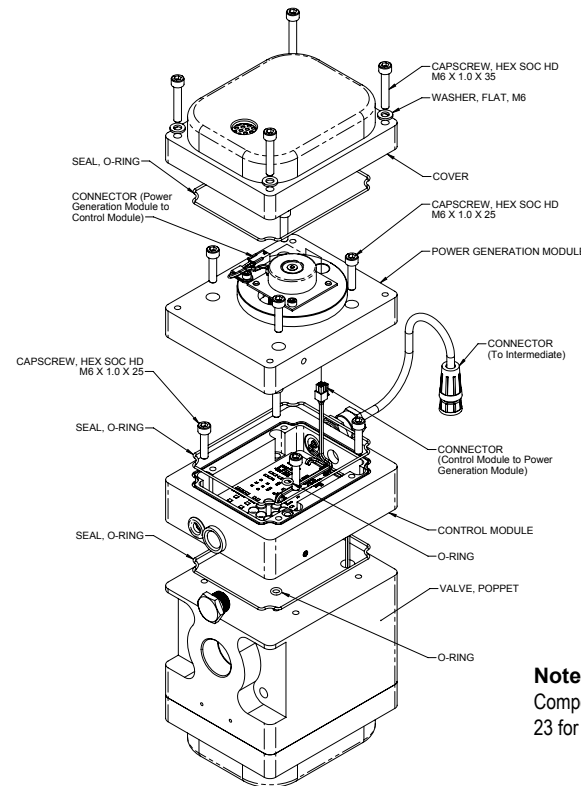

Note: Refer to AirVantage Composite Repair Parts List on page 23 for part numbers



AirVantage Servicing - Sensor Assembly

To service the control module, first shut off and bleed the air being supplied to the pump. For safety purposes the air supply line should be disconnected from the pump. Then shut off the suction and discharge lines to the pump. Bleed the pressure from the pump suction and discharge lines and remove the lines from the pump. During the servicing of the AirVantage, consult the "AirVantage Composite Repair Parts Drawing".

Step #1: Remove the Patch Cable

- Twist the ribbed portion of the patch cable connector in a counterclockwise direction, until it unthreads from the connector. The cable can be removed only from the intermediate.

Step #2: Remove the AirVantage from the Pump

- Use a 1/2" socket and remove the four 5/16-18 x 5 cap screws that hold the AirVantage to the pump. Be sure to support the weight of the AirVantage while removing the last cap screw. After the AirVantage is removed from the pump, set the unit down on the plastic cover located on the bottom. Inspect the o-ring between the poppet valve and the adapter plate for damage.

Step #3: Diaphragm Disassembly

- Refer to the "Diaphragm Servicing" section (p.15) of the manual to remove diaphragm assembly from the pump.
- "AirVantage CAUTION"** – When the diaphragm assembly is removed, watch for the brass probe tips located on the end of the sensor rod. There is one brass probe tip and one o-ring per side. Inspect the probe tips and o-rings for wear. For every diaphragm service, these parts should be replaced and are available in kit form. Consult the "Composite Repair Parts Drawing" for part numbers and quantities.

Step #4: Accessing the Sensor Assembly

- Use a 1/4" hex key wrench and remove the four, flat head socket cap screws on each inner chamber. These bolts have been assembled using blue thread locker, so they may be difficult to remove. The inner chambers and gaskets can now be removed.
- "AirVantage CAUTION"** – Remove the inner chamber from the intermediate with caution, taking care not to damage the sensor.
- If the sensor needs to be replaced, use a 13/16" socket and remove the plastic nut holding the connector to the intermediate. Slide the connector out of the hole.
- The sensor can now be removed from the intermediate assembly.

Step #5: Reinstallation

- Slide the new sensor assembly in the intermediate.
- "AirVantage CAUTION"** – Make sure the cable assembly fits into the groove machined in the intermediate. Failure to do so may damage the cable during assembly.
- Feed the connector through the hole in the intermediate and install the plastic nut. Hand tighten the nut using a 13/16" socket. Make sure the gasket is to the inside of the intermediate.
- The inner chambers and gaskets can now be reinstalled. Use blue thread locker on the inner chamber bolts and torque them to 300 in-lbs.
- Refer to the "Diaphragm Servicing" section of the manual to finish the diaphragm installation procedure.

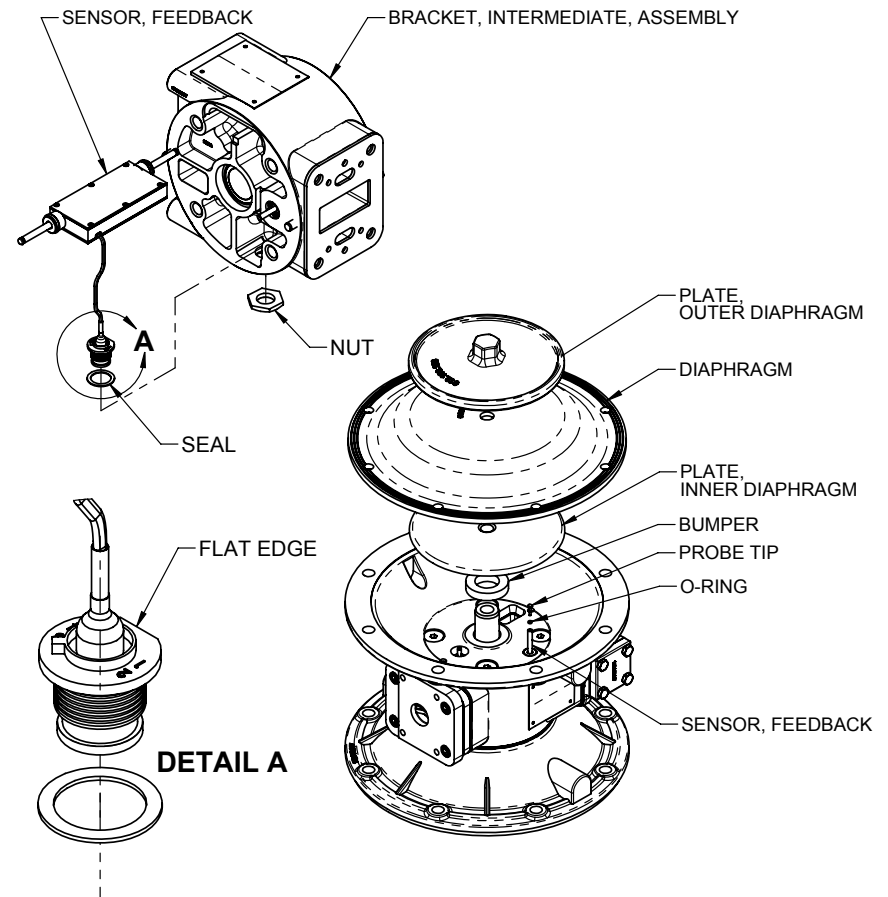

Note: Refer to Composite Repair Parts List on page 12 for part numbers



AirVantage Servicing - Poppet Valve Drawing

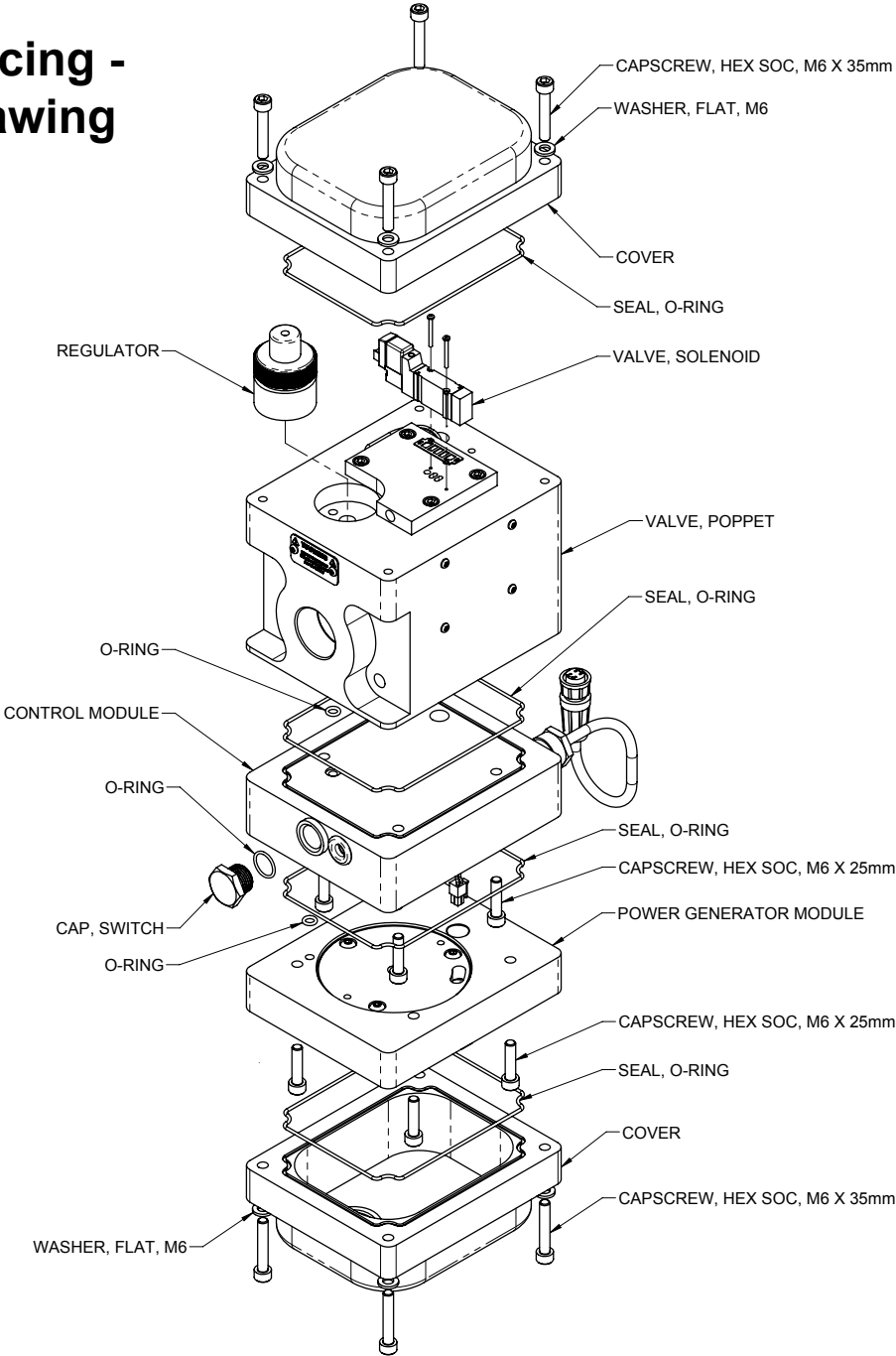

Caution: When performing a direct spray washdown, the AirVantage exhaust outlet should be covered with protective tape. Failure to do so may damage internal components. (See page 23)

AirVantage Servicing - Poppet Valve

Step #1: Remove the Patch Cable

- Twist the ribbed portion of the patch cable connector in a counterclockwise direction, until it unthreads from the connector. The cable can be removed from only the intermediate.

Step #2: Remove the AirVantage from the Pump

- Use a ½" socket and remove the four 5/16-18 x 5 cap screws that hold the AirVantage to the pump. Be sure to support the weight of the AirVantage while removing the last cap screw. After the AirVantage is removed from the pump, set the unit down on the plastic cover located on the bottom. Inspect the o-ring between the poppet valve and the adapter plate for damage.

Step #3: Access the Pilot Valve and Pressure Regulator

- Use a 5mm hex-key wrench and remove four M6 x 35mm socket head cap screws & washers securing the top cover on. Lift the cover off, exposing the pilot valve and pressure regulator. There is a molded o-ring seal located on the underside of the cap. Make sure the o-ring stays located within the groove.
- Unplug the connector attached to it. Use a miniature 4-way Phillips screwdriver and remove the two screws securing the pilot valve to the plate. The valve and gasket can now be removed and/or replaced.
- Use slip-joint pliers to unscrew the regulator from the body by turning it in a counterclockwise direction.
- **“AirVantage CAUTION” – Do not loosen or tighten the regulator by turning the knurled portion of the unit. Place the slip-joint pliers on the smooth area underneath the knurled area of the regulator. Reinstall the top cover and loosely reinstall the bolts. Turn the assembly over and let it now rest on the top cover.**

Step #4: Access the Power Generation Module

- Use a 5mm hex-key wrench and remove four M6 x 35mm socket head cap screws & washers securing the bottom cover on. Lift the bottom cover off, exposing the power generation module. There is a molded o-ring seal located on the underside of the cap. Make sure the o-ring stays located within the groove.
- Unplug the connector that connects the power generator to the control board. use a 5mm hex-key wrench to loosen the four M6 x 25mm socket head cap screws. The power generation module should now be loose. Carefully lift the power generation module off the rest of the assembly, making sure that the control board wire and connector slips through the hole in the power generation case.

Step #5: Access the Control Module

- Use a 5mm hex-key wrench and loosen the four M6 x 25mm socket head cap screws securing the control module to the poppet assembly. The control module should now be loose. Carefully lift the control module off the poppet assembly, making sure that the pilot valve connector wire slips through the hole in the poppet valve assembly.
- The Poppet valve assembly can now be replaced.

Step #6: Reinstallation

- Install the control module on the poppet valve assembly. Make sure to feed the pilot valve connector wire through the hole in the poppet valve assembly. Install the four M6 x 25mm socket head cap screws and tighten to 3.4 N-M.
- Install the power generation module onto the control module. Make sure to feed the control module wire through the hole in the power generation case. Install the four M6 x 25mm socket head cap screws and tighten to 6.8 N-M.
- **“AirVantage CAUTION” – Be sure to reattach the connector from the power generator to the control board.**
- Install the bottom cover, making sure the o-ring seal is still in the groove. Tighten the four M6 screws. The unit can now be turned over and set on the bottom cover.
- Install the pilot valve, tighten the screws snug with a miniature 4-way Phillips screwdriver.
- **“AirVantage CAUTION” – Be sure to reattach the connector to the pilot valve.**
- **“AirVantage CAUTION” – Be sure to reattach the patch cable connector that connects the AirVantage module to the intermediate.**
- If the pressure regulator needs to be replaced, use slip-joint pliers to unscrew the regulator from the body by turning it in a counterclockwise direction.
- **“AirVantage CAUTION” – Do not loosen or tighten the regulator by turning the knurled portion of the unit. Place the slip-joint pliers on the smooth area underneath the knurled area of the regulator.**

Step #7: Reinstallation

- Reinstall the top cover, making sure the o-ring seal is still in the groove. Tighten the four M6 screws.
- Reinstall the AirVantage using the four 5/16-18 x 5 cap screws and torque to 90 in-lbs.
- **“AirVantage CAUTION” – Be sure to reattach the patch cable connector that connects the AirVantage module to the intermediate.**
- **Refer to Page 28 for Illustration**

Note: Ensure all mating faces are free from scores or damage prior to re-assembly. Check each metallic face joint with a 0.003" feeler gage to ensure all flange faces are fully closed after assembly. Failure to do so may compromise the flameproof design of the assembly.



AirVantage Servicing - Check Valve

AirVantage - Check Valve Assembly

To service the check valve, first shut off and bleed the air being supplied to the pump. For safety purposes the air supply line should be disconnected from the pump. Then shut off the suction and discharge lines to the pump. Bleed the pressure from the pump suction and discharge lines and remove the lines from the pump. During the servicing of the AirVantage, consult the "AirVantage Composite Repair Parts Drawing" (Page 11)

Step #1: Remove the Patch Cable

Twist the ribbed portion of the patch cable connector in the counterclockwise direction, until it un-threads from the connector. The cable can be either be removed from the intermediate or from the control module.

Step #2: Remove the AirVantage from the Pump

Use a ½" socket and remove the four 5/16 x 5 ½ cap screws that hold the AirVantage to the pump. Remove the two chamber bolts/nuts that are holding the right side bracket to be able to remove the right bracket and the AirVantage unit from the pump. Be sure to support the weight of the AirVantage while removing the last cap screw. After the AirVantage is removed from the pump, set the unit down on the plastic cover located on the bottom. Inspect the o-ring between the poppet valve and adapter plate for damage.

Step 3: Remove the Check Valve from the Pump

Use a ½" socket and remove the four 5/16 x 2 ½ cap screw that holds the check valve to the pump.

Step 4: Inspect Check Valve

Using a 1 ¼" open socket wrench, remove the cartridge valve. Inspect o-rings and mechanism for any signs of wear, degradation, or damage. If any is present, replace with new cartridge valve assembly. Remove any remaining fluid contamination on inside of body and/or cartridge valve. Be careful not to lose the large and small o-rings on either face of the check valve body.

Step 5: Re-assembly of Check Valve

Apply a thin layer of white lithium grease to the threads on the valve cartridge. Insert cartridge valve into body and hand-tighten being careful not to pinch o-ring. Using a 9" torque wrench with crow-foot, torque cartridge valve to 250 in-lbs. Re-apply o-rings, as necessary, to both faces of check valve. After applying Blue Loctite 248, 222 (or equivalent) secure check valve back to pump with four 5/16 x 2 ½ cap screws, re-torque to 90 in-lbs.

To secure the AirVantage, re-install the four 5/16 x 5 ½ cap screws, torquing to 90 in-lbs. Re-install Patchcable.

Grounding The Pump

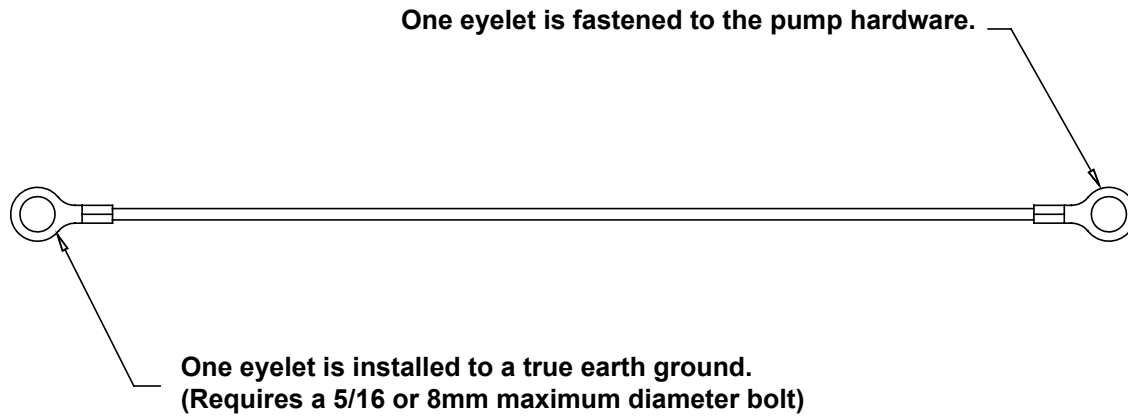

This 8-foot long (244 centimeters) Ground Strap, part number 920-025-000, can be ordered as a service item.

To reduce the risk of static electrical sparking, this pump must be grounded. Check the local electrical code for detailed grounding instruction and the type of equipment required.

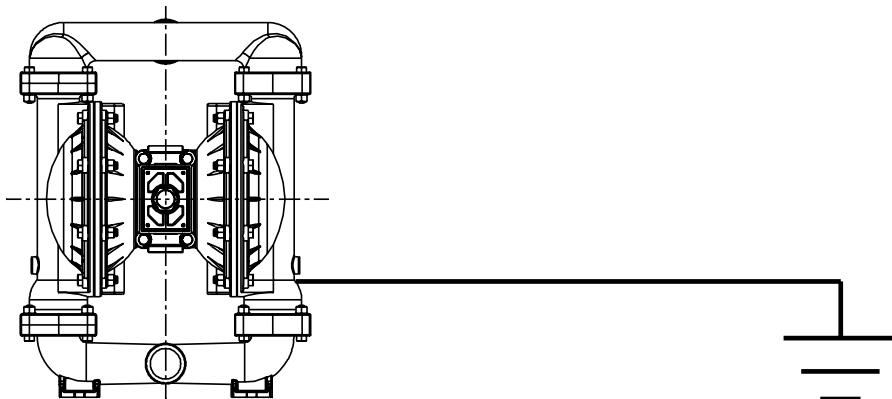

	! WARNING
	<i>Take action to prevent static sparking. Fire or explosion can result, especially when handling flammable liquids. The pump, piping, valves, containers or other miscellaneous equipment must be grounded.</i>

PUMPING HAZARDOUS LIQUIDS

- When a diaphragm fails, the pumped liquid or fumes enter the air end of the pump. Fumes are exhausted into the surrounding environment. When pumping hazardous or toxic materials, the exhaust air must be piped to an appropriate area for safe disposal. See illustration #1 at right.
- Piping used for the air exhaust must not be smaller than 1" (2.54 cm) diameter. Reducing the pipe size will restrict air flow and reduce pump performance. When the pumped product source is at a higher level than the pump (flooded suction condition), pipe the exhaust higher than the product source to prevent siphoning spills. See illustration #2 at right.

CONVERTING THE PUMP FOR PIPING THE EXHAUST AIR

- The following steps are necessary to convert the pump to pipe the exhaust air away from the pump.
- Remove the muffler. The air distribution valve has 1" NPT threads for piped exhaust.

IMPORTANT INSTALLATION NOTE:

- The manufacturer recommends installing a flexible conductive hose or connection between the pump and any rigid plumbing. This reduces stresses on the molded threads of the air exhaust port. Failure to do so may result in damage to the air distribution valve body.
- Failure to support these connections could also result in damage to the air distribution valve body.

CONVERTED EXHAUST ILLUSTRATION

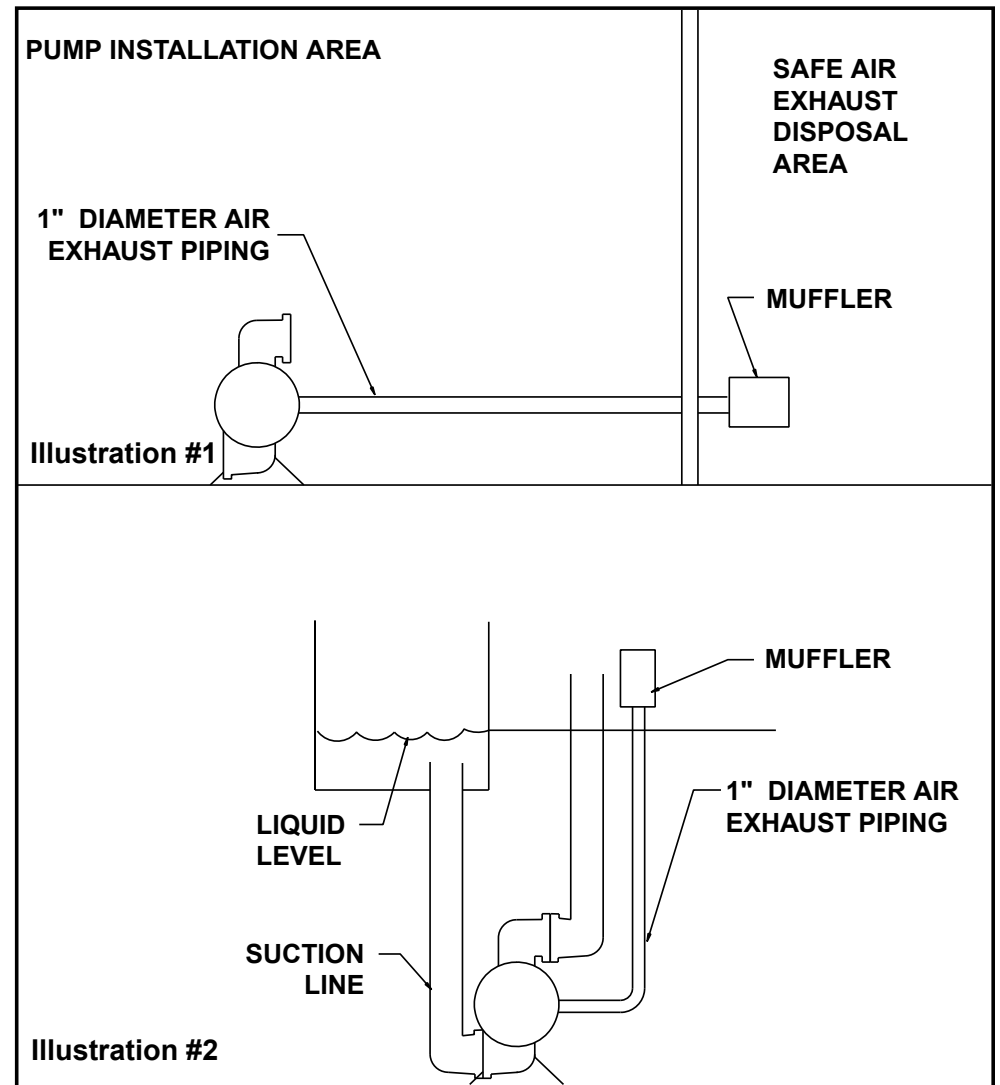

Material Codes

The Last 3 Digits of Part Number

000	Assembly, sub-assembly; and some purchased items	175	Die Cast Zinc	375	Fluorinated Nitrile	603	Blue Gylon
010	Cast Iron	180	Copper Alloy	378	High Density Polypropylene	604	PTFE
012	Powered Metal	305	Carbon Steel, Black Epoxy Coated	379	Conductive Nitrile	606	PTFE
015	Ductile Iron	306	Carbon Steel, Black PTFE Coated	405	Cellulose Fiber	607	Envelon
020	Ferritic Malleable Iron	307	Aluminum, Black Epoxy Coated	408	Cork and Neoprene	608	Conductive PTFE
025	Music Wire	308	Stainless Steel, Black PTFE Coated	425	Compressed Fiber	610	PTFE Integral Silicon
080	Carbon Steel, AISI B-1112	309	Aluminum, Black PTFE Coated	426	Blue Gard	611	PTFE Integral FKM
100	Alloy 20	310	PVDF Coated	440	Vegetable Fiber	632	Neoprene/Hytrel
110	Alloy Type 316 Stainless Steel	330	Zinc Plated Steel	465	Fiber	633	FKM (Fluorocarbon)/PTFE
111	Alloy Type 316 Stainless Steel (Electro Polished)	331	Chrome Plated Steel	500	Delrin 500	634	EPDM/PTFE
112	Alloy C	332	Aluminum, Electroless Nickel Plated	501	Delrin 570	635	Neoprene/PTFE
113	Alloy Type 316 Stainless Steel (Hand Polished)	333	Carbon Steel, Electroless Nickel Plated	502	Conductive Acetal, ESD-800	637	PTFE, FKM (Fluorocarbon)/PTFE
114	303 Stainless Steel	335	Galvanized Steel	503	Conductive Acetal, Glass-Filled	638	PTFE, Hytrel/PTFE
115	302/304 Stainless Steel	336	Zinc Plated Yellow Brass	505	Acrylic Resin Plastic	639	Nitrile/TFE
117	440-C Stainless Steel (Martensitic)	337	Silver Plated Steel	506	Delrin 150	643	Santoprene/EPDM
120	416 Stainless Steel (Wrought Martensitic)	340	Nickel Plated	520	Injection Molded PVDF Natural color	644	Santoprene/PTFE
123	410 Stainless Steel (Wrought Martensitic)	342	Filled Nylon	521	Conductive PVDF	650	Bonded Santoprene and PTFE
147	Clear Anodized Aluminum	353	Geolast; Color: Black	540	Nylon	654	Santoprene Diaphragm, PTFE Overlay Balls and seals
148	Hardcoat Anodized Aluminum	354	Injection Molded #203-40 Santoprene- Duro 40D +/-5; Color: RED	541	Nylon	656	Santoprene Diaphragm and Check Balls/EPDM Seats
149	2024-T4 Aluminum	355	Thermal Plastic	542	Nylon	661	EPDM/Santoprene
150	6061-T6 Aluminum	356	Hytrel	544	Nylon Injection Molded		
151	6063-T6 Aluminum	357	Injection Molded Polyurethane	550	Polyethylene		
152	2024-T4 Aluminum (2023-T351)	358	Urethane Rubber (Some Applications) (Compression Mold)	551	Glass Filled Polypropylene		Delrin and Hytrel are registered tradenames of E.I. DuPont.
154	Almag 35 Aluminum	359	Urethane Rubber	552	Unfilled Polypropylene		Gylon is a registered tradename of Garlock, Inc.
155	356-T6 Aluminum	360	Nitrile Rubber. Color coded: RED	553	Unfilled Polypropylene		Nylatron is a registered tradename of Polymer Corp.
156	356-T6 Aluminum	361	FDA Accepted Nitrile	555	Polyvinyl Chloride		Santoprene is a registered tradename of Exxon Mobil Corp.
157	Die Cast Aluminum Alloy #380	363	FKM (Fluorocarbon). Color coded: YELLOW	556	Black Vinyl		Rulon II is a registered tradename of Dixon Industries Corp.
158	Aluminum Alloy SR-319	364	E.P.D.M. Rubber. Color coded: BLUE	557	Unfilled Conductive Polypropylene		Ryton is a registered tradename of Phillips Chemical Co.
159	Anodized Aluminum	365	Neoprene Rubber. Color coded: GREEN	558	Conductive HDPE		Valox is a registered tradename of General Electric Co.
162	Brass, Yellow, Screw Machine Stock	366	Food Grade Nitrile	559	Glass-Filled Conductive Polypropylene		SANDPIPER, PortaPump, Tranquilizers and SludgeMaster are registered tradenames of Warren Rupp, Inc
165	Cast Bronze, 85-5-5-5	368	Food Grade EPDM	570	Rulon II		
166	Bronze, SAE 660	370	Butyl Rubber. Color coded: BROWN	580	Ryton		
167	Bronze, Alloy 954, ASTM B505	371	Phlithane (Tuftane)	590	Valox		
170	Bronze, Bearing Type, Oil Impregnated	374	Carboxylated Nitrile	591	Nylatron G-S		
				592	Nylatron NSB		
				600	PTFE (virgin material) Tetrafluorocarbon (TFE)		
				601	PTFE (Bronze and moly filled)		
				602	Filled PTFE		

**WARREN
RUPP, INC.®**

Declaration of Conformity

**Manufacturer: Warren Rupp, Inc.®, 800 N. Main Street
Mansfield, Ohio, 44902 USA**

Certifies that Air-Operated Double Diaphragm Pump Series: HDB, HDF, M Non-Metallic, S Non-Metallic, M Metallic, S Metallic, T Series, G Series, U Series, EH and SH High Pressure, RS Series, W Series, SMA and SPA Submersibles, and Tranquilizer® Surge Suppressors comply with the European Community Directive 2006/42/EC on Machinery, according to Annex VIII. This product has used Harmonized Standard EN809:1998+A1:2009, Pumps and Pump Units for Liquids - Common Safety Requirements, to verify conformance.

David Roseberry
Signature of authorized person

David Roseberry
Printed name of authorized person

Revision Level: F

October 20, 2005
Date of issue

Engineering Manager
Title

August 23, 2012
Date of revision

IBEX
FLUID & METERING

CE

WARREN RUPP, INC.[®]

EC Declaration of Conformity

In accordance with ATEX Directive 94/9/EC,
Equipment intended for use in potentially explosive environments.

Manufacturer: Warren Rupp, Inc.[®], A Unit of IDEX Corporation
800 North Main Street, P.O. Box 1568, Mansfield, OH 44902 USA

AirVantage-equipped ATEX-Certified Air-Operated
Double Diaphragm Pump Models RHDB2,
RHDF2, RS20, and RS30.

Certificate Number:
Sira 10ATEX1151X Issue: 2
Equipment: AirVantage Air Flow Control Unit

Sira Certification Service
Rake Lane
Eccleston
Chester
CH4 SJN
United Kingdom



Applicable Standard:

AirVantage

EN 60079-0:2009
EN 60079-1:2007
IEC 60079-31:2006

Marking:

II 2 G D
Ex d ib IIB T4 Gb
Ex tb IIIC 135° C Db IP66

Position Sensor

EN 60079-0:2006
EN 60079-11:2007
EN 61241-0:2006
EN 61242-11:2006

Rating (not marked):

II 2 G D
Ex ib IIB T4
Ex ibD 21 T132° C



DATE/APPROVAL/TITLE:
27 MAY 2010

David Roseberry
David Roseberry, Engineering Manager

WARREN RUPP, INC.[®]

Declaration of Conformity

INTERNATIONAL ELECTROTECHNICAL COMMISSION
IEC Certification Scheme for Explosive Atmospheres

Manufacturer: Warren Rupp, Inc.[®], A Unit of IDEX Corporation
800 North Main Street, P.O. Box 1568, Mansfield, OH 44902 USA

Airvantage-equipped Air-Operated Double
Diaphragm Pump Models RHDB2,
RHDF2, RS20 and RS30.

Certificate Number:
IECEX SIR 10.0110X Issue: 2
Equipment: AirVantage Air Flow Control
Unit

Sira Certification Service

Rake Lane
Ecclestone
Chester
CH4 SJN
United Kingdom

Applicable Standard:

AirVantage

IEC 60079-0:2004
IEC 60079-1:2007-4
IEC 60079-31:2008

Marking:

Ex d ib IIB T4 Gb
Ex tb IIIC 135° C Db IP66

Position Sensor

IEC 60079-0:2007-10
IEC 60079-11:2006
IEC 61241-0:2004
IEC 61242-11:2005

Rating (not marked):

Ex ib IIB T4
Ex ibD 21 T132° C



DATE/APPROVAL/TITLE:
27 MAY 2010



David Roseberry
David Roseberry, Engineering Manager