

OPERATING INSTRUCTIONS

This pump has been tested prior to shipment from factory. The oil reservoir has been partially filled at testing with air motor lubricant and should be completely filled before operation. When reservoir is full, the pump will not require refilling for approximately 50 hours of use. (See Lubrication Instructions.)

OPERATION

Your SludgeMaster is equipped with a muffler located at side of unit. Air exhaust port is located at top of muffler and a 3/4" NPT thread is provided to extend exhaust port above liquid being pumped. **Exhaust port must be extended above liquid to prevent liquid and foreign material from entering air motor when not in operation.** This can be done with a standard pipe, rigid plastic pipe, or hose as desired.

Connect air supply to air inlet fitting and submerge into liquid to be pumped. Unit requires 70 CFM maximum at 80 PSI (5.51 bar) air pressure. Operation at pressures in excess of 120 PSI (8.27 bar) is not recommended.

When handling liquid with large stones or similar solid objects, it is desirable to run unit at full speed. This provides greater inertia for handling heavy foreign objects without stoppage due to lodging between impeller and pump casing.

Should a foreign object lodge and prevent pump from rotating, insert a rod or bar through hole provided at bottom of strainer into impeller vanes and bump impeller backwards (clockwise facing strainer end) until free. Strainer can be removed when necessary; however, this normally will not be required.

LUBRICATION

The only regular servicing required is maintaining oil reservoir which is just as important on this unit for proper lubrication as the oil supply is for an engine. A one quart capacity oil reservoir is provided for bearing and shaft seal lubrication and provides oil for automatic air motor lubricator. Five drops of oil per minute is automatically dispensed into air stream for continuous air motor lubrication and to prevent rust formation due to moisture which is present in any air supply. Check and refill reservoir to oil fill plug level regularly with **Shell TELLUS[®] T Oil 32 Premium Multigrade AW Hydraulic Oil air motor lubricant**, or an equivalent lightweight oil with rust inhibitor. The automatic oiler will consume approximately 1 pint (473 cc) of oil in 50 hours of operation. Oil reservoir should be completely drained and refilled after approximately 100 hours operation to remove accumulated moisture.

It is beneficial to pour a little oil into air inlet connection and run for a few minutes before storing for long periods.

This unit is not harmed by running without liquid.

DISASSEMBLY

Remove upper row of six bolts and lift off air motor and upper housing assembly. Filter element and filter housing are now exposed and can be removed. Lower half of jaw type coupling is threaded on pump shaft and is removed by inserting drift pin through hole in shaft to prevent rotation while turning coupling counterclockwise with pipe wrench. **DO NOT USE JAWS OF COUPLING TO LOOSEN AS THEY CAN BE BROKEN.**

Remove spacer (item 25 on Repair Parts List) from shaft and remove governor housing assembly by lifting with screwdriver from each side. This is done by inserting screwdriver under male connectors (see Figure 1) and prying down on intermediate housing. Intermediate housing can now be removed by removing lower row of six bolts.



IMPORTANT

Read these safety warnings and instructions in this manual completely, before installation and start-up of the pump. It is the responsibility of the purchaser to retain this manual for reference. Failure to comply with the recommendations stated in this manual will damage the pump, and void factory warranty.



WARNING

Airborne particles and loud noise hazards. Wear ear and eye protection.



Figure 1



Figure 2

Remove strainer assembly secured with four cap nuts. Impeller is removed by inserting block of wood, hammer handle, or similar object between impeller vane and pump casing (see Figure 2) to prevent rotation and turn shaft counterclockwise from air motor end with drift pin inserted through hole in shaft. Remove shaft assembly from volute casing by removing snap ring above oil seal, bump shaft and bearing from casing. Rotating portion of shaft seal can now be removed from shaft and stationary seal seat can be removed from casing.

REASSEMBLY

When installing shaft seal on shaft use a lightweight oil and locate seal at extreme end of shaft so that carbon face of seal will contact seal seat before bearing enters housing bore during assembly. This eliminates the possibility of carbon washer falling out of position in seal cage while bumping shaft and bearing assembly into correct position. Push oil seal and retainer into bore above bearing and install snap ring. Install governor weights, spool and spring if removed. Lay o-ring into casing bore and install intermediate housing. Install o-ring and drop governor housing into position and push down into place. Slide sleeve and spacer onto shaft with spacer and shaft holes in alignment. Install coupling and tighten securely with drift pin and pipe wrench with same procedure as removal. (See Figure 3.) Insert o-ring into filter housing bore and press filter element and housing into position as shown. (See Figure 4.) Install o-ring into intermediate bore and o-ring on to counter bore at upper end of filter housing. Assembly is now ready to receive air motor and housing assembly. If coupling half on air motor shaft is removed, make certain coupling is relocated to correct position as indicated dimensionally in Figure 5. Line up coupling jaws for engagement by using bolt holes of castings as a reference. Rubber spider should be installed in lower coupling half. Lower air motor and housing into place slowly to feel for correct coupling engagement. When coupling is properly engaged, assembly can be pushed down by hand. **DO NOT FORCE ASSEMBLY TOGETHER WITH BOLTS.** If air motor assembly is lifted back up in attempting to engage blind coupling, make certain that o-ring on top end of filter housing is still in position. If o-ring is out of position during this blind assembly, air will by-pass the governor and over-speeding can occur. Fill with recommended oil and run unit without pumping to check for possible oil leakage at shaft seal or o-ring joints. Turn air supply on slowly to make certain that governor is operating properly.

WARRANTY

This unit is guaranteed for a period of five years against defective material and workmanship.

PERMANENT INSTALLATIONS

NOTE: As mentioned, the SMA3-A pump does require that oil be in the reservoir for bearing and motor lubrication. For permanent installations remove item 66, then plug the hole with a $\frac{1}{8}$ " pipe plug, part number 618-002-330. Fill the reservoir and make sure that an in-line oiler (type oil as recommended) is used in the air supply to the pump. Set lubricator at a usage rate of 1 pint (473 cc) every 50 hours. The motor will then be lubricated by the in-line oiler and the bearing by the oil in the reservoir.



Figure 3



Figure 4

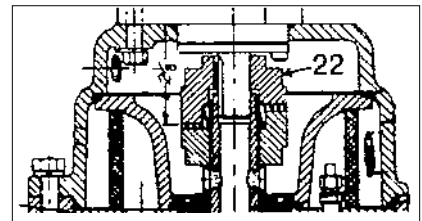

Figure 5

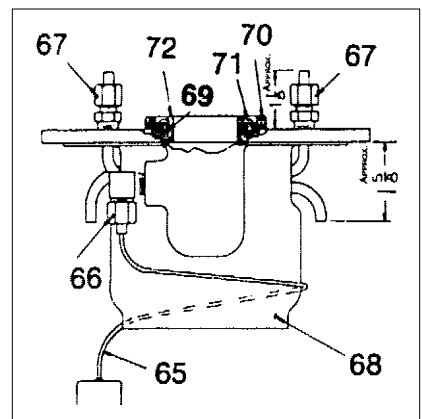

Figure 6 Spider insert.

ITEM NO.	PART NUMBER	DESCRIPTION	TOTAL RQD.
1	180-002-155	Volute Casing	1
2	258-003-010	Suction Cover	1
3	444-002-010	Impeller	1
4	612-002-080	Wear Plate	1
5	430-008-155	Motor Housing	1
6	775-002-155	Filter Spool	1
7	800-003-330	Strainer Assembly	1
8	430-007-155	Intermediate Housing	1
9	730-009-120	Shaft	1
10	430-010-150	Bearing Housing	1
11	720-002-000	Shaft Seal	1
12	070-002-000	Ball Bearing	1
13	755-001-000	Sleeve	2
14	552-001-000	Oil Seal	1
15	670-004-162	Seal Retainer	1
16	914-002-330	Governor Weight	2
17	590-002-115	Governor Pin	1
18	675-001-115	Retaining Ring	2
19	775-003-162	Governor Spool	1
20	780-002-115	Governor Spring	1
21	670-003-115	Spring Retainer	1
22	255-001-000	Coupling Assembly	1
22-1	770-013-000	Spider Insert (see Figure 6)	1
23	320-002-000	Filter Element	1
25	770-001-162	Spacer	1
26	525-003-000	Air Motor Assembly	1
Consists of:			
26-1	AD-665	Body	1
26-2	AD-666	End Plate, Drive	1
26-3	AD-651	End Plate, Dead	1
26-4	AD-652	Rotor Assembly	1
26-5	AD-691	Vane	4
26-6	AD-692	Spring, Vane	4
26-7	AD-655-A	Push Pin	2
26-8	AD-638-A	Bearing, Drive	1
26-9	AC-437	Bearing, Dead	1
26-10	AC-849	Seal, Shaft	1
26-11	AB-162	Pin, Dowel	5
26-12	AD-641-F	Gasket, End Plate	2
26-13	AD-642-A	End Cap, Dead	1
26-14	AD-643	End Cap, Dead	1
26-15	AD-644	End Cap, Gasket	1
26-16	560-003-360	O-Ring	1
27	530-001-000	Muffler Assembly	1
Consists of:			
27-1	560-199-360	O-Ring	2
27-2	538-001-555	Nipple	1
27-3	860-009-150	Tube	1
27-4	165-001-155	Cap, Upper	1
27-5	165-002-155	Cap, Lower	1
27-6	685-001-080	Rod	1
27-7	546-002-115	Cap Nut	1
27-8	901-024-180	Sealing Washer	2

Repair Parts shown in **bold face (darker)** type are more likely to need replacement after extended periods of normal use. They are readily available from most Warren Rupp distributors. The pump owner may prefer to maintain a limited inventory of these parts in his own stock to reduce repair downtime to a minimum.

IMPORTANT: When ordering repair parts always furnish pump model number, serial number and type number.

MATERIAL CODES The Last 3 Digits of Part Number

000...	Assembly, sub-assembly; and some purchased items
010...	Cast Iron
015...	Ductile Iron
080...	Carbon Steel, AISI B-1112
100...	Alloy 10
110...	Alloy Type 316 Stainless Steel
112...	Alloy "C"
114...	303 Stainless Steel
115...	302/304 Stainless Steel
117...	440-C Stainless Steel (Martensitic)
120...	416 Stainless Steel (Wrought Martensitic)
123...	410 Stainless Steel (Wrought Martensitic)
148...	Hardcoat Anodized Aluminum
149...	2024-T4 Aluminum
150...	6061-T6 Aluminum
151...	6063-T6 Aluminum
152...	2024-T4 Aluminum (2023-T351)
154...	Almag 35 Aluminum
155 or 156...	356-T6 Aluminum
157...	Die Cast Aluminum Alloy #380
159...	Anodized Aluminum
162...	Brass, Yellow, Screw Machine Stock
165...	Cast Bronze, 85-5-5-5
170...	Bronze, Bearing Type, Oil Impregnated
180...	Copper Alloy
310...	PVDF Coated
330...	Plated Steel
331...	Chrome Plated Steel
332...	Electroless Nickel Plated
335...	Galvanized Steel
354...	Injection Molded #203-40 Santoprene — Duro 40D + /-5. Color coded: RED
357...	Rupplon (Urethane Rubber) Color coded: PURPLE (Injection mold)
358...	Rupplon (Urethane Rubber) Color coded: PURPLE (Some Applications) (Compression Mold)
360...	Nitrile Rubber. Color coded: RED
363...	FKM (Fluorel). Color coded: YELLOW
364...	E.P.D.M. Rubber. Color coded: BLUE
365...	Neoprene Rubber. Color coded: GREEN
366...	Food Grade Neoprene. Color coded: GREEN
370...	Butyl Rubber. Color coded: BROWN
405...	Cellulose Fibre
408...	Cork and Neoprene
425...	Compressed Fibre
465...	Fibre
500...	Delrin 500
505...	Acrylic Resin Plastic
540...	Nylon
550...	Polyethylene
555...	PVC
570...	Rulon II
580...	Ryton
590...	Valox
591...	Nylatron G-S
592...	Nylatron NSB
600...	PTFE (virgin material) Tetrafluorocarbon (TFE)
601...	PTFE (Bronze and moly filled)
602...	Filled PTFE
603...	Blue Gylon
604...	PTFE — Diaphragm

ITEM NO.	PART NUMBER	DESCRIPTION	TOTAL RQD.
28	406-001-000	Handle Assembly	1
29	866-007-162	Male Connector	2
30	312-007-180	Elbow	1
31	200-004-330	Muffler Clamp	1
32	115-004-080	Bracket	1
33	254-004-000	Coupler	1
35	312-006-000	Elbow, Motor	1
36	312-004-162	Elbow, Motor Housing	1
37	200-005-115	Hose Clamp	2
38	427-006-000	Hose, 3/4 I.D.	1
39	675-006-000	Retaining Ring	1
40	675-005-000	Retaining Ring	1
41	675-003-080	Retaining Ring	2
42	360-004-440	Gasket	6 Minimum
43	560-013-360	O-Ring	1
44	560-007-360	O-Ring	1
45	560-012-360	O-Ring	1
46	560-009-360	O-Ring	2
47	560-006-360	O-Ring	1
48	560-008-360	O-Ring	1
49	560-005-360	O-Ring	1
51	618-005-330	Pipe Plug 1/2" NPT	1
52	312-008-335	Street Elbow	1
53	170-033-330	Capscrew	4
54	170-006-330	Capscrew	12
55	170-005-330	Capscrew	3
56	546-001-115	Cap Nut	2
57	170-002-330	Capscrew	1
58	545-003-330	Hex Nut	2
59	900-001-330	Lock Washer	5
60	901-014-180	Washer, Sealing	3
61	901-009-330	Flat Washer	2
62	900-005-330	Lock Washer	11
63	170-007-115	Capscrew	2
64	901-024-180	Sealing Washer	2
65	861-001-000	Metering Tube Assembly	1
66	312-003-000	Elbow	1
67	866-006-162	Male Connector	2
68	430-009-155	Governor Housing	1
69	560-011-360	O-Ring	1
70	670-002-162	Retainer, Seal Ring	1
71	675-004-000	Ring, Retainer	1
72	675-002-165	Seal Ring	1
73	740-002-115	Shim (.010)	3
74	740-003-115	Shim (.030)	2
75	901-005-330	Flat Washer 3/8"	4
76	170-008-115	Capscrew	10
77	860-022-180	Tubing, Soft Copper	2
78	170-063-330	Capscrew, Hex Head	1
	535-069-000	(NOT SHOWN)	1
	710-010-115	(NOT SHOWN)	4

Repair Parts shown in **bold face (darker)** type are more likely to need replacement after extended periods of normal use. They are readily available from most Warren Rupp distributors. The pump owner may prefer to maintain a limited inventory of these parts in his own stock to reduce repair downtime to a minimum.

IMPORTANT: When ordering repair parts always furnish pump model number, serial number and type number.

MATERIAL CODES

The Last 3 Digits of Part Number

000...	Assembly, sub-assembly; and some purchased items
010...	Cast Iron
015...	Ductile Iron
080...	Carbon Steel, AISI B-1112
100...	Alloy 10
110...	Alloy Type 316 Stainless Steel
112...	Alloy "C"
114...	303 Stainless Steel
115...	302/304 Stainless Steel
117...	440-C Stainless Steel (Martensitic)
120...	416 Stainless Steel (Wrought Martensitic)
123...	410 Stainless Steel (Wrought Martensitic)
148...	Hardcoat Anodized Aluminum
149...	2024-T4 Aluminum
150...	6061-T6 Aluminum
151...	6063-T6 Aluminum
152...	2024-T4 Aluminum (2023-T351)
154...	Almag 35 Aluminum
155 or 156...	356-T6 Aluminum
157...	Die Cast Aluminum Alloy #380
159...	Anodized Aluminum
162...	Brass, Yellow, Screw Machine Stock
165...	Cast Bronze, 85-5-5-5
170...	Bronze, Bearing Type, Oil Impregnated
180...	Copper Alloy
310...	PVDF Coated
330...	Plated Steel
331...	Chrome Plated Steel
332...	Electroless Nickel Plated
335...	Galvanized Steel
354...	Injection Molded #203-40 Santoprene — Durol 40D + /-5. Color coded: RED
357...	Rupplon (Urethane Rubber) Color coded: PURPLE (Injection mold)
358...	Rupplon (Urethane Rubber) Color coded: PURPLE (Some Applications) (Compression Mold)
360...	Nitrile Rubber. Color coded: RED
363...	FKM (Fluorel). Color coded: YELLOW
364...	E.P.D.M. Rubber. Color coded: BLUE
365...	Neoprene Rubber. Color coded: GREEN
366...	Food Grade Neoprene. Color coded: WHITE
370...	Butyl Rubber. Color coded: BROWN
405...	Cellulose Fibre
408...	Cork and Neoprene
425...	Compressed Fibre
465...	Fibre
500...	Delrin 500
505...	Acrylic Resin Plastic
540...	Nylon
550...	Polyethylene
555...	PVC
570...	Rulon II
580...	Ryton
590...	Valox
591...	Nylatron G-S
592...	Nylatron NSB
600...	PTFE (virgin material) Tetrafluorocarbon (TFE)
601...	PTFE (Bronze and moly filled)
602...	Filled PTFE
603...	Blue Gylon
604...	PTFE — Diaphragm

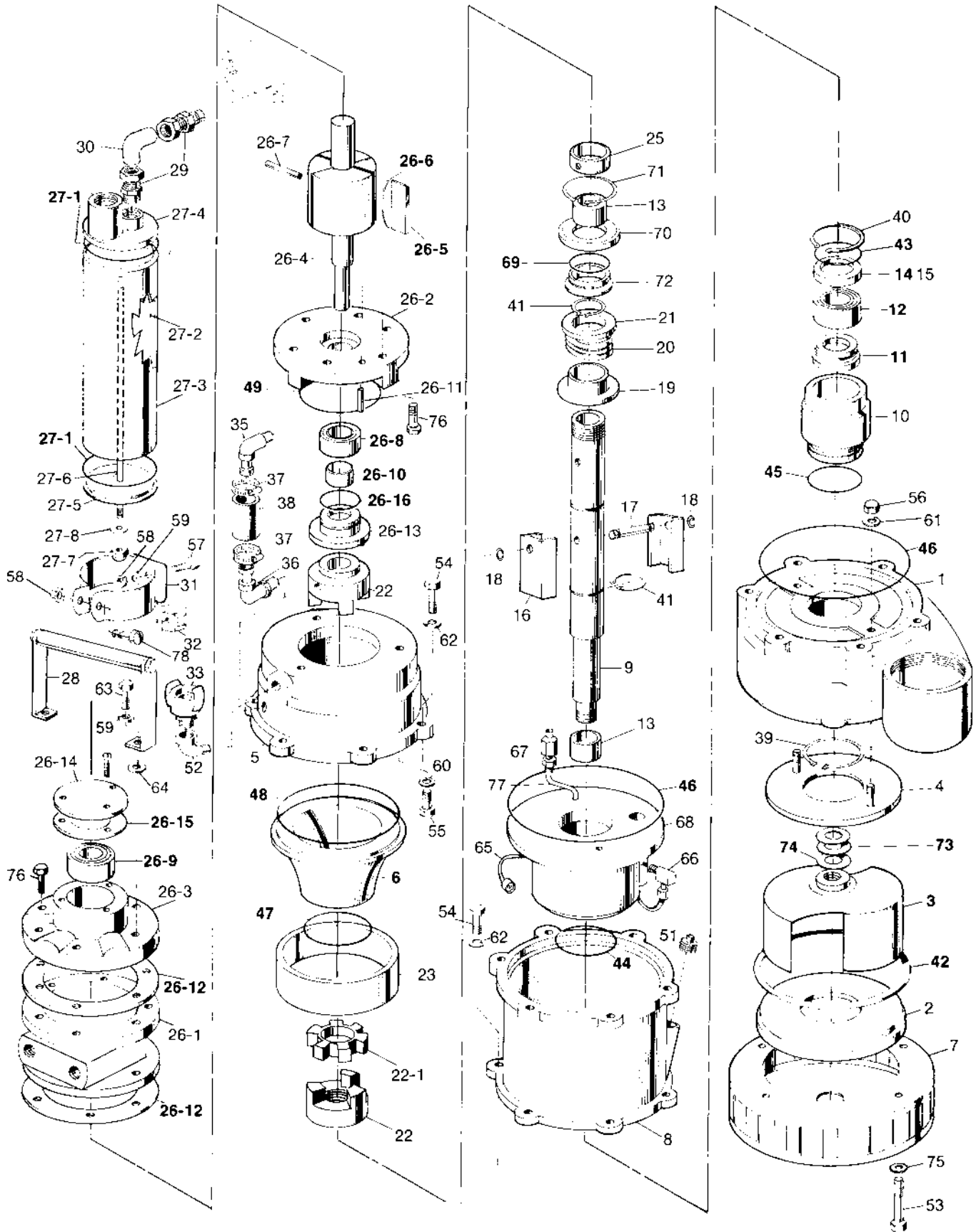

©2009 Warren Rupp, Inc. All rights reserved.
 ©SANDPIPER and Warren Rupp are registered trademarks of Warren Rupp, Inc.
 Printed in U.S.A.

1. MATERIAL AND COMPANY IDENTIFICATION

Material Name : **Warren Rupp Air Equipment Lubricant (Shell Tellus S3 M 32)**
Product Code : 001D7758
Uses : Hydraulic oil

Manufacturer/Supplier : **Shell Oil Products US**
 P.O. Box 4427
 Houston TX 77210-4427
 USA

SDS Request : (+1) 877-276-7285

Repackaged by : **Warren Rupp, Inc.**
 800 N. Main St.
 Mansfield, OH 44902
 USA

Phone : (+1) 419-524-8388

Emergency Telephone Number
Spill Information : 877-242-7400
Health Information : 877-504-9351

2. COMPOSITION/INFORMATION ON INGREDIENTS

Highly refined mineral oils and additives.
 The highly refined mineral oil contains <3% (w/w) DMSO-extract, according to IP346.

3. HAZARDS IDENTIFICATION

Emergency Overview	
Appearance and Odor	: Amber. Liquid at room temperature. Slight hydrocarbon.
Health Hazards	: High-pressure injection under the skin may cause serious damage including local necrosis.
Safety Hazards	: Not classified as flammable but will burn.
Environmental Hazards	: Not classified as dangerous for the environment.

Health Hazards : Not expected to be a health hazard when used under normal conditions.

Health Hazards

Inhalation : Under normal conditions of use, this is not expected to be a primary route of exposure.

Skin Contact : Prolonged or repeated skin contact without proper cleaning can clog the pores of the skin resulting in disorders such as oil acne/folliculitis.

Eye Contact : May cause slight irritation to eyes.

Ingestion : Low toxicity if swallowed.

Other Information : High-pressure injection under the skin may cause serious damage including local necrosis. Used oil may contain harmful impurities.

Signs and Symptoms : Oil acne/folliculitis signs and symptoms may include formation of black pustules and spots on the skin of exposed areas. Local necrosis is evidenced by delayed onset of pain and tissue

Aggravated Medical Conditions	: damage a few hours following injection. Ingestion may result in nausea, vomiting and/or diarrhea. : Pre-existing medical conditions of the following organ(s) or organ system(s) may be aggravated by exposure to this material: Skin.
Environmental Hazards	: Not classified as dangerous for the environment.
Additional Information	: Under normal conditions of use or in a foreseeable emergency, this product does not meet the definition of a hazardous chemical when evaluated according to the OSHA Hazard Communication Standard, 29 CFR 1910.1200.

4. FIRST-AID MEASURES

General Information	: Not expected to be a health hazard when used under normal conditions.
Inhalation	: No treatment necessary under normal conditions of use. If symptoms persist, obtain medical advice.
Skin Contact	: Remove contaminated clothing. Flush exposed area with water and follow by washing with soap if available. If persistent irritation occurs, obtain medical attention. When using high pressure equipment, injection of product under the skin can occur. If high pressure injuries occur, the casualty should be sent immediately to a hospital. Do not wait for symptoms to develop. Obtain medical attention even in the absence of apparent wounds.
Eye Contact	: Flush eye with copious quantities of water. If persistent irritation occurs, obtain medical attention.
Ingestion	: In general no treatment is necessary unless large quantities are swallowed, however, get medical advice.
Advice to Physician	: Treat symptomatically. High pressure injection injuries require prompt surgical intervention and possibly steroid therapy, to minimize tissue damage and loss of function. Because entry wounds are small and do not reflect the seriousness of the underlying damage, surgical exploration to determine the extent of involvement may be necessary. Local anesthetics or hot soaks should be avoided because they can contribute to swelling, vasospasm and ischemia. Prompt surgical decompression, debridement and evacuation of foreign material should be performed under general anesthetics, and wide exploration is essential.

5. FIRE-FIGHTING MEASURES

Clear fire area of all non-emergency personnel.

Flash point	: Typical 236 °C / 457 °F (COC)
Upper / lower Flammability or Explosion limits	: Typical 1 - 10 %(V)(based on mineral oil)

Auto ignition temperature	:	> 320 °C / 608 °F
Specific Hazards	:	Hazardous combustion products may include: A complex mixture of airborne solid and liquid particulates and gases (smoke). Carbon monoxide may be evolved if incomplete combustion occurs. Unidentified organic and inorganic compounds.
Suitable Extinguishing Media	:	Foam, water spray or fog. Dry chemical powder, carbon dioxide, sand or earth may be used for small fires only.
Unsuitable Extinguishing Media	:	Do not use water in a jet.
Protective Equipment for Firefighters	:	Proper protective equipment including breathing apparatus must be worn when approaching a fire in a confined space.

6. ACCIDENTAL RELEASE MEASURES

Avoid contact with spilled or released material. For guidance on selection of personal protective equipment see Chapter 8 of this Material Safety Data Sheet. See Chapter 13 for information on disposal. Observe the relevant local and international regulations.

Protective measures	:	Avoid contact with skin and eyes. Use appropriate containment to avoid environmental contamination. Prevent from spreading or entering drains, ditches or rivers by using sand, earth, or other appropriate barriers.
Clean Up Methods	:	Slippery when spilt. Avoid accidents, clean up immediately. Prevent from spreading by making a barrier with sand, earth or other containment material. Reclaim liquid directly or in an absorbent. Soak up residue with an absorbent such as clay, sand or other suitable material and dispose of properly.
Additional Advice	:	Local authorities should be advised if significant spillages cannot be contained.

7. HANDLING AND STORAGE

General Precautions	:	Use local exhaust ventilation if there is risk of inhalation of vapors, mists or aerosols. Use the information in this data sheet as input to a risk assessment of local circumstances to help determine appropriate controls for safe handling, storage and disposal of this material.
Handling	:	Avoid prolonged or repeated contact with skin. Avoid inhaling vapor and/or mists. When handling product in drums, safety footwear should be worn and proper handling equipment should be used. Properly dispose of any contaminated rags or cleaning materials in order to prevent fires.
Storage	:	Keep container tightly closed and in a cool, well-ventilated place. Use properly labelled and closeable containers. Store at ambient temperature.
Product Transfer	:	This material has the potential to be a static accumulator. Proper grounding and bonding procedures should be used during all bulk transfer operations.
Recommended Materials	:	For containers or container linings, use mild steel or high density polyethylene.
Unsuitable Materials	:	PVC.
Additional Information	:	Polyethylene containers should not be exposed to high

temperatures because of possible risk of distortion.

8. EXPOSURE CONTROLS/PERSONAL PROTECTION

Occupational Exposure Limits

Material	Source	Type	ppm	mg/m3	Notation
Oil mist, mineral	ACGIH	TWA(Inhalable fraction.)		5 mg/m3	
Oil mist, mineral	OSHA Z1	PEL(Mist.)		5 mg/m3	

Biological Exposure Index (BEI)

No biological limit allocated.

Exposure Controls

: The level of protection and types of controls necessary will vary depending upon potential exposure conditions. Select controls based on a risk assessment of local circumstances. Appropriate measures include: Adequate ventilation to control airborne concentrations. Where material is heated, sprayed or mist formed, there is greater potential for airborne concentrations to be generated. Define procedures for safe handling and maintenance of controls. Educate and train workers in the hazards and control measures relevant to normal activities associated with this product. Ensure appropriate selection, testing and maintenance of equipment used to control exposure, e.g. personal protective equipment, local exhaust ventilation. Drain down system prior to equipment break-in or maintenance. Retain drain downs in sealed storage pending disposal or for subsequent recycle. Always observe good personal hygiene measures, such as washing hands after handling the material and before eating, drinking, and/or smoking. Routinely wash work clothing and protective equipment to remove contaminants. Discard contaminated clothing and footwear that cannot be cleaned. Practice good housekeeping.

Personal Protective Equipment

: Personal protective equipment (PPE) should meet recommended national standards. Check with PPE suppliers.

- Respiratory Protection** : No respiratory protection is ordinarily required under normal conditions of use. In accordance with good industrial hygiene practices, precautions should be taken to avoid breathing of material. If engineering controls do not maintain airborne concentrations to a level which is adequate to protect worker health, select respiratory protection equipment suitable for the specific conditions of use and meeting relevant legislation. Check with respiratory protective equipment suppliers. Where air-filtering respirators are suitable, select an appropriate combination of mask and filter. Select a filter suitable for combined particulate/organic gases and vapors [boiling point >65°C (149 °F)].
- Hand Protection** : Where hand contact with the product may occur the use of gloves approved to relevant standards (e.g. Europe: EN374, US: F739) made from the following materials may provide suitable chemical protection: PVC, neoprene or nitrile rubber gloves. Suitability and durability of a glove is dependent on usage, e.g. frequency and duration of contact, chemical resistance of glove material, dexterity. Always seek advice from glove suppliers. Contaminated gloves should be replaced. Personal hygiene is a key element of effective hand care. Gloves must only be worn on clean hands. After using gloves, hands should be washed and dried thoroughly. Application of a non-perfumed moisturizer is recommended. For continuous contact we recommend gloves with breakthrough time of more than 240 minutes with preference for > 480 minutes where suitable gloves can be identified. For short-term/splash protection we recommend the same, but recognize that suitable gloves offering this level of protection may not be available and in this case a lower breakthrough time may be acceptable so long as appropriate maintenance and replacement regimes are followed. Glove thickness is not a good predictor of glove resistance to a chemical as it is dependent on the exact composition of the glove material. Glove thickness should be typically greater than 0.35 mm depending on the glove make and model.
- Eye Protection** : Wear safety glasses or full face shield if splashes are likely to occur.
- Protective Clothing** : Skin protection not ordinarily required beyond standard issue work clothes.
- Monitoring Methods** : Monitoring of the concentration of substances in the breathing zone of workers or in the general workplace may be required to confirm compliance with an OEL and adequacy of exposure controls. For some substances biological monitoring may also be appropriate. Validated exposure measurement methods should be applied by a competent person and samples analyzed by an accredited laboratory. Examples of sources of recommended exposure measurement methods are given below or contact the supplier. Further national methods may be available.

National Institute of Occupational Safety and Health (NIOSH),
USA: Manual of Analytical Methods <http://www.cdc.gov/niosh/>

Occupational Safety and Health Administration (OSHA), USA:
Sampling and Analytical Methods <http://www.osha.gov/>
Health and Safety Executive (HSE), UK: Methods for the
Determination of Hazardous Substances
<http://www.hse.gov.uk/>
Institut für Arbeitsschutz Deutschen Gesetzlichen
Unfallversicherung (IFA), Germany.
<http://www.dguv.de/inhalt/index.jsp>
L'Institut National de Recherche et de Sécurité, (INRS), France
<http://www.inrs.fr/accueil>

Environmental Exposure Controls : Take appropriate measures to fulfil the requirements of relevant environmental protection legislation. Avoid contamination of the environment by following advice given in Chapter 6. If necessary, prevent undissolved material from being discharged to waste water. Waste water should be treated in a municipal or industrial waste water treatment plant before discharge to surface water. Local guidelines on emission limits for volatile substances must be observed for the discharge of exhaust air containing vapor.

9. PHYSICAL AND CHEMICAL PROPERTIES

Appearance : Amber. Liquid at room temperature.
 Odor : Slight hydrocarbon.
 pH : Not applicable.
 Initial Boiling Point and Boiling Range : > 280 °C / 536 °F estimated value(s)
 Pour point : Typical -30 °C / -22 °F
 Flash point : Typical 236 °C / 457 °F (COC)
 Upper / lower Flammability or Explosion limits : Typical 1 - 10 % (V) (based on mineral oil)
 Auto-ignition temperature : > 320 °C / 608 °F
 Vapor pressure : < 0.5 Pa at 20 °C / 68 °F (estimated value(s))
 Specific gravity : Typical 0.860 at 15 °C / 59 °F

Density : Typical 860 kg/m³ at 15 °C / 59 °F
 Water solubility : Negligible.
 n-octanol/water partition coefficient (log Pow) : > 6 (based on information on similar products)
 Kinematic viscosity : Typical 32 mm²/s at 40 °C / 104 °F
 Vapor density (air=1) : > 1 (estimated value(s))
 Electrical conductivity : This material is not expected to be a static accumulator.
 Evaporation rate (nBuAc=1) : Data not available

10. STABILITY AND REACTIVITY

Stability : Stable.
Conditions to Avoid : Extremes of temperature and direct sunlight.
Materials to Avoid : Strong oxidizing agents.
Hazardous Decomposition Products : Hazardous decomposition products are not expected to form during normal storage.

11. TOXICOLOGICAL INFORMATION

- Basis for Assessment** : Information given is based on data on the components and the toxicology of similar products.
Unless indicated otherwise, the data presented is representative of the product as a whole, rather than for individual component(s).
- Acute Oral Toxicity** : Expected to be of low toxicity: LD50 > 5000 mg/kg , Rat
- Acute Dermal Toxicity** : Expected to be of low toxicity: LD50 > 5000 mg/kg , Rabbit
- Acute Inhalation Toxicity** : Not considered to be an inhalation hazard under normal conditions of use.
- Skin Irritation** : Expected to be slightly irritating. Prolonged or repeated skin contact without proper cleaning can clog the pores of the skin resulting in disorders such as oil acne/folliculitis.
- Eye Irritation** : Expected to be slightly irritating.
- Respiratory Irritation** : Inhalation of vapors or mists may cause irritation.
- Sensitization** : Not expected to be a skin sensitizer.
- Repeated Dose Toxicity** : Not expected to be a hazard.
- Mutagenicity** : Not considered a mutagenic hazard.
- Carcinogenicity** : Not expected to be carcinogenic. Product contains mineral oils of types shown to be non-carcinogenic in animal skin-painting studies. Highly refined mineral oils are not classified as carcinogenic by the International Agency for Research on Cancer (IARC).

Material	Carcinogenicity Classification
Highly refined mineral oil (IP346 <3%)	ACGIH Group A4: Not classifiable as a human carcinogen.
Highly refined mineral oil (IP346 <3%)	IARC 3: Not classifiable as to carcinogenicity to humans.
Highly refined mineral oil (IP346 <3%)	GHS / CLP: No carcinogenicity classification

- Reproductive and Developmental Toxicity** : Not expected to be a hazard.

Additional Information : Used oils may contain harmful impurities that have accumulated during use. The concentration of such impurities will depend on use and they may present risks to health and the environment on disposal. ALL used oil should be handled with caution and skin contact avoided as far as possible. High pressure injection of product into the skin may lead to local necrosis if the product is not surgically removed.

12. ECOLOGICAL INFORMATION

Eco toxicological data have not been determined specifically for this product. Information given is based on knowledge of the components and the ecotoxicology of similar products. Unless indicated otherwise, the data presented is representative of the product as a whole, rather than for individual component(s).

Acute Toxicity : Poorly soluble mixture. May cause physical fouling of aquatic organisms. Expected to be practically nontoxic: LL/EL/IL50 > 100 mg/l (to aquatic organisms) LL/EL50 expressed as the nominal amount of product required to prepare aqueous test extract. Mineral oil is not expected to cause any chronic effects to aquatic organisms at concentrations less than 1 mg/l.

Mobility : Liquid under most environmental conditions. If it enters soil, it will adsorb to soil particles and will not be mobile. Floats on water.

Persistence/degradability : Expected to be not readily biodegradable. Major constituents are expected to be inherently biodegradable, but the product contains components that may persist in the environment.

Bioaccumulation : Contains components with the potential to bioaccumulate.

Other Adverse Effects : Product is a mixture of non-volatile components, which are not expected to be released to air in any significant quantities. Not expected to have ozone depletion potential, photochemical ozone creation potential or global warming potential.

13. DISPOSAL CONSIDERATIONS

Material Disposal : Recover or recycle if possible. It is the responsibility of the waste generator to determine the toxicity and physical properties of the material generated to determine the proper waste classification and disposal methods in compliance with applicable regulations. Do not dispose into the environment, in drains or in water courses.

Container Disposal : Dispose in accordance with prevailing regulations, preferably to a recognized collector or contractor. The competence of the collector or contractor should be established beforehand.

Local Legislation : Disposal should be in accordance with applicable regional, national, and local laws and regulations.

14. TRANSPORT INFORMATION

US Department of Transportation Classification (49CFR)

This material is not subject to DOT regulations under 49 CFR Parts 171-180.

IMDG

This material is not classified as dangerous under IMDG regulations.

IATA (Country variations may apply)

This material is either not classified as dangerous under IATA regulations or needs to follow country specific requirements.

15. REGULATORY INFORMATION

The regulatory information is not intended to be comprehensive. Other regulations may apply to this material.

Federal Regulatory Status

Notification Status

EINECS	All components listed or polymer exempt.
TSCA	All components listed.
DSL	All components listed.

Shell classifies this material as an "oil" under the CERCLA Petroleum Exclusion, therefore releases to the environment are not reportable under CERCLA.

State Regulatory Status

California Safe Drinking Water and Toxic Enforcement Act (Proposition 65)

This material does not contain any chemicals known to the State of California to cause cancer, birth defects or other reproductive harm.

16. OTHER INFORMATION

NFPA Rating (Health, Fire, Reactivity)	: 0, 1, 0
SDS Version Number	: 1.1
SDS Effective Date	: 02/05/2014
SDS Revisions	: A vertical bar () in the left margin indicates an amendment from the previous version.
SDS Regulation	: The content and format of this MSDS is in accordance with the OSHA Hazard Communication Standard, 29 CFR 1910.1200.
SDS Distribution	: The information in this document should be made available to

all who may handle the product.

Disclaimer

: The information contained herein is based on our current knowledge of the underlying data and is intended to describe the product for the purpose of health, safety and environmental requirements only. No warranty or guarantee is expressed or implied regarding the accuracy of these data or the results to be obtained from the use of the product.