

2" NON-METALLIC FLAP VALVE

MINING INDUSTRY

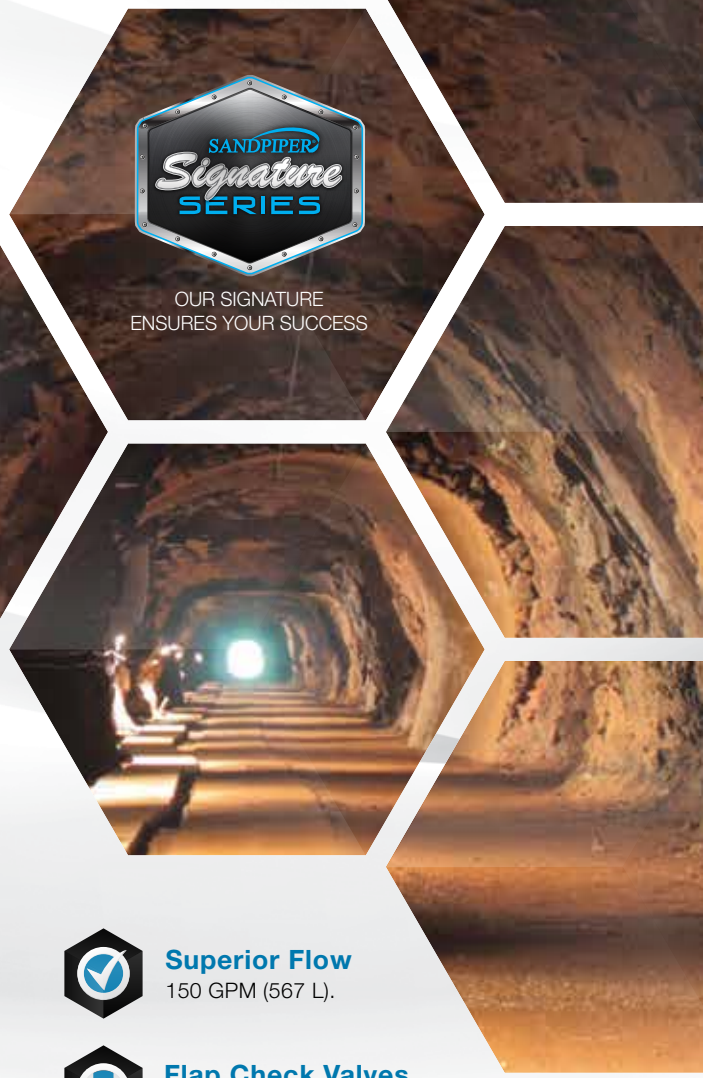

OUR SIGNATURE
ENSURES YOUR SUCCESS

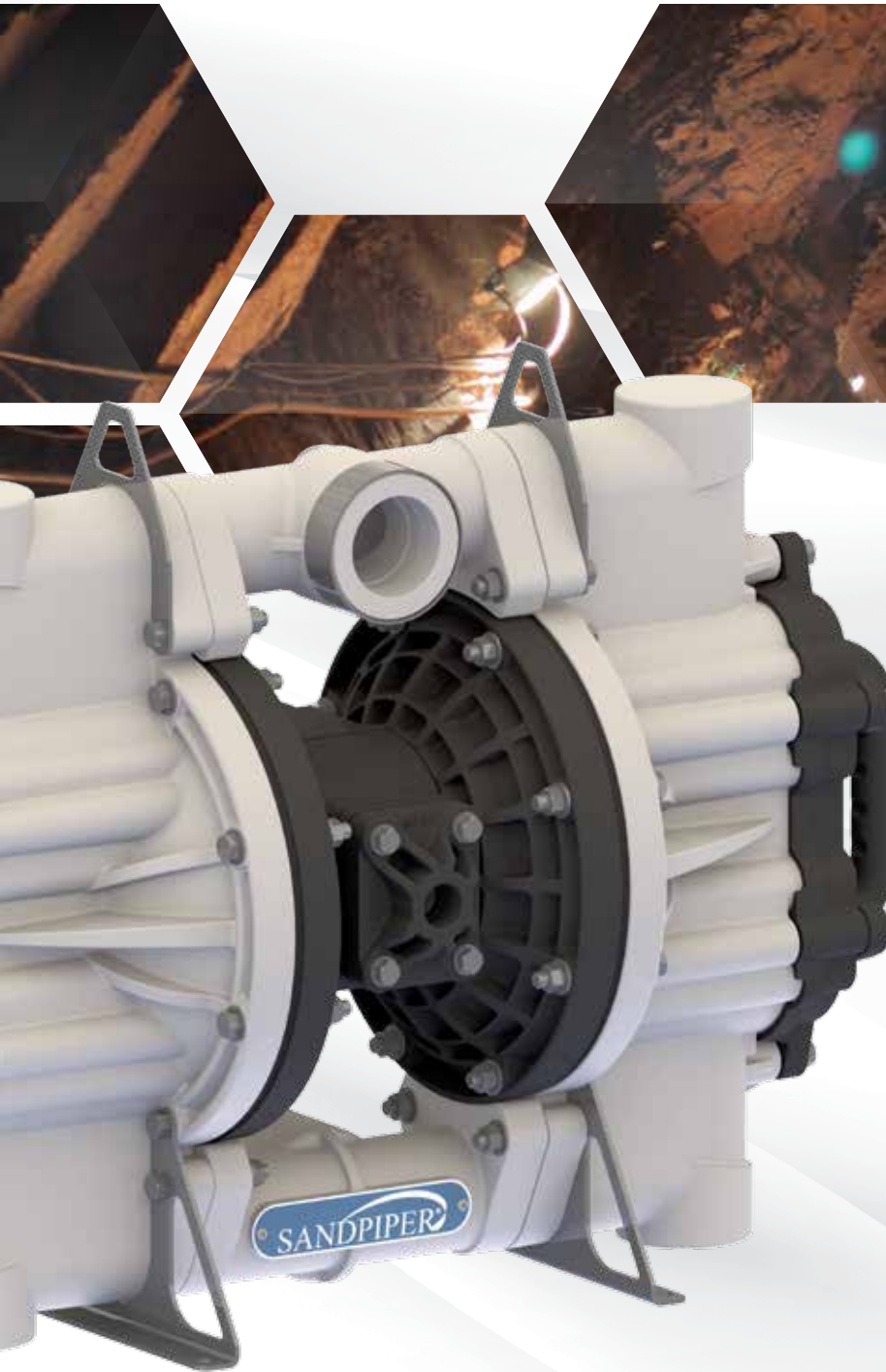

Superior Flow

150 GPM (567 L).



Flap Check Valves

Performance & solids handling.



Porting Options

Optional flanged or threaded connection



Lightweight & Portable

Weighs in at 53 lbs (24 kg).



ESADS+Plus Air Valve

Externally Serviceable Air Distribution System.



Robust Air Valve Design

Mine proven stainless sleeve / brass spool air valve available. Being free of dynamic seals helps it to tolerate even the dirtiest of air.



IBEX

SANDPIPER
A WARREN RUPP INC. BRAND

SANDPIPERPUMP.COM/HDF2NMMINE

REDEFINING THE FL

YOUR MINING INDUSTRY SOLUTION

The robust, yet lightweight design allows for ease of maintenance and movement, and is ideal for handling solids and corrosive fluids. This unique mining pump has been engineered to fully function in any position, includes lifting handles and hanging points, and has durable mounting feet. This is an ideal solution for mining applications.



Lightweight & Durable

The non-metallic, lightweight design makes it easily portable at 53 lbs (24 kg).



Reliability Guarantee

Strongest diaphragm connecting rod in the industry is guaranteed to not bend or yield in operation.



Rugged Design

Stainless steel seats prevent abrasion when pumping solids laden fluids.



Optimum Solids Handling

Hinge pads exert positive pressure on the flaps, allowing the pump to operate in virtually any position. They help deliver superior suction lift and flow rates.



Long Life

A proven diaphragm design in conjunction with exclusive wear pads reduce plate abrasion, delivering extended life.



Purpose Built Base

The threaded version features stainless steel mounting feet and the flanged version features Polypropylene mounting feet

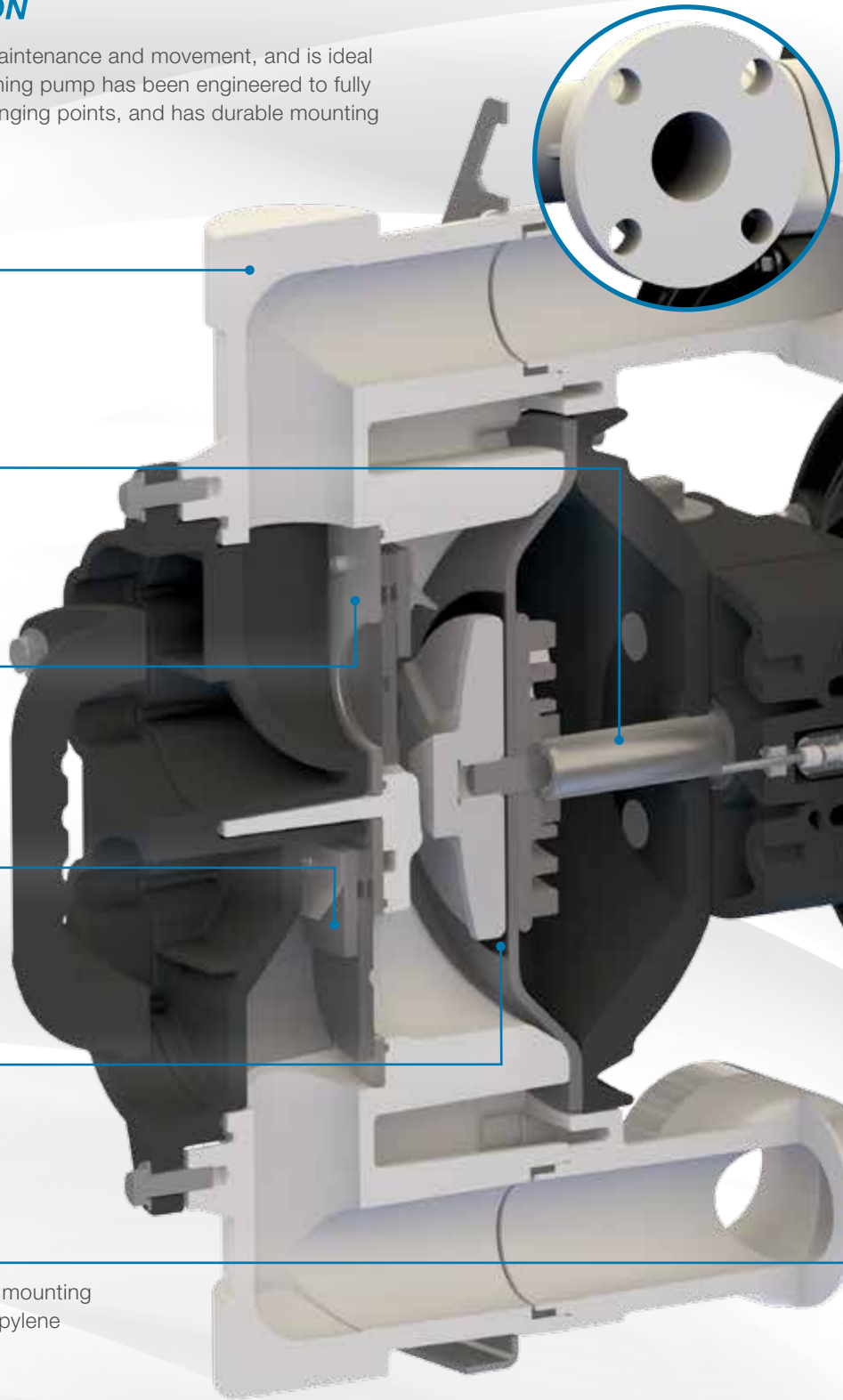

FLAP VALVE PUMP

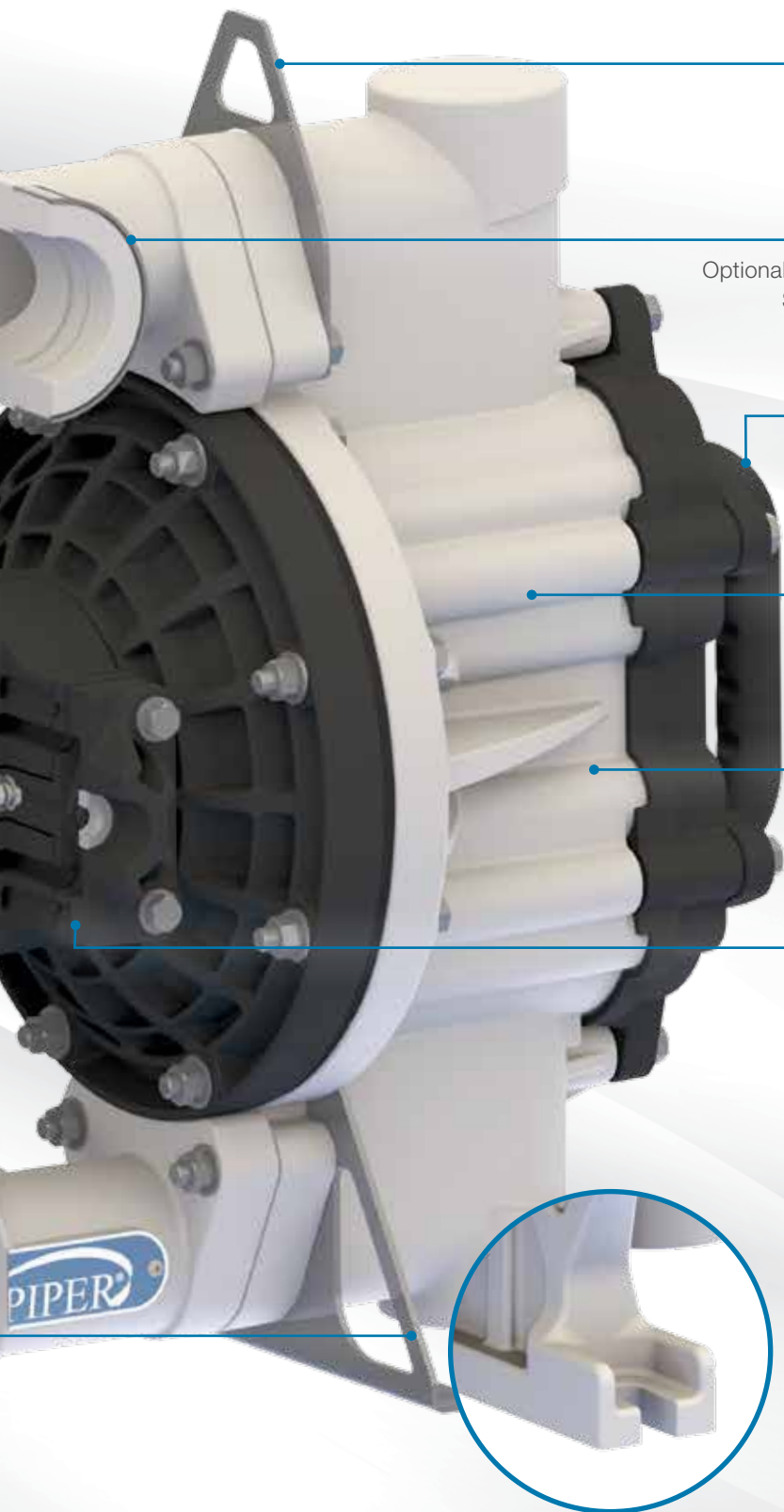

Industrial Mounting Capabilities

Addition of stainless steel hanging points located on the manifold allow for multiple mounting options.



Strong Manifold Connections

Optional flanged or threaded connection for additional flexibility: Stainless steel reinforcing rings help protect the threaded manifold connections from being damaged.



Ergonomic Handle

Lifting handles come standard, allowing for easy pump transport. Handles can be rotated 90 degrees for proper ergonomics, depending on desired use.



Unsurpassed Performance

Industry leading flow rates, suction lift, air efficiency and displacement per stroke.



Versatile Design

This pump will function in any position, including uneven surfaces.



Simple Maintenance

With our signature ESADS+Plus (Externally Serviceable Air Distribution System) air valve design and externally serviceable flap valve modules, in-field service is quick and easy, saving you from unnecessary downtime.



Visit SANDPIPERPUMP.COM/ESADSVideos to see how easy the ESADS air valve makes maintaining the 2" Non-Metallic Flap Valve.

PERFORMANCE & DIMENSIONS

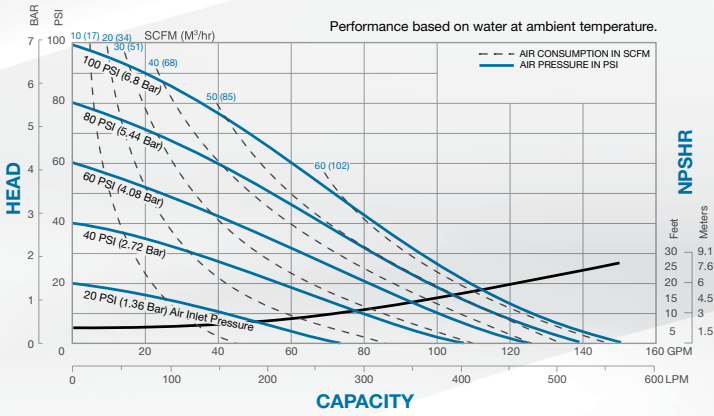

Max Capacity

150 GPM (567 L)

Displacement Per Stroke

.50 Gal (1.9 L)

Max Discharge Pressure

100 PSI (7.0 BAR)

Pipe Size

2" NPT / BSP / ANSI / DIN Flange

Max Solids Handling

1.8" (46mm)

Air End/Wet End

Polypropylene / Stainless Steel Seats (Wet End Only)

HD20F Non-Metallic

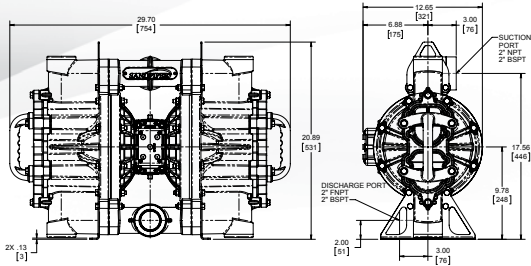

HD20F Non-Metallic Flanged Manifold

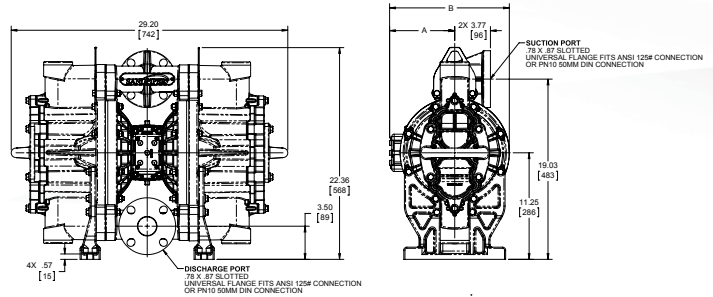

EASE OF MAINTENANCE

To help increase productivity and reduce downtime, the 2" Non-Metallic Flap Valve Pump was engineered with ease of maintenance in mind.

QUICK ACCESS TO SERVICEABLE COMPONENTS

1. Remove Clean-Out Cap

By simply removing six bolts securing the clean-out cap in place, it allows access to clear simple clogs without disassembling the entire pump

2. Modular Check Valve Access

With the clean-out cap removed, the flap valves can be inspected and / or replaced as needed; four bolts hold the modular flap valves in place for quick maintenance and repair

3. ESADS+Plus

Proven air distribution system allows for maintenance and / or repair of both pilot valve and air valve components without removing the pump from service

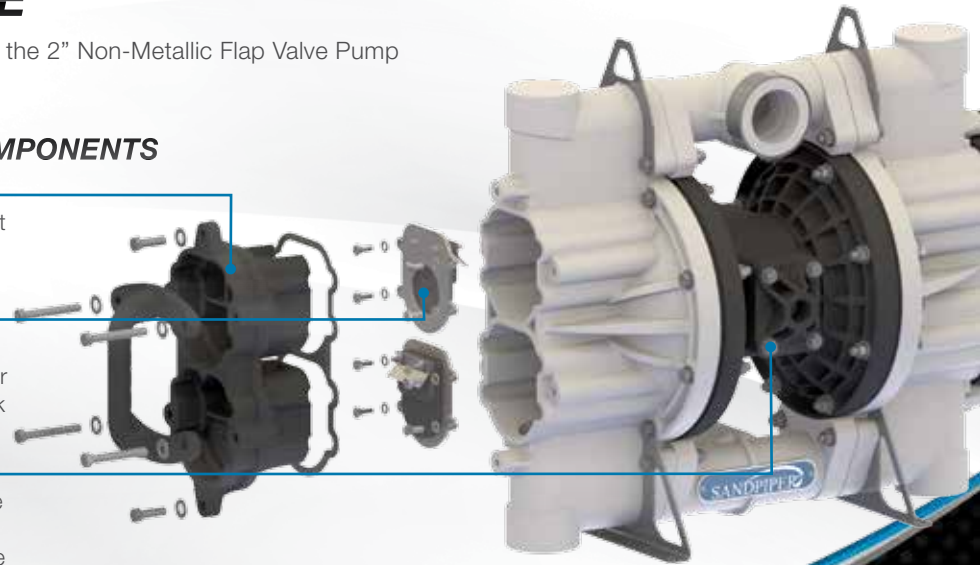

SANDPIPER
A WARREN RUPP, INC. BRAND

Warren Rupp, Inc.
A Unit of IDEX Corporation
800 North Main Street
Mansfield, OH 44902 USA

Phone: 419.524.8388

Fax: 419.522.7867

SANDPIPERPUMP.COM



Contact Your Local Distributor to Place Your Order:

