



SANDPIPER® 

SERVAES



EPC DATA SUBMITTAL PACK

Customizable Pump Data Sheet for RFQ (with limited scope of supply)
Specifications and Performance Data Sheet

Requester's LOGO	NATURAL GAS OPERATED DOUBLE DIAPHRAGM PUMP DATA SHEET						Document No. _____ Revision No. _____ Item No. _____	C h a n g e s
For: Proposal <input type="checkbox"/>		Purchase <input type="checkbox"/>	As Built <input type="checkbox"/>					
1	Contract No.							
2	Purch Order							
3	Tag/Item No.							
4	Client Name:							
5	Location:							
6	Service Area:	Hazardous Area Classification: Zone _____ Group _____ Class _____			Other:	Unclassified (non-Hazardous) <input type="checkbox"/>		
7	Applicable Standards:							
8	Manufacturer:	Quantity:	Pumps in Operation:	Spare(s):				
9	Pump Size :							
CONSTRUCTION				OPERATING CONDITIONS & LIQUID CHARACTERISTICS (for each pump)				
10	Liquid End:			Service / Duty (Intermittent/Continuous)				
11	Gas End (Center Section):			Fluid Pumped:				
12	Connections:	Size	ANSI Rating	Face	Type	Position	Corrosion/Erosive Due To:	
13	Suction:					Top	Liquid Temperature (PT):	°F / °C
14	Discharge:					Bottom	Ambient Temperature:	°F / °C
15	Gas Inlet:					N/A	Specific Gravity @Duty PT:	
16	Hydrotest Pressure:	500 psig			Viscosity @Duty PT:		cps	
17	No. of Diaphragm Chambers:	2			Vap. Pressure @Duty PT		psia/bara	
18	Inlet and Outlet Valve Type:			Discharge Pressure		psig/barg		
19	Pump Type:			Suction Pressure		psig/barg		
20				Capacity @ PT:		gpm / m3/hr		
21				Gas Supply Pressure:		psig/barg		
22				Gas Supply Pressure:		psig/barg		
23				NPSH Available		FT/M		
24				H ₂ S Concentration		ppvm		
25				Solids		Size / % Conc		
MATERIALS				PERFORMANCE				
26	Diaphragms:			Rated Capacity (GPM/M3/Hr):				
27	Check Valve Balls/Flaps:			NPSH Required (FT/M):				
28	Check Valve Seats:			Max Gas Consumption: (scfm / m3/hr)				
29	Gas Valve O'rings:			Max Gas Inlet Pressure :(psig/barg)				
30	Gas Valve Gaskets			Max Discharge Pressure: (psig/barg)				
31	Suction Manifold			LAB TEST		REQUIRED	WITNESSED	
32	Discharge Manifold			Hydrostatic Test:				
33	Inlet Gas Inlet Valve			Performance Test:				
34	Inlet Gas Regulator (Max 100 psig)			Snoop Test: (see line 57 below)				
35	Inlet Gas Filter			Other:				
36				Other:				
37				Other:				
SCOPE OF SUPPLY								
38	Pump Type/Design:							
39	Compressed natural gas powered, double diaphragm pump							
40	Bolted fluid and gas housing connections							
41	NPT threaded or ANSI flanged process fluid connections							
42	Main gas valve and pilot valve to be repairable or replaceable without disconnecting process fluid connections or disassembling fluid housings							
43	Natural gas exhaust to be a single connection							
44	Materials of Construction:							
45	Aluminum or stainless steel gas housings							
46	Aluminum or stainless steel liquid housings							
47	Nitrile or PTFE diaphragms							
48	Nitrile or PTFE check balls							
49	Nitrile or Viton gas end seals							
50	Diaphragm connecting rod to be 416 stainless steel or 316 stainless steel							
51	Certifications:							
52	CSA certified to ANSI LC6-2008 Natural Gas Operated Diaphragm Pumps (USA)							
53	CSA certified to Technical Information Letter No. R-14 Natural Gas Operated Diaphragm Pumps (Canada)							
54	Meets NACE MR0175/ISO 15156 Material Recommendations							
55	ATEX Certified: Group II, Category 2 (Aluminum gas or fluid housings); Group II, Category 1 (Stainless steel gas and fluid housings)							
56	Manufacturing and Production Tests:							
57	100% testing of gas-containing housings - pumps shall not leak externally at a rate in excess of 200 cm ³ per hour at 150 PSI test pressure							
58	All parts of the pump subjected to pressure, except the pumping diaphragms, shall withstand a hydrostatic test of 5 times the maximum rated operating pressure							
59	Resistance to static electric charge; dissipation shall not exceed one mega-ohm between the grounding connection and each metal component							
60	Temperature Limits:							
61	Minimum: -10°F (-23°C)							
62	Maximum: 180°F (82°C)							
REMARKS								
63								
64								
65								
66								
67								
68								

DATA SHEET

Specifications & Performance

Certified Quality



Quality System
ISO9001 Certified



Environmental Management System
ISO14001 Certified



Certified to CSA Technical Letter No, R-14



Certified to ANSI LC6-2008

Warren Rupp, Inc.

A Unit of IDEX Corporation

800 N. Main St.,

Mansfield, Ohio 44902 USA

Telephone 419.524.8388

Fax 419.522.7867

WWW.SANDPIPERPUMP.COM



© Copyright 2013 Warren Rupp, Inc.
All rights reserved

Model G15

Metallic Design Level 1

Natural Gas-Operated Diaphragm Pumps

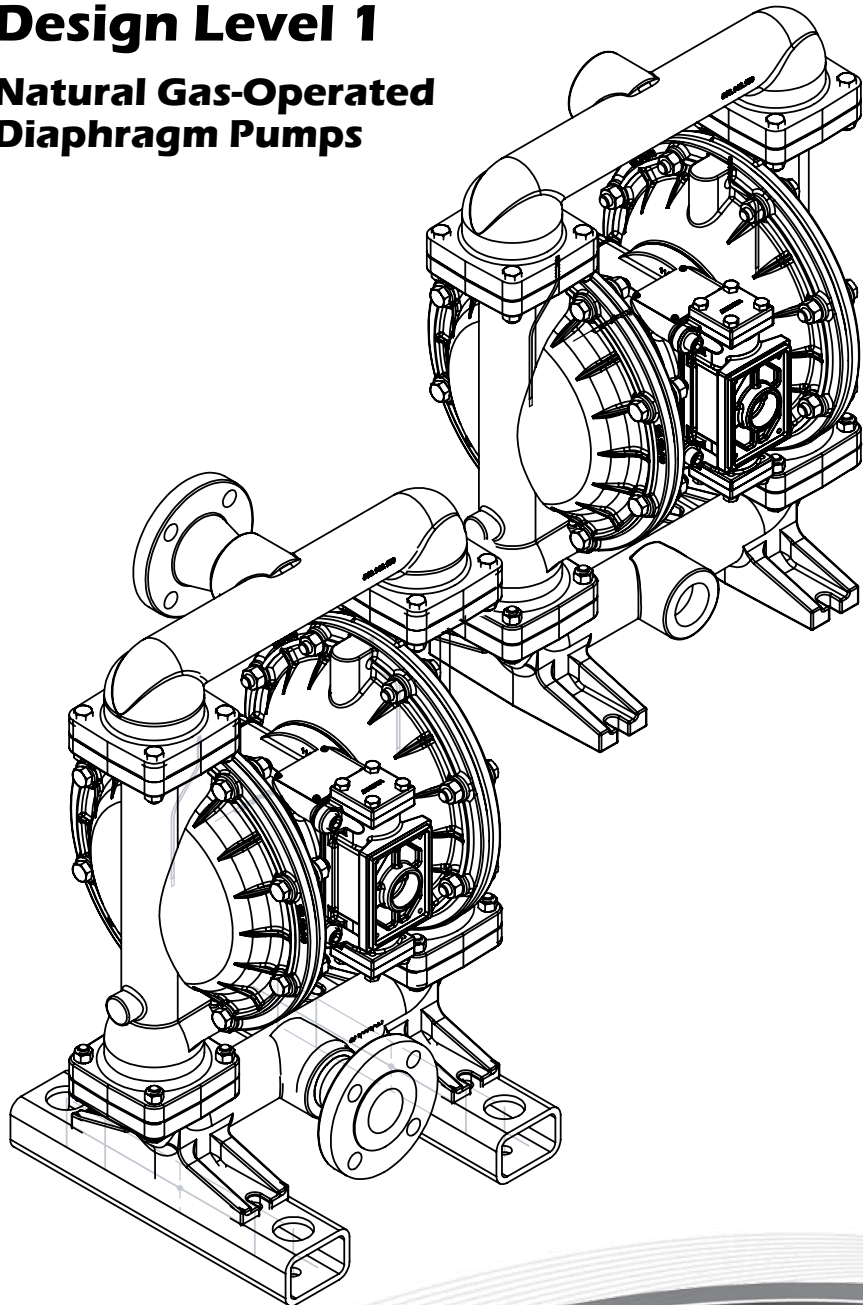

SANDPIPER[®]
A WARREN RUPP, INC. BRAND

WWW.SANDPIPERPUMP.COM

Explanation of Pump Nomenclature

Your Model #: **G**

(fill in from pump nameplate)

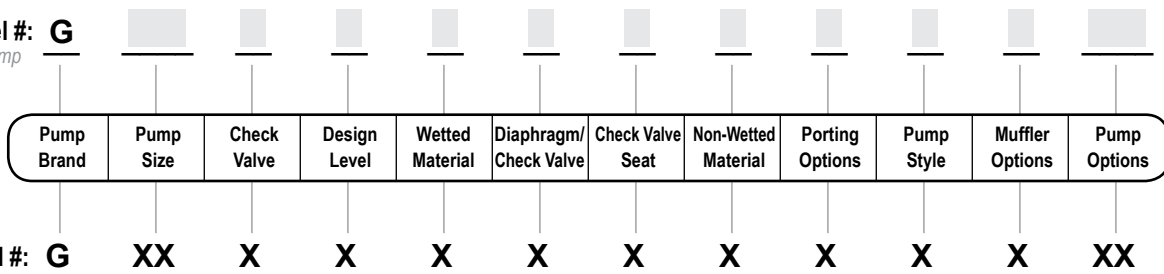

Pump Brand

G Natural Gas Operated

Pump Size

15 1½"

Check Valve Type

B Ball

Design Level

1 Design Level

Wetted Material

S Stainless Steel

A Aluminum

Diaphragm/Check Valve Materials

B Nitrile/Nitrile

T PTFE -Nitrile/PTFE

5 Nitrile/PTFE

Check Valve Seat

T PTFE

S Stainless Steel

A Aluminum

Non-Wetted Material Options

A Painted Aluminum

B Unpainted Aluminum with Stainless Steel Gas Valve

D Unpainted Aluminum with Stainless Steel Gas Valve with FKM O-rings

X Unpainted Aluminum

0 Unpainted Aluminum/FKM Elastomers

V Unpainted Aluminum/FKM Elastomers

S Stainless Steel/ S02/304 SS Hardware

T Stainless Steel/ 316 Stainless Hardware

7 Painted Stainless Steel

8 Stainless Steel/FKM Elastomers

9 Painted Stainless Steel/FKM Elastomers

Porting Options

N NPT Threads

B BSP (Tapered) Threads

R 150# Raised Face 1 1/2" ANSI Flange w/ Threaded Pipe Connections

W 150# Welded Raised Face 1 1/2" ANSI Flanged Manifolds

Pump Style

S Standard

Muffler Options

X No Muffler *

Your Serial #: (fill in from pump nameplate) _____

ATEX Detail

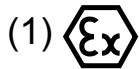

II 1G c T5
II 3/1 G c T5
II 1D c T100°C †
I M1 c
I M2 c

Models equipped with Wetted Option S Non-Wetted Options S, T, 7, 8, or 9, Pump Option X.

Note: See ATEX Explanation of EC-Type Certificate

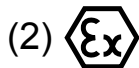

II 2G c T5
II 3/2 G c T5
II 2D c T100°C †

Models equipped with Wetted Options A or S, All Non-Wetted Options, Pump Option X.

Note: See ATEX Explanation of Type Examination Certificate

Performance

G15 METALLIC

SUCTION/DISCHARGE PORT SIZE

- 1½"

CAPACITY

- 0 to 106 gallons per minute
(0 to 401 liters per minute)

GAS DISTRIBUTION VALVE

- No-lube, no-stall design

SOLIDS-HANDLING

- Up to .25 in. (6mm)

HEADS UP TO

- 100 psi or 231 ft. of water
(7 bar or 70 meters)

MAXIMUM OPERATING PRESSURE

- 100 psi (7 bar)

DISPLACEMENT/STROKE

- .41 Gallon / 1.55 liter

SHIPPING WEIGHT

- Aluminum 53 lbs. (24kg)
- Stainless Steel 95 lbs. (43kg)

These pump models are designed to pump the following fluids:
Crude Oil, Salt Water, Drilling Mud, Condensate, Lubrication Oils,
Glycol, Caustic Liquids, and Acids."

MODEL G15 Metallic Performance Curve

Performance based on the following: elastomer fitted pump, flooded suction, water at ambient conditions.
The use of other materials and varying hydraulic conditions may result in deviations in excess of 5%.

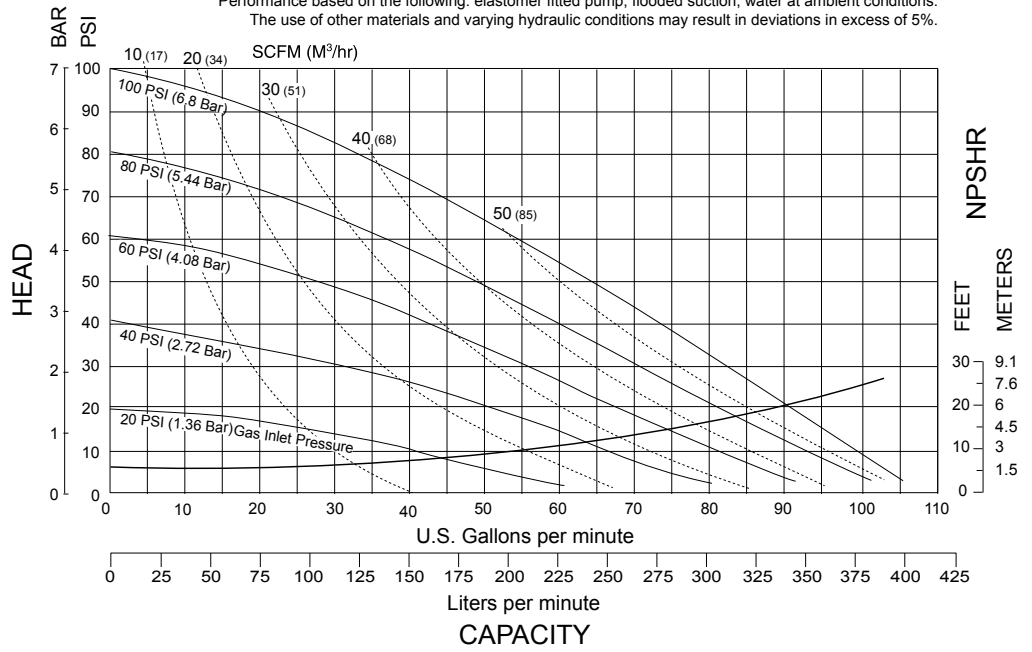

Exhaust Gas: The exhausted natural gas must be vented to a low pressure safe location in accordance with local fire safety and environmental codes, or in the absence of local codes, an industry or nationally recognized code having jurisdiction over the specific installations, and/or CAN/CGA B149, Installation Codes

Materials

Material Profile:

CAUTION! Operating temperature limitations are as follows:

FKM: (Fluorocarbon) Shows good resistance to a wide range of oils and solvents; especially all aliphatic, aromatic and halogenated hydrocarbons, acids, animal and vegetable oils. Hot water or hot aqueous solutions (over 70°F(21°C)) will attack FKM.

Nitrile: General purpose, oil-resistant. Shows good solvent, oil, water and hydraulic fluid resistance. Should not be used with highly polar solvents like acetone and MEK, ozone, chlorinated hydrocarbons and nitro hydrocarbons.

Virgin PTFE: (PFA/TFE) Chemically inert, virtually impervious. Very few chemicals are known to chemically react with PTFE; molten alkali metals, turbulent liquid or gaseous fluorine and a few fluoro-chemicals such as chlorine trifluoride or oxygen difluoride which readily liberate free fluorine at elevated temperatures.

Maximum and Minimum Temperatures are the limits for which these materials can be operated. Temperatures coupled with pressure affect the longevity of diaphragm pump components. Maximum life should not be expected at the extreme limits of the temperature ranges.

Metals:

Stainless Steel: Equal to or exceeding ASTM specification A743 CF-8M for corrosion resistant iron chromium, iron chromium nickel and nickel based alloy castings for general applications. Commonly referred to as 316 Stainless Steel in the pump industry.

For specific applications, always consult the Chemical Resistance Chart.

Ambient temperature range: -20°C to +40°C

Process temperature range: -20°C to +80°C for models rated as category 1 equipment
-20°C to +100°C for models rated as category 2 equipment

In addition, the ambient temperature range and the process temperature range do not exceed the operating temperature range of the applied non-metallic parts as listed in the manuals of the pumps.

Dimensional Drawings

G15 Metallic - NPT

Dimensions in inches (mm dimensions in brackets). Dimensional Tolerance: $\pm 1/8"$ ($\pm 3\text{mm}$)

The dimensions on this drawing are for reference only. A certified drawing can be requested if physical dimensions are needed.

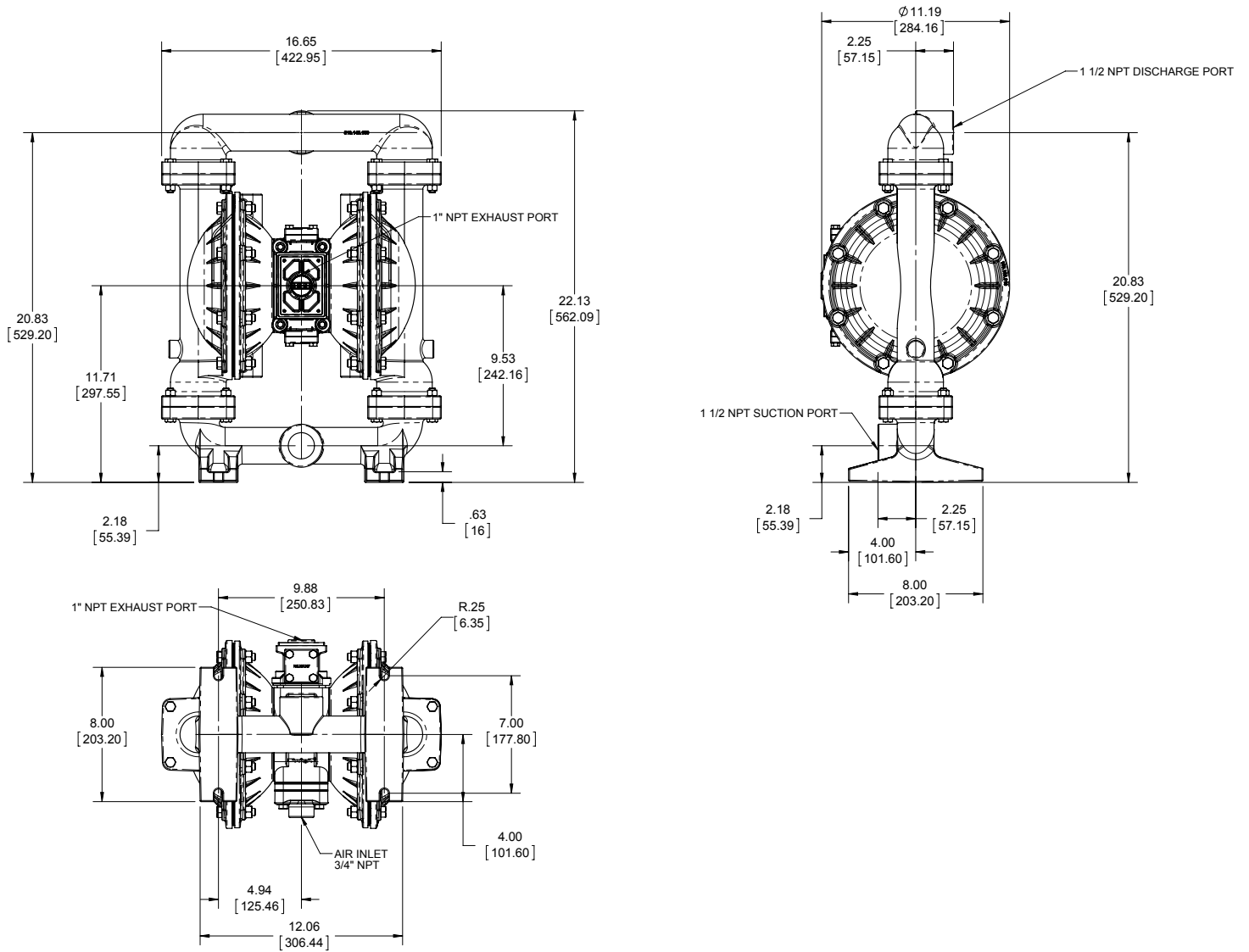

Dimensional Drawings

G15 Metallic - ANSI Flange

Dimensions in inches (mm dimensions in brackets). Dimensional Tolerance: $\pm 1/8"$ ($\pm 3\text{mm}$)

The dimensions on this drawing are for reference only. A certified drawing can be requested if physical dimensions are needed.

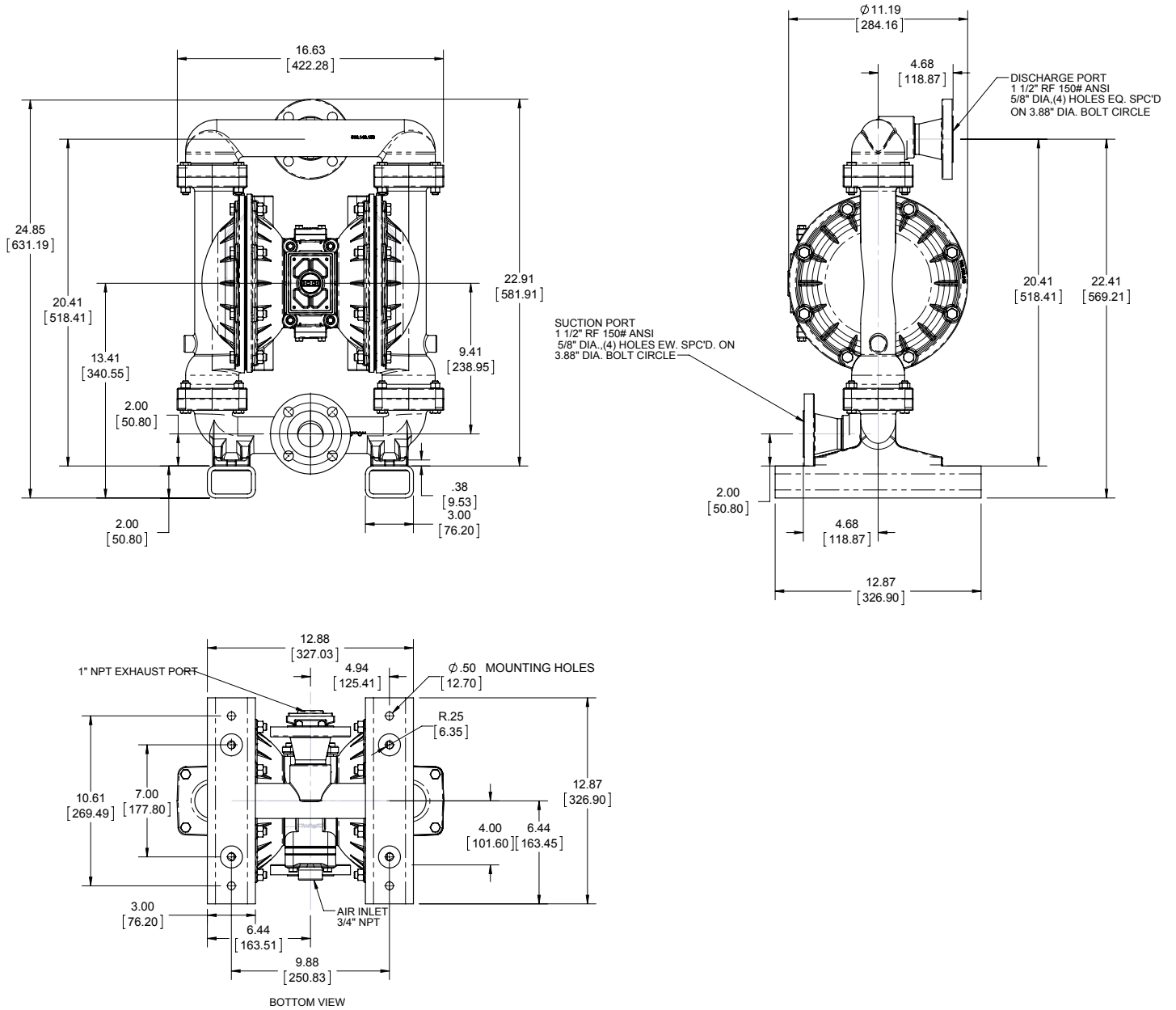

Written Warranty

5 - YEAR Limited Product Warranty

Quality System ISO9001 Certified • Environmental Management Systems ISO14001 Certified

Warren Rupp, Inc. ("Warren Rupp") warrants to the original end-use purchaser that no product sold by Warren Rupp that bears a Warren Rupp brand shall fail under normal use and service due to a defect in material or workmanship within five years from the date of shipment from Warren Rupp's factory. Warren Rupp brands include SANDPIPER®, MARATHON®, PortaPump®, SludgeMaster™ and Tranquilizer®.

~ See complete warranty at www.sandpiperpump.com/About/guaranteesandwarranties.html ~

**WARREN
RUPP, INC.®**

Declaration of Conformity

**Manufacturer: Warren Rupp, Inc.®, 800 N. Main Street, P.O. Box 1568,
Mansfield, Ohio, 44901-1568 USA**

Certifies that Air-Operated Double Diaphragm Pump Series: HDB, HDF, M Non-Metallic, S Non-Metallic, M Metallic, S Metallic, T Series, G Series, U Series, EH and SH High Pressure, RS Series, W Series, SMA and SPA Submersibles, and Tranquilizer Surge Suppressors comply with the European Community Directive 2006/42/EC on Machinery, according to Annex VIII. This product has used Harmonized Standard EN809:1998+A1:2009, Pumps and Pump Units for Liquids - Common Safety Requirements, to verify conformance.

David Roseberry
Signature of authorized person

David Roseberry
Printed name of authorized person

Revision Level: F

October 20, 2005
Date of issue

Engineering Manager
Title

August 23, 2012
Date of revision

IDEX
CORPORATION



WARREN RUPP, INC.®

EC Declaration of Conformity

In accordance with ATEX Directive 94/9/EC,
Equipment intended for use in potentially explosive environments.

Manufacturer: Warren Rupp, Inc.®, A Unit of IDEX Corporation
800 North Main Street, P.O. Box 1568, Mansfield, OH 44901-1568 USA

EN 60079-25: 2004

For pumps equipped with Pulse Output ATEX Option
KEMA Quality B.V. (0344)

Applicable Standard:
EN13463-1: 2001,
EN13463-5: 2003



AODD Pumps and Surge Suppressors

For Type Examination Designations

AODD (Air-Operated Double Diaphragm) Pumps

EC Type Examination Certificate No. Pumps: KEMA 09ATEX0071 X
KEMA Quality B.V.
Utrechtseweg 310
6812 AR Arnhem, The Netherlands

SANDPIPER®
A WARREN RUPP, INC. BRAND

Tranquilizer®



DATE/APPROVAL/TITLE:
27 MAY 2010

David Roseberry
David Roseberry, Engineering Manager

ATEX Summary of Markings

Type	Marking	Listed In	Non-Conductive Fluids	
Pump types, S1F, S15, S20, and S30 provided with the pulse output option	II 2 G Ex ia c IIC T5 II 3/2 G Ex ia c IIC T5 II 2 D Ex c iaD 20 IP67 T100°C	KEMA 09ATEX0071 X CE 0344	KEMA 09ATEX0071 X KEMA 09ATEX0071 X KEMA 09ATEX0071 X	No Yes Yes
Pump types, S1F, S15, S20, and S30 provided with the integral solenoid option	II 2 G EEx m c II T5 II 3/2 G EEx m c II T5 II 2 D c IP65 T100°C	KEMA 09ATEX0071 X CE 0344	KEMA 09ATEX0071 X KEMA 09ATEX0071 X KEMA 09ATEX0071 X	No Yes Yes
Pump types, HDB1½, HDB40, HDB2, HDB50, HDB3, HDF1, HDF25, HDF2, HDF3M, PB¼, S05, S1F, S15, S20, S30, SB1, SB25, ST1½, ST40, G15, G20, and G30, without the above listed options, no aluminum parts	II 1 G c T5 II 3/1 G c T5 II 1 D c T100°C I M1 c I M2 c	KEMA 09ATEX0071 X KEMA 09ATEX0072 X CE 0344	KEMA 09ATEX0071 X KEMA 09ATEX0071 X KEMA 09ATEX0071 X KEMA 09ATEX0071 X KEMA 09ATEX0072 X	No Yes Yes No Yes
Pump types, DMF2, DMF3, HDB1½, HDB40, HDB2, HDB50, HDB3, HDF1, HDF25, HDF2, HDF3M, PB¼, S05, S1F, S15, S20, S30, SB1, SB25, SE½, ST1, ST25, ST1½, ST40, U1F, G05, G1F, G15, G20, and G30	II 2 G c T5 II 3/2 G c T5 II 2 D c T100°C	KEMA 09ATEX0072 X CE	KEMA 09ATEX0072 X KEMA 09ATEX0072 X KEMA 09ATEX0072 X	No Yes Yes
Surge Suppressors all types	II 2 G T5 II 3/2 G T5 II 2 D T100°C	KEMA 09ATEX0073 CE	KEMA 09ATEX0073 KEMA 09ATEX0073 KEMA 09ATEX0073	No Yes Yes

EC Type Certificate No. Pumps: KEMA 09ATEX0071 X
Type Certificate No. Pumps: KEMA 09ATEX0072 X
Type Certificate No. Suppressors: KEMA 09ATEX0073