



BLAGDON PUMP[®]

**PROVEN
PERFORMANCE
RELIABLE** PUMPING
SOLUTIONS





ABOUT BLAGDON

Our Background

Blagdon Pump was founded in the early 1950's in the North East of England as a specialist pump manufacturer. In 1979 production of **Air Operated Double Diaphragm (AODD)** Pumps commenced and Blagdon soon became a local market leader. In 1997 the U.S. based international company, IDEX Corporation, acquired Blagdon Pump to strengthen their global position in the AODD market. Blagdon Pump transferred operations to Ireland in 2009 and currently manufactures AODD pumps in both Ireland and Mansfield, Ohio, USA. Blagdon Pump is dynamic and evolving with the goal of making every customer experience satisfactory. Blagdon Pump can be relied on for your AODD pump requirements.

Our Mission

Blagdon AODD pumps provide high performance, reliable solutions for your pumping needs. We specialise in extreme condition environments and applications, keeping your process moving both above and below ground.

Our Website

We are committed to offering you a dedicated sales and after sales service which is second to none. Now you can keep up to date with developments as they happen with our website, www.blagdonpump.com. We look forward to working with you.

Blagdon Certifications



ATEX



EAC



CE



FDA

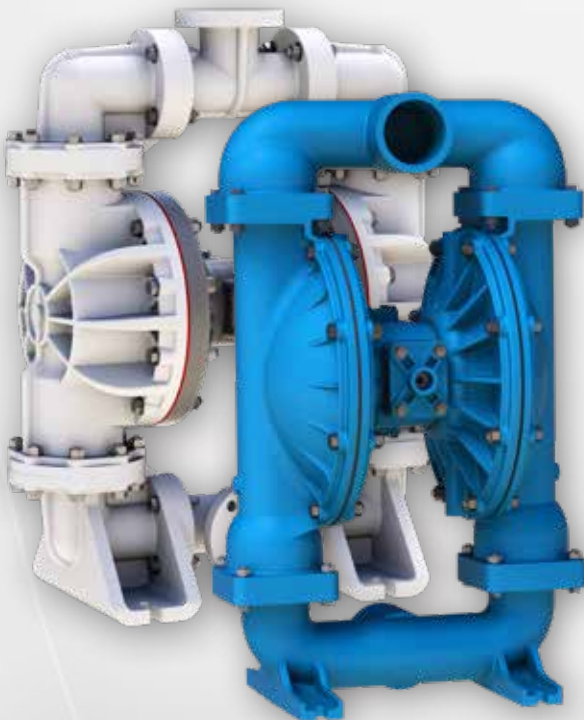

B75 NON-METALLIC PUMP

- The best choice for bulk chemical transfer applications.
- Available in corrosion resistant Polypropylene or PVDF.
- Class leading maximum flow rate and efficiency.
- Stainless steel bolted construction.

X75 METALLIC PUMP

- Unique combination of best in class max flow rates and lowest air consumption makes them the most efficient and economical pumps available.
- Requires up to 56% less air to operate, reducing the load on your compressed air system and lowering operating costs.



Air operated double diaphragm pumps have long been recognised as the “work horse” of the industry for handling difficult liquids at relatively low pressures and flows. The range of applications is virtually limitless. Blagdon AODD pumps come in many sizes and choices of materials of construction. Almost every type of liquid from highly corrosive acids through high viscosity paints and adhesives, to food and drink products can be pumped.

Blagdon 1/2", 1" and 2" hygienic pumps in polished 316L stainless steel



Blagdon 1/2", 1", 1 1/2" and 2" FDA compliant pumps in polished steel plus assorted standard fluid fittings



Blagdon 1" and 2" high pressure 2:1 pumps available in aluminum, stainless steel



Blagdon metallic pumps available in aluminum, cast iron, stainless steel from 1/4" to 3"



Blagdon non-metallic pumps available in conductive polypropylene, and kynar (PVDF) from 1/4" to 3"



100 PSI (7 Bar)

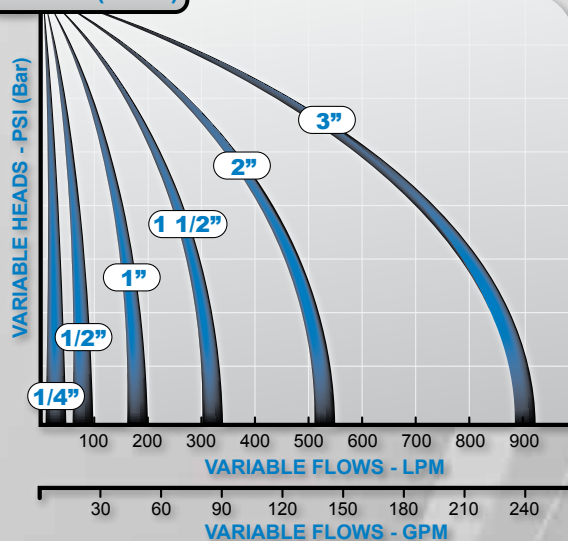

Individual specification sheets available for download at www.blagdonpump.com



BLAGDON BENEFITS

Blagdon offers an extensive pump range for handling fluid media safely and cost effectively. We offer low cost ownership, by combining high quality wear parts with low price spares and a vast array of accessories. A flexible modular design of pumps means we can offer short lead times and high degree of customising opportunities. Our experienced staff can provide instant support for installation, servicing, maintenance or a technical enquiry. We offer a fast spares delivery service, with many items in stock for immediate delivery.

Key Features and Benefits of a Blagdon Pump

- Can run dry without damage or heat build up
- Fully submersible
- Designed to operate at low noise levels
- Leak-free air valves, easily removed for servicing
- Easily maintained – Stripped down quickly without any specialist tools
- Self priming to over 6 metres (19.7 Feet)
- Can safely “dead head” against closed discharge
- Low degradation and minimum product agitation
- Low start up pressures
- Portable and compact – can be remotely controlled
- Safe in hazardous areas – No sparking – Air-driven



How Air-Operated Double Diaphragm Pumps Operate

The Pump Chambers are alternatively filled and emptied by drawing fluid in through a common (suction) inlet (C), and out through a common (discharge) outlet (D). The diaphragms in each chamber are linked by a common shaft, so that they move backwards and forwards in unison. Compressed air is directed by the air valve alternatively, behind each diaphragm, to power discharge strokes. Pump speed, fluid output and pressure (or head) is controlled by increasing or decreasing the flow of compressed air to the pump.

Operation Sequence

Suction Cycle:

Fluid is drawn into the suction manifold at (C), by the suction stroke of the diaphragm and into chamber (B).

This ‘opens’ the ball valve (2) to allow liquid to enter the chamber. Ball valve (4) is drawn into the valve seat and ‘closed’ by the diaphragm suction stroke.

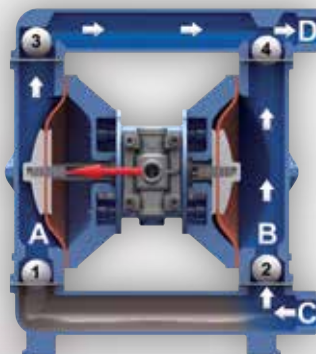

Discharge Cycle:

In chamber (A), air has been applied to the rear of the diaphragm to force out the fluid in the chamber through the ball valve (3) to the discharge manifold (D).

The discharge stroke ‘closes’ the ball valve (1) to prevent further liquid entering the chamber.

This cycle is repeated to provide a continuous flow to the discharge manifold at outlet (D).

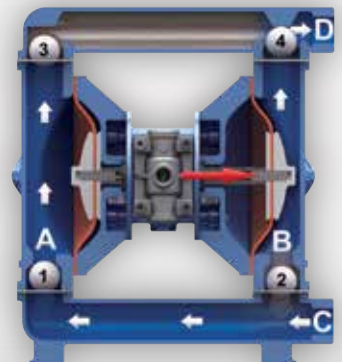



A full list of chemicals and recommended elastomers is available on request, or our sales office can advise on the best pumps and materials for specific media.

Typical range of products you can pump.

- **ABRASIVES:** Clay slip, titanium dioxide, mill scale
- **ACIDS:** All mineral and organic acids
- **ADHESIVE:** Solvent and water based
- **ALCOHOLS:** Chemicals
- **CAUSTICS:** Acids
- **CEMENT:** Slip, glazes, clay
- **COSMETICS:** Creams, emulsions, detergents
- **DRILLING:** Mud, grout, lubricants
- **DRINKS:** Soft drinks, spirits, beer, wine, milk
- **EXPLOSIVES:** Suspensions of gun powder, explosives, etc.
- **FOODS:** Liquid and semi-solid foods, flavourings
- **INKS & DYES:** Printing inks, dyes, sizes and solvents
- **OILS:** Petrol, diesel, hydraulic, and cutting oils, lube oils, animal and vegetable oils and greases
- **PAINT:** Emulsions, latexes, pigments, solvents, resins, thinners
- **PHARMACEUTICALS:** Liquids, creams, and compounds
- **PLATING:** Aggressive acids, salts, sludge and effluents
- **PULPS:** paper, wood, sizes, bleaches
- **RESINS:** Natural and synthetics, water and solvent based, monomeric and polymeric plastics
- **RUBBER:** Gum, latex
- **SLUDGE & WASTE:** Sewage, effluents, coal and lime slurry
- **SOLVENTS:** Aromatic and aliphatics, ketones, aldehydes, esters and chlorinated hydrocarbons, de-icing fluids
- **TIMBER PRESERVATIVES:** Creosote, turpentine, copper naphthenate
- **WATER:** All types

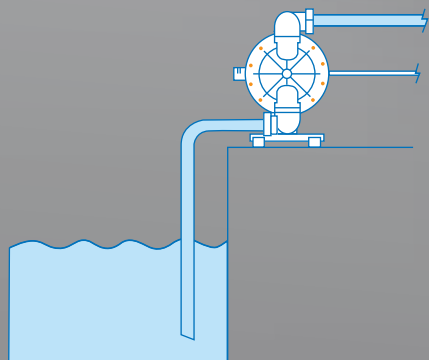
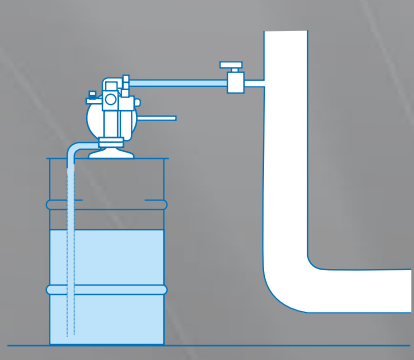
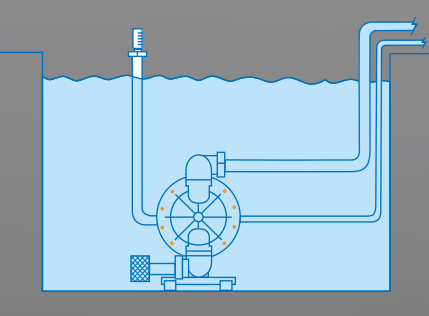
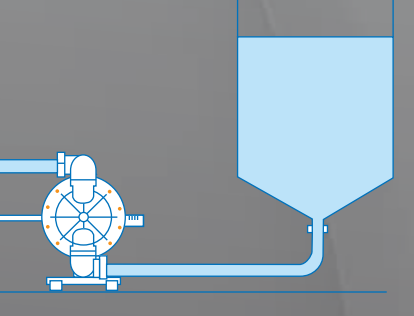
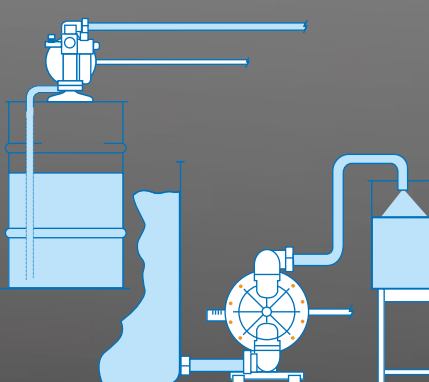
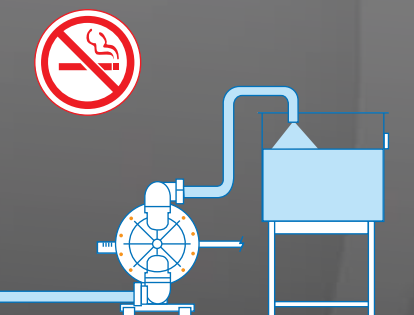
<p style="text-align: center;">Self Priming</p> 	<p style="text-align: center;">Filling / Injection / Dosing</p> 
<p style="text-align: center;">Submerged Operation</p> 	<p style="text-align: center;">Flooded Suction</p> 
<p style="text-align: center;">Permanent or Portable Options</p> 	<p style="text-align: center;">Safe for Hazardous Areas</p> <p>Only X-series (ATEX compliant) should be used in a hazardous area</p> 

Pump Duties

Blagdon pumps can be installed in any of the models illustrated to perform the following duties: Liquid Transfer, Slurry Handling, Filter Feeding, Circulation, De-watering, Low Pressure, Spray Supply, Tank/Sump/Barrel/Drum Filling and Emptying, Batching/Mixing/Metering/Dosing, and Chemical Injection, etc.



PORTFOLIO INFORMATION

Blagdon Portfolio Information	Pump Model/Size/Material	Fluid Contact Materials							Air Chamber Materials					Diaphragm											
		Conductive PTFE	Virgin PTFE	Aluminium	Cast Iron	PVDF	Polypropylene	Conductive Polypropylene	Stainless Steel	Polished Stainless	Aluminium	Cast Iron	Nickel Plated Aluminium	Polypropylene	Stainless Steel	Epoxy Coated Aluminium	Epoxy Coated Stainless Steel	Conductive PTFE	PTFE Coated Aluminium	Buna-N	EPDM (Inc. Food Grade)	Geolast	Polyester (Hytel)	Neoprene	
Metallic Pumps (Ball Valve)	B06 - 1/4" Stainless Steel																								
	B15 - 1/2" Aluminium			•						•											•	•		•	•
	B15 - 1/2" Stainless Steel									•					•						•	•		•	•
	B25 - 1" Aluminium			•						•											•	•		•	•
	B25 - 1" Cast Iron				•						•	•									•	•		•	•
	B25 - 1" Stainless Steel									•					•						•	•		•	•
	B40 - 1 1/2" Aluminium			•						•	•					•					•	•		•	•
	B40 - 1 1/2" Cast Iron				•						•	•									•	•		•	•
	B40 - 1 1/2" Stainless Steel									•		•				•					•	•		•	•
	B50 - 2" Aluminium			•						•	•										•	•		•	•
	B50 - 2" Cast Iron				•						•	•									•	•		•	•
	B50 - 2" Stainless Steel									•	•				•						•	•		•	•
	X75 - 3" Aluminium			•						•	•										•	•		•	•
	X75 - 3" Cast Iron				•						•	•									•	•		•	•
X75 - 3" Stainless Steel									•	•										•	•		•	•	
Non-Metallic Pumps (Ball Valve)	B06 - 1/4" Polypropylene												•											•	
	B06 - 1/4" PVDF					•							•											•	
	B10 - 3/8" Polypropylene					•							•										•	•	
	B15 - 1/2" Polypropylene						•	•							•	•					•	•		•	
	B15 - 1/2" PVDF					•									•	•					•	•		•	
	B25 - 1" Polypropylene						•	•							•	•					•	•		•	
	B25 - 1" PVDF					•									•	•					•	•		•	
	B50 - 2" Polypropylene						•	•							•	•					•	•		•	
	B50 - 2" PVDF					•									•	•					•	•		•	
	B75 - 3" Polypropylene						•								•	•					•	•		•	
B75 - 3" PVDF					•									•	•					•	•		•		
Metallic Pumps (Flap Valve)	X25 - 1" Aluminium			•						•										•	•		•	•	
	X25 - 1" Cast Iron				•						•										•	•		•	
	X25 - 1" Stainless Steel									•											•	•		•	
	X50 - 2" Aluminium			•						•	•										•	•		•	
	X50 - 2" Cast Iron				•						•	•									•	•		•	
	X50 - 2" Stainless Steel									•	•										•	•		•	
	X75 - 3" Aluminium			•						•	•										•	•		•	
X75 - 3" Cast Iron				•						•	•									•	•		•		
X75 - 3" Stainless Steel									•	•										•	•		•		
Hygienic Pumps	B15 - 1/2" Hygienic									•				•							•				
	B25 - 1" Hygienic									•				•							•				
	B50 - 2" Hygienic									•				•							•				
High Pressure Pumps	B25 - 1" Standard 2:1			•	•					•	•				•					•	•		•	•	
	B25 - 1" Full Flow 2:1			•						•					•						•	•		•	
	B50 - 2" Full Flow 2:1			•						•					•						•	•		•	
FDA Pumps	B15 - 1/2" Stainless Steel									•				•							•				
	B25 - 1" Stainless Steel									•				•							•				
	B40 - 1 1/2" Stainless Steel									•				•							•				
	B50 - 2" Stainless Steel									•				•							•				
PTFE Pumps	B15 - 1/2" Conductive PTFE	•												•											
	B15 - 1/2" Virgin PTFE		•												•										
	B25 - 1" Conductive PTFE	•															•								
	B25 - 1" Virgin PTFE		•																						



Materials					Check Valve Materials					Max. Flow		Fluid Connections			Air Inlet	Max. Op Pressure		Max. Solid Size (mm)		
PTFE (One Piece)	Polyurethane	Santoprene	PTFE	Viton	Buna-N	EPDM (Inc. Food Grade)	Neoprene	Santoprene	Stainless Steel	PTFE	Viton	UKGPM	L/Min	BSP(F)	ANSI Flange	RJT(M)	BSP (NPT)F	Bar	PSI	
•	•	•	•	•	•	•	•	•	•	•	•	4	18	1/4"			1/4"	8.6	125	1
•	•	•	•	•	•	•	•	•	•	•	•	14	60	1/2"			1/4"	8.6	125	2
•	•	•	•	•	•	•	•	•	•	•	•	14	60	1/2"			1/4"	8.6	125	2
•	•	•	•	•	•	•	•	•	•	•	•	40	180	1"			3/8"	8.6	125	3
•	•	•	•	•	•	•	•	•	•	•	•	40	180	1"			3/8"	8.6	125	3
•	•	•	•	•	•	•	•	•	•	•	•	40	180	1"			3/8"	8.6	125	3
•	•	•	•	•	•	•	•	•	•	•	•	76	320	1 1/2"			3/8"	8.6	125	6
•	•	•	•	•	•	•	•	•	•	•	•	76	320	1 1/2"			3/8"	8.6	125	6
•	•	•	•	•	•	•	•	•	•	•	•	76	320	1 1/2"			3/8"	8.6	125	6
•	•	•	•	•	•	•	•	•	•	•	•	120	530	2"			3/4"	8.6	125	6
•	•	•	•	•	•	•	•	•	•	•	•	120	530	2"			3/4"	8.6	125	6
•	•	•	•	•	•	•	•	•	•	•	•	120	530	2"			3/4"	8.6	125	6
•	•	•	•	•	•	•	•	•	•	•	•	202	889	3"			3/4"	8.6	125	10
•	•	•	•	•	•	•	•	•	•	•	•	202	889		3" 150 RF		3/4"	8.6	125	10
•	•	•	•	•	•	•	•	•	•	•	•	202	889		3" 150 RF		3/4"	8.6	125	10
•	•	•	•	•	•	•	•	•	•	•	•	4	16	1/4"			1/4"	5	72	1
•	•	•	•	•	•	•	•	•	•	•	•	4	16	1/4"			1/4"	5	72	1
•	•	•	•	•	•	•	•	•	•	•	•	6	26	3/8"			1/4"	7	100	2
•	•	•	•	•	•	•	•	•	•	•	•	1	48		1/2" 150 RF		1/4"	8	116	2
•	•	•	•	•	•	•	•	•	•	•	•	1	48		1/2" 150 RF		1/4"	8	116	2
•	•	•	•	•	•	•	•	•	•	•	•	34	152		1" 150 RF		3/8"	8	116	3
•	•	•	•	•	•	•	•	•	•	•	•	34	152		1" 150 RF		3/8"	8	116	3
•	•	•	•	•	•	•	•	•	•	•	•	120	530		2" 150 RF		3/4"	8.6	125	6
•	•	•	•	•	•	•	•	•	•	•	•	120	530		2" 150 RF		3/4"	8.6	125	6
•	•	•	•	•	•	•	•	•	•	•	•	238	901		3" 150 RF		3/4"	6.9	100	18
•	•	•	•	•	•	•	•	•	•	•	•	238	901		3" 150 RF		3/4"	6.9	100	18
•	•	•	•	•	•	•	•	•	•	•	•	70	265	1"			1/2"	8.6	125	25
•	•	•	•	•	•	•	•	•	•	•	•	70	265	1"			1/2"	8.6	125	25
•	•	•	•	•	•	•	•	•	•	•	•	70	265	1"			1/2"	8.6	125	25
•	•	•	•	•	•	•	•	•	•	•	•	140	530	2"			3/4"	8.6	125	50
•	•	•	•	•	•	•	•	•	•	•	•	140	530	2"			3/4"	8.6	125	50
•	•	•	•	•	•	•	•	•	•	•	•	140	530	2"			3/4"	8.6	125	50
•	•	•	•	•	•	•	•	•	•	•	•	260	988		3" 150 RF		3/4"	8.6	125	80
•	•	•	•	•	•	•	•	•	•	•	•	260	988		3" 150 RF		3/4"	6.9	125	80
•	•	•	•	•	•	•	•	•	•	•	•	260	988		3" 150 RF		3/4"	6.9	125	80
•	•	•	•	•	•	•	•	•	•	•	•	17	75			1"	1/4"	8.6	125	2
•	•	•	•	•	•	•	•	•	•	•	•	31	136			1"	3/8"	8.6	125	3
•	•	•	•	•	•	•	•	•	•	•	•	114	500			2"	3/4"	8.6	125	10
•	•	•	•	•	•	•	•	•	•	•	•	20	86	1"			1/4"	16	232	3
•	•	•	•	•	•	•	•	•	•	•	•	28	125	1"			3/8"	16	232	3
•	•	•	•	•	•	•	•	•	•	•	•	80	350	2"			3/4"	16	232	6
•	•	•	•	•	•	•	•	•	•	•	•	14	60	1/2"			1/4"	8.6	125	2
•	•	•	•	•	•	•	•	•	•	•	•	40	180	1"			3/8"	8.6	125	3
•	•	•	•	•	•	•	•	•	•	•	•	76	320	1 1/2"			3/8"	8.6	125	6
•	•	•	•	•	•	•	•	•	•	•	•	120	530	2"			3/4"	8.6	125	6
•	•	•	•	•	•	•	•	•	•	•	•	1	48		1/2" 150 RF		1/4"	7	100	2
•	•	•	•	•	•	•	•	•	•	•	•	1	48		1/2" 150 RF		1/4"	7	100	2
•	•	•	•	•	•	•	•	•	•	•	•	34	136		1" 150 RF		3/8"	7	100	3
•	•	•	•	•	•	•	•	•	•	•	•	34	136		1" 150 RF		3/8"	7	100	3



Diaphragm & Ball Valve Options

- Uses, Temperature Limits & Specific Gravity

Elastomer	Main Properties and Uses	Operating Temperatures			Ball Valve S.G.	
		Min	Optimum	Max	Standard	Weighted
Buna-N	General purpose for use on water, most hydrocarbons and mild chemicals	-18F -28C	50 to 140F 10 to 60C	176F 80C	1.23	2.64
EPDM	Caustic solutions and dilute acids. Poor on oils and solvents	-11F -24C	50 to 140F 10 to 60C	212F 100C	1.23	2.64
Geolast	General purpose for use on water, most hydrocarbons and mild chemicals	-10F -23C	50 to 140F 10 to 60C	212F 100C	1.0	N/A
Neoprene	Excellent abrasion resistance. Widely used in the ceramics industry on dirty wate, clays, grout etc.	-4F -20C	50 to 130F 10 to 54C	212F 100C	1.23	2.64
Polyester	High mechanical strength. Suitable with most oils, solvents and hydrocarbons	-40F -40C	50 to 130F 10 to 54C	158F 70C	N/A	N/A
Polyurethane	Excellent abrasion resistance, dirty water, oils and hydrocarbons	-40F -40C	50 to 130F 10 to 54C	158F 70C	N/A	N/A
PTFE	Aggressive chemicals and solvents but with low abrasion resistance	32F 0C	50 to 212F 10 to 100C	356F 180C	N/A	N/A
Santoprene	Caustic solutions and dilute acids. Excellent abrasion resistance	-10F -23C	50 to 140F 10 to 60C	212F 100C	0.98	N/A
Stainless Steel	N/A	N/A	N/A	N/A	7.80	N/A
Viton	Aggressive chemicals and most solvents. High temperature uses	0F -18C	75 to 212F 24 to 100C	356F 180C	1.80	3.2

Pump Identification

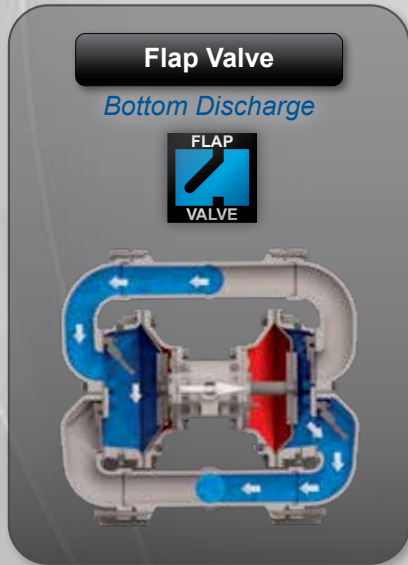
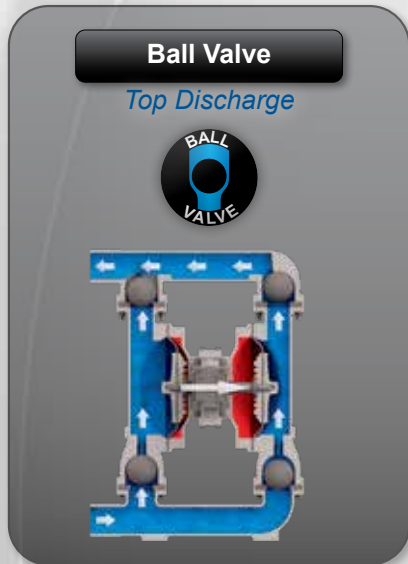

Viscosity Guide

This table is a guide only – cps = centipoise

X75 - 3" Pumps		Maximum 25000							
B50 - 2" Pumps		Maximum 12000							
B40 - 1 1/2" Pumps		Maximum 12000							
B25 - 1" Pumps		Maximum 5000							
B15 - 1/2" Pumps		Maximum 5000							
B10 - 3/8" Pumps		Maximum 2000							
B06 - 1/4" Pumps		Maximum 2000							
1	200	500	1000	2000	4000	10000	15000		
Water 1 cps	Tomato Juice 176 cps	SAE 30 Oil 352 cps	Glycerine 880 cps	SAE 50 Oil 1561 cps	Glue 3000 cps	Mayonnaise 5000 cps	Molasses B 8640 cps	Scour Cream 15200 cps	SAE 70 Oil 17640 cps

Recommended Installation Guidelines

For best results, the factory recommends installing the surge suppressor on the discharge side of the pump. Though the more common top-ported pump is shown here, this recommendation also applies to bottom, side and dual-ported diaphragm pumps.

The compressed air supply line to the surge suppressor should connect before a filter/regulator unit limited to inlet air of 125 PSI. To reduce piping and pump connection stresses, we recommend flexible connections on both inlet and outlet piping and air inlet connections.

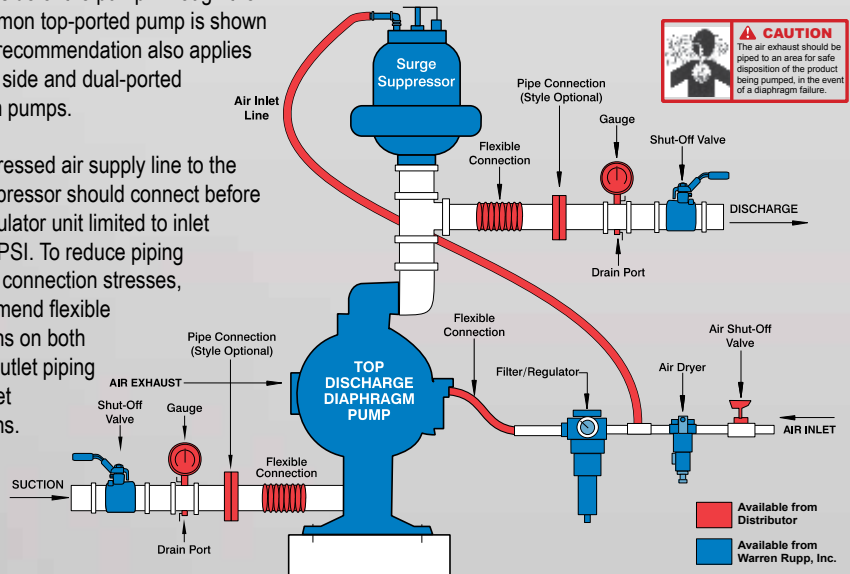

- Simple construction, easy to maintain
- Self priming, ideal for emptying containers
- Pressures to 5 bar (73 PSI)
- Flow rates up to 16 litres/minute (4.3 gal/min)
- Bolted construction for safety
- Low break out pressure requirement
- Reliable pneumatic air valve system



Typical Code = B06. 04. PP. BB. TTP

MODEL - B06

DESIGN LEVEL

WETTED COMPONENTS

P: POLYPROPYLENE
K: KYNAR (PVDF)

NON-WETTED COMPONENTS

P: POLYPROPYLENE (Glass Filled)

VALVE TYPE

B: BALL

SUCTION ORIENTATION

B: BOTTOM

VALVE SEATS

P: POLYPROPYLENE
K: KYNAR (PVDF)

VALVE BALLS

T: PTFE
V: VITON®
S: 316 STAINLESS STEEL

DIAPHRAGMS

E: EPDM
H: POLYESTER
R: SANTOPRENE®
T: PTFE
V: VITON®
O: ONE PIECE PTFE

Example above: B06.04.PP.BB.TTP refers to B06 model, Design Level 4 with Polypropylene wetted components, Glass filled Polypropylene non-wetted components, with PTFE Diaphragms and Valve Balls and Polypropylene Seats.

Technical Data

NON-METALLIC SERIES B06 POLYPROPYLENE & PVDF

Maximum Delivery:	16 ltrs/min (4.3 gal/min)
Max. Working Pressure:	5 bar (73 PSI)
Max. Solid Particle Size:	1 mm. (0.04")
Air Inlet:	1/4" BSP(F) / NPT
Temperature Limits:	Determined by Elastomers
Suction Lift (Dry):	1.5 m. (4.9')
Suction Lift (Wet):	4.1 m. (13.5')
Fluid Inlet/Outlet:	1/4" BSP / NPT
Installation:	Wall or surface mounted
Accessories Included:	Exhaust air Silencer

Shipping Weights:

Polypropylene	1.7 kg. (3.8 lbs.)
PVDF	1.9 kg. (4.2 lbs.)

Shipping Dimensions: 240 x 180 x 200 mm.
(9.5" x 7.1" x 7.9")

Performance Curve

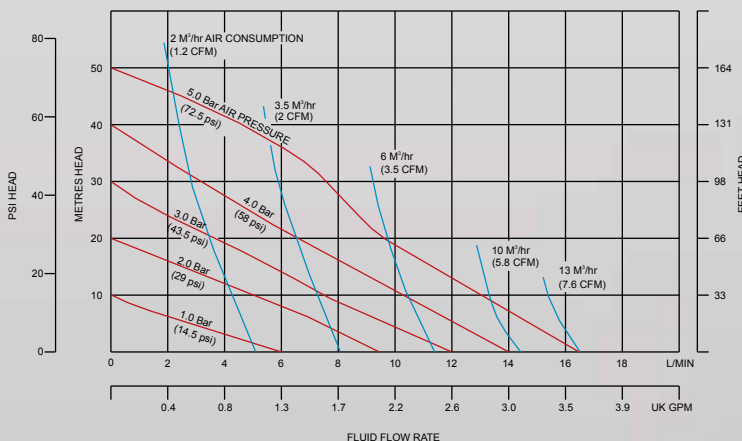

Note: The above Performance Curve has been determined under the following conditions: flooded suction, pumping clean water through a calibrated electronic flow meter with pulsation dampener and silencer fitted.

Dimensions

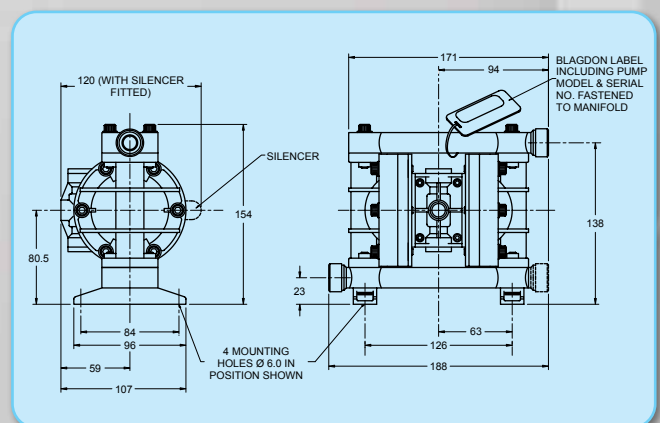

- Simple construction, easy to maintain
- Self priming, ideal for emptying containers
- High quality investment cast design
- Pressures to 8.6 bar (125 PSI)
- Flow rates up to 18 litres/minute (4.8 gal/min)
- Bolted construction for safety
- Reliable pneumatic air valve system
- Constructed from 316L Stainless Steel



Typical Code = B06. 04. SS. BB. TTS

MODEL - B06: Standard
X06: ATEX Compliant

DESIGN LEVEL

WETTED COMPONENTS
S: 316L STAINLESS STEEL

NON-WETTED COMPONENTS
S: 316L STAINLESS STEEL

VALVE TYPE
B: BALL

SUCTION ORIENTATION
B: BOTTOM

VALVE SEATS
S: 316L STAINLESS STEEL

VALVE BALLS
T: PTFE
V: VITON®
S: 316 STAINLESS STEEL

DIAPHRAGMS
E: EPDM
H: POLYESTER
R: SANTOPRENE®
T: PTFE
V: VITON®
O: ONE PIECE PTFE

Technical Data

METALLIC SERIES B06 STAINLESS STEEL

Maximum Delivery:	18 ltrs/min (4.8 gal/min)
Max. Working Pressure:	8.6 bar (125 PSI)
Max. Solid Particle Size:	1 mm. (0.04")
Air Inlet:	1/4" BSP(F) / NPT
Temperature Limits:	Determined by Elastomers
Suction Lift (Dry):	1.5 m. (4.9')
Suction Lift (Wet):	4.1 m. (13.5')
Fluid Inlet/Outlet:	1/4" BSP / NPT
Installation:	Wall or surface mounted
Accessories Included:	Exhaust air Silencer

Shipping Weight:

Stainless Steel 3.7 kg. (8.2 lbs.)

Shipping Dimensions: 240 x 180 x 200 mm.
(9.5" x 7.1" x 7.9")

Performance Curve

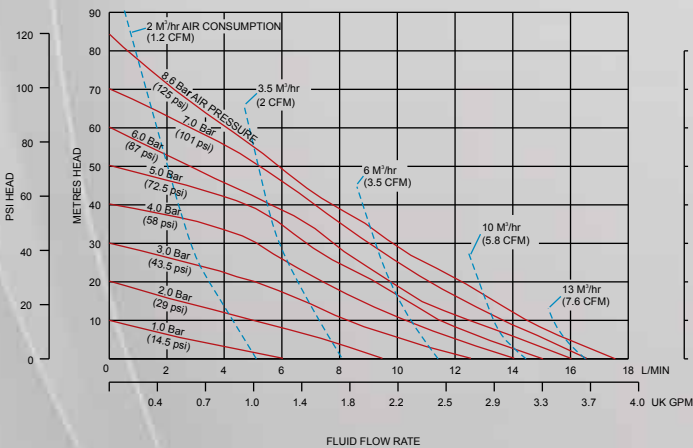

Dimensions

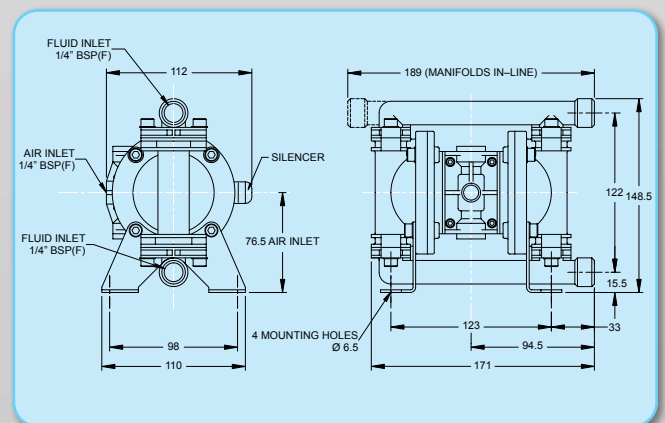

Note: The above Performance Curve has been determined under the following conditions: flooded suction, pumping clean water through a calibrated electronic flow meter with pulsation dampener and silencer fitted.

- Simple construction, easy to maintain
- Self priming, ideal for emptying containers
- Strong, robust design
- Pressures to 8 bar (116 PSI)
- Flow rates up to 48 litres/minute (13 gal/min)
- Flanged or screwed end connections
- Pneumatic air valve, reliable and easy

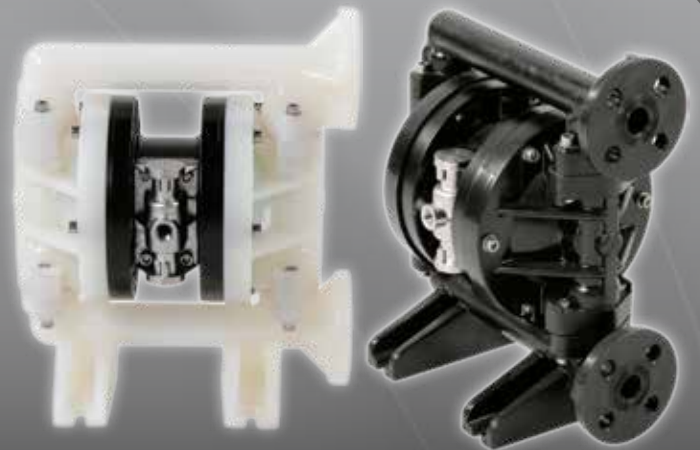

Typical Code = B15. 01. PT. BB. TTP -LF

MODEL - B15: Standard
X15: ATEX Compliant

DESIGN LEVEL

WETTED COMPONENTS
P: POLYPROPYLENE
K: KYNAR (PVDF)
G: CONDUCTIVE POLYPROPYLENE

NON-WETTED COMPONENTS
T: EPOXY COATED ALUMINUM
W: EPOXY COATED STAINLESS STEEL

VALVE TYPE
B: BALL

SUCTION ORIENTATION
B: BOTTOM

LUBE FREE

VALVE SEATS
B: BUNA-N T: PTFE
E: EPDM V: VITON
N: NEOPRENE
P: POLYPROPYLENE

VALVE BALLS
B: BUNA-N K: KYNAR (PVDF)
E: EPDM V: VITON
N: NEOPRENE
S: 316 STAINLESS STEEL

DIAPHRAGMS
B: BUNA-N
P: POLYPROPYLENE
E: EPDM R: SANTROPENE
T: PTFE V: VITON
N: NEOPRENE
O: ONE PIECE PTFE

*X Series ATEX pumps are ONLY applicable to Conductive Polypropylene pumps.

Technical Data

MOULDED NON-METALLIC SERIES B15 POLYPROPYLENE & PVDF

Maximum Delivery:	48 ltrs/min (13 gal/min)
Max. Working Pressure:	8 bar (116 PSI)
Max. Solid Particle Size:	2 mm. (0.08")
Air Inlet:	1/4" BSP(F) / NPT
Temperature Limits:	Determined by Elastomers
Suction Lift (Dry):	4.6 m. (15.1')
Suction Lift (Wet):	6.1 m. (20')
Fluid Inlet/Outlet:	1/2 ANSI #150 RF Flanged
Installation:	Wall or surface mounted
Accessories Included:	Exhaust air Silencer

Shipping Weights:

Polypropylene/Aluminum	5.3 kg. (11.7 lbs.)
PVDF/Aluminum	7 kg. (15.4 lbs.)
Polypropylene/Stainless Steel	12 kg. (26.5 lbs.)
PVDF/Stainless Steel	13.5 kg. (29.8 lbs.)

Shipping Dimensions: 320 x 200 x 340 mm.
(12.6" x 7.9" x 13.4")

Performance Curve

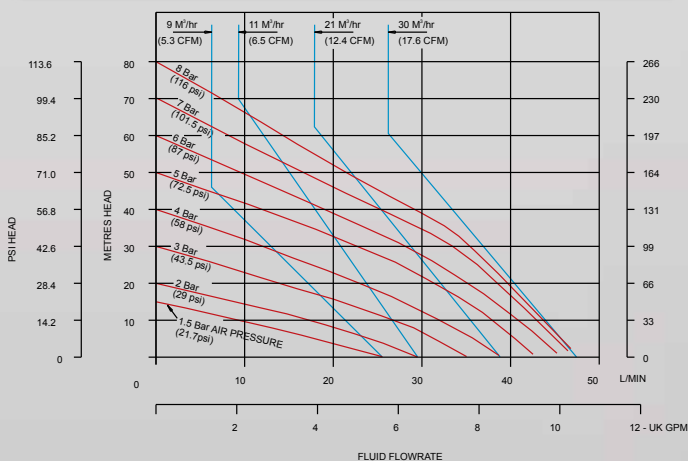

Note: The above Performance Curve has been determined under the following conditions: flooded suction, pumping clean water through a calibrated electronic flow meter with pulsation dampener and silencer fitted.

Dimensions

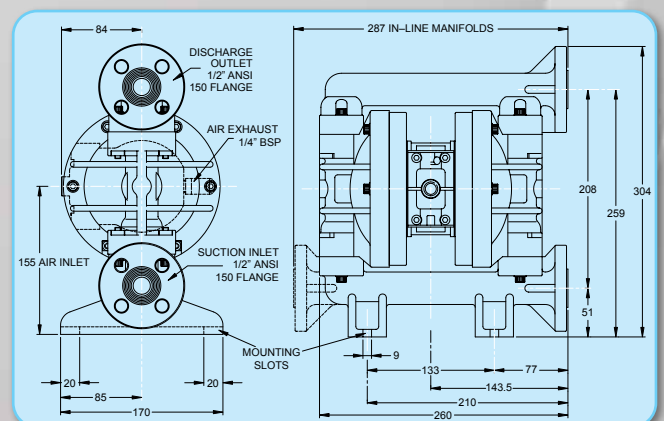

- Simple construction, easy to maintain
- Self priming, ideal for emptying containers
- Pressures to 8.6 bar (125 PSI)
- Flow rates up to 60 litres/minute (16 gal/min)
- Bolted construction for greater integrity
- Reliable pneumatic air valve design
- Portable



Typical CODE = B15. 01. AA. BB. TTS -LF

MODEL - B15: Standard
X15: ATEX Compliant

DESIGN LEVEL

WETTED COMPONENTS
A: ALUMINUM

NON-WETTED COMPONENTS
A: ALUMINUM

VALVE TYPE
B: BALL

SUCTION ORIENTATION
B: BOTTOM

LUBE FREE

VALVE SEATS

A: ALUMINUM
B: BUNA-N
E: EPDM
N: NEOPRENE
V: VITON
S: 316 STAINLESS STEEL

VALVE BALLS

B: BUNA-N V: VITON
E: EPDM T: PTFE
N: NEOPRENE
S: 316 STAINLESS STEEL

DIAPHRAGMS

B: BUNA-N
E: EPDM
R: SANTROPENE
T: PTFE V: VITON
N: NEOPRENE
O: ONE PIECE PTFE

Technical Data

METALLIC SERIES B15 ALUMINUM

Maximum Delivery: 60 ltrs/min (16 gal/min)
Max. Working Pressure: 8.6 bar (125 PSI)
Max. Solid Particle Size: 2 mm. (0.08")
Air Inlet: 1/4" BSP(F) / NPT
Temperature Limits: Determined by Elastomers
Suction Lift (Dry): 4.6 m. (15.1')
Suction Lift (Wet): 6.1 m. (20')
Fluid Inlet/Outlet: 1/2 BSP / NPT
Installation: Wall or surface mounted
Accessories Included: Exhaust air Silencer

Shipping Weight:

Aluminum 5.9 kg. (13 lbs.)

Shipping Dimensions: 320 x 200 x 340 mm.
(12.6" x 7.9" x 13.4")

Performance Curve

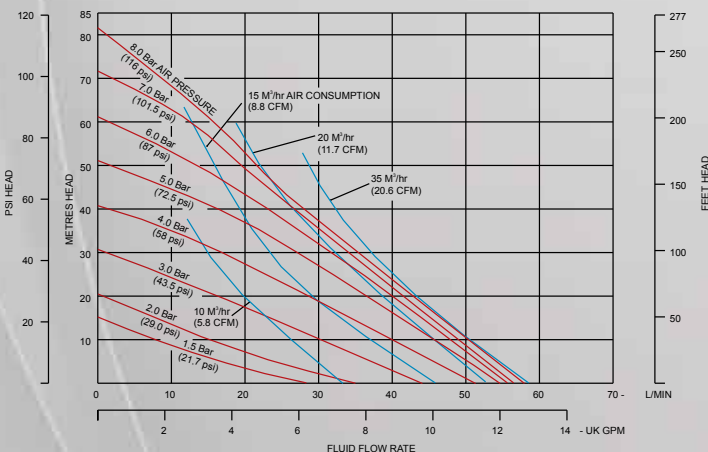

Dimensions

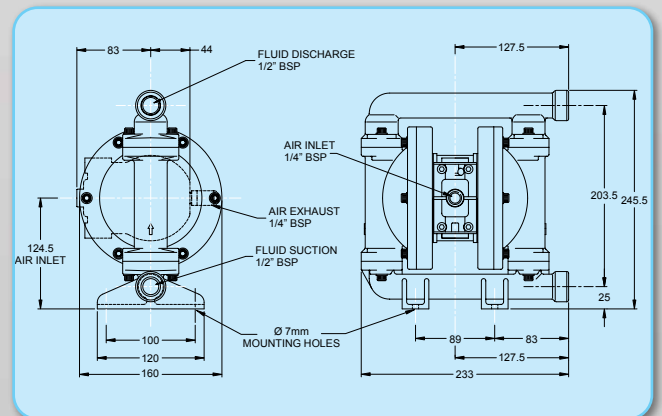

Note: The above Performance Curve has been determined under the following conditions: flooded suction, pumping clean water through a calibrated electronic flow meter with pulsation dampener and silencer fitted.

- Simple construction, easy to maintain
- Self priming, ideal for emptying containers
- Pressures to 8.6 bar (125 PSI)
- Flow rates up to 60 litres/minute (16 gal/min)
- Bolted construction for greater integrity
- 316L Stainless Steel



Typical CODE = B15. 01. SA. BB. TTS -LF

MODEL - B15: Standard
X15: ATEX Compliant

DESIGN LEVEL

WETTED COMPONENTS
S: 316 STAINLESS STEEL

NON-WETTED COMPONENTS
A: ALUMINUM
S: 316 STAINLESS STEEL

VALVE TYPE
B: BALL

SUCTION ORIENTATION
B: BOTTOM

LUBE FREE

VALVE SEATS
S: 316 STAINLESS STEEL

VALVE BALLS
B: BUNA-N T: PTFE
E: EPDM V: VITON
N: NEOPRENE
S: 316 STAINLESS STEEL

DIAPHRAGMS
B: BUNA-N
E: EPDM
R: SANTROPENE
T: PTF E V: VITON
N: NEOPRENE
O: ONE PIECE PTFE

Technical Data

METALLIC SERIES B15 STAINLESS STEEL

Maximum Delivery:	60 ltrs/min (16 gal/min)
Max. Working Pressure:	8.6 bar (125 PSI)
Max. Solid Particle Size:	2 mm. (0.08")
Air Inlet:	1/4" BSP(F) / NPT
Temperature Limits:	Determined by Elastomers
Suction Lift (Dry):	4.6 m. (15.1')
Suction Lift (Wet):	6.1 m. (20')
Fluid Inlet/Outlet:	1/2 BSP / NPT
Installation:	Wall or surface mounted
Accessories Included:	Exhaust air Silencer

Shipping Weights:

Stainless Steel/Aluminum	9.7 kg. (12.4 lbs.)
Stainless Steel	15 kg. (33.1 lbs.)

Shipping Dimensions: 320 x 200 x 340 mm.
(12.6" x 7.9" x 13.4")

Performance Curve

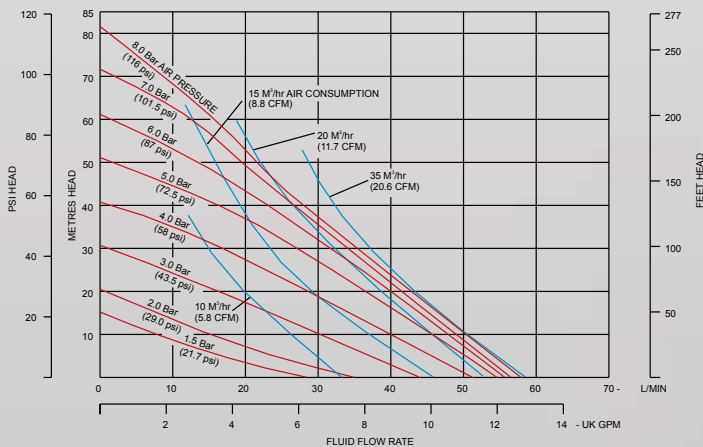

Note: The above Performance Curve has been determined under the following conditions: flooded suction, pumping clean water through a calibrated electronic flow meter with pulsation dampener and silencer fitted.

Dimensions

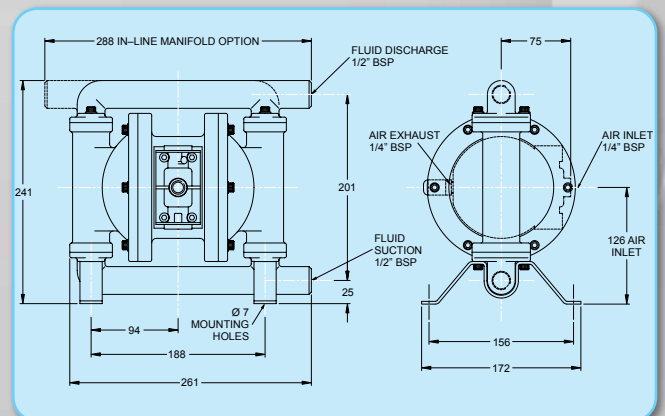

- Simple construction, easy to maintain
- Available in virgin and conductive PTFE
- Chemically inert
- Flanged end connections
- ATEX approved - intrinsically safe
- Reliable, proven pneumatic air valve
- Strong, robust design



Typical CODE = B15. 00. TS. BB. TTT -LF

MODEL - B15: Standard
X15: ATEX Compliant

DESIGN LEVEL

WETTED COMPONENTS
T: PTFE
4: CONDUCTIVE PTFE

NON-WETTED COMPONENTS
4: CONDUCTIVE PTFE
5: POLYETHYLENE (HDPE)
S: 316 STAINLESS STEEL

VALVE TYPE
B: BALL

SUCTION ORIENTATION
B: BOTTOM

LUBE FREE

VALVE SEATS
T: PTFE

VALVE BALLS
T: PTFE

DIAPHRAGMS
T: PTFE
X: PTFE/WITON (HIGH TEMP.)

Technical Data

NON-METALLIC SERIES B15 CONDUCTIVE / VIRGIN PTFE

Maximum Delivery:	48 ltrs/min (13 gal/min)
Max. Working Pressure:	7 bar (102 PSI)
Max. Solid Particle Size:	2 mm. (0.08")
Air Inlet:	1/4" BSP(F) / NPT
Temperature Limits:	Determined by Elastomers
Suction Lift (Dry):	4.6 m. (15.1')
Suction Lift (Wet):	6.1 m. (20')
Fluid Inlet/Outlet:	1/2 BSP / NPT
Installation:	Wall or surface mounted
Accessories Included:	Exhaust air Silencer

Shipping Weights:

Conductive PTFE	16 kg. (35.3 lbs.)
Virgin PTFE	16 kg. (35.3 lbs.)

Shipping Dimensions: 320 x 200 x 340 mm.
(12.6" x 7.9" x 13.4")

*X Series ATEX pumps are ONLY applicable to Conductive PTFE pumps.

Performance Curve

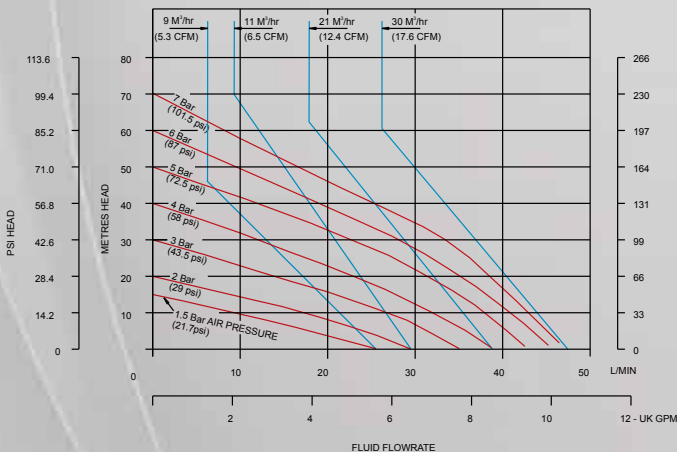

Note: The above Performance Curve has been determined under the following conditions: flooded suction, pumping clean water through a calibrated electronic flow meter with pulsation dampener and silencer fitted.

Dimensions

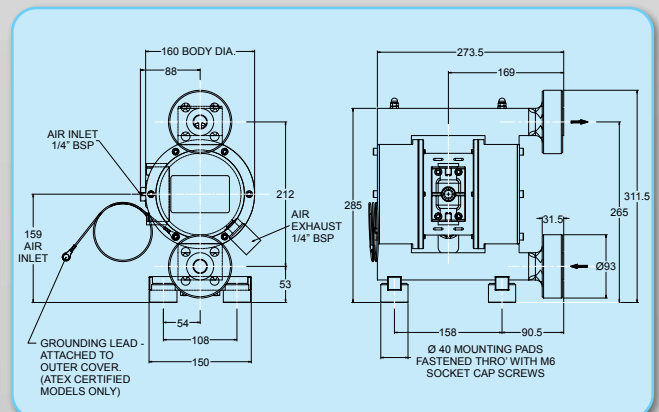

- Range of DIN/RJT and Ferrule connections
- Self priming, ideal for emptying containers
- Food grade elastomers-EPDM/PTFE
- Pressures to 8.6 bar (125 PSI)
- Capable of handling high viscosity & S.G.
- 316L stainless steel



Typical CODE = B15. 01. ZF. BB. TTS -LF

MODEL - B15: Standard
X15: ATEX Compliant

DESIGN LEVEL

WETTED COMPONENTS
Z: 316 STAINLESS STEEL
(POLISHED)

NON-WETTED COMPONENTS
S: 316 STAINLESS STEEL
F: NICKEL PLATED ALUMINUM

VALVE TYPE
B: BALL

SUCTION ORIENTATION
B: BOTTOM

LUBE FREE

VALVE SEATS
E: FOOD GRADE EPDM

VALVE BALLS
E: FOOD GRADE EPDM
T: PTFE
S: 316 STAINLESS STEEL

DIAPHRAGMS
E: FOOD GRADE EPDM
O: ONE PIECE PTFE

Technical Data

HYGIENIC SERIES B15 STAINLESS STEEL

Maximum Delivery:	75 ltrs/min (20 gal/min)
Max. Working Pressure:	8.6 bar (125 PSI)
Max. Solid Particle Size:	2 mm. (0.08")
Air Inlet:	1/4" BSP(F) / NPT
Temperature Limits:	Determined by Elastomers
Suction Lift (Dry):	4.6 m. (15.1')
Suction Lift (Wet):	6.1 m. (20')
Fluid Inlet/Outlet:	1" RJT (Standard)
Installation:	Wall or surface mounted
Accessories Included:	Exhaust air Silencer

Shipping Weights:

Stainless Steel/Aluminum	10.5 kg. (23.1 lbs.)
Stainless Steel	15.8 kg. (34.8 lbs.)

Shipping Dimensions: 320 x 210 x 390 mm.
(12.6" x 8.3" x 15.4")

Performance Curve

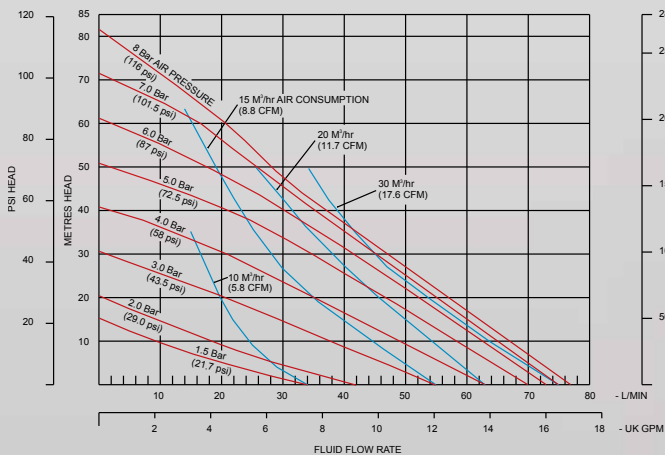

Note: The above Performance Curve has been determined under the following conditions: flooded suction, pumping clean water through a calibrated electronic flow meter with pulsation dampener and silencer fitted.

Dimensions

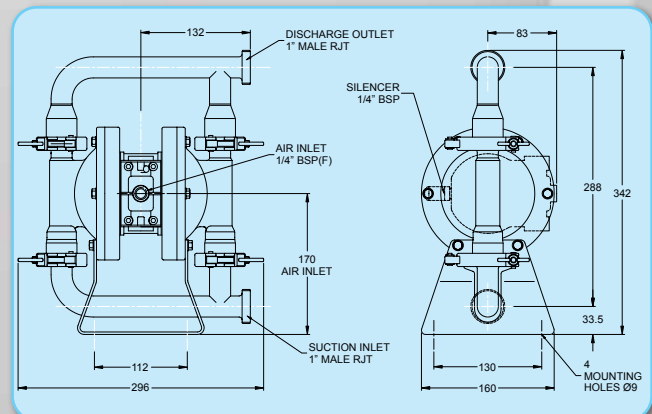

- Material options suitable for a wide range of chemicals
- Simple construction, easy to maintain
- Self priming, ideal for emptying containers
- Pressures to 8 bar (116 PSI)
- Flow rates up to 152 litres/minute (40 gal/min)
- Flanged or screwed end connections
- Reliable, pneumatic air valve
- Strong, robust design, bolted construction

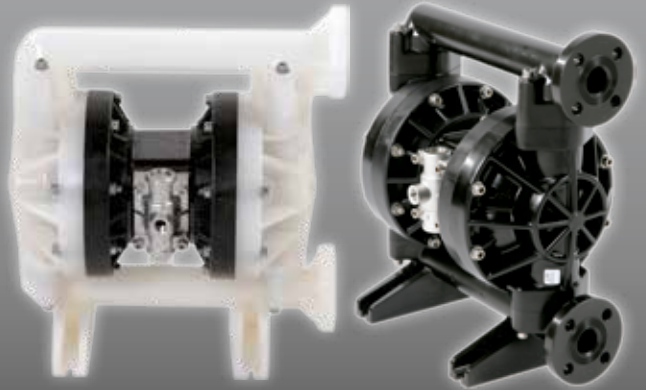

Typical Code = B25. 05. PT. BB. EEP -LF

MODEL - B25: Standard
X25: ATEX Compliant

DESIGN LEVEL

WETTED COMPONENTS
P: POLYPROPYLENE
K: KYNAR (PVDF)
G: CONDUCTIVE POLYPROPYLENE

NON-WETTED COMPONENTS
T: ALUMINUM / EPOXY PAINTED
W: STAINLESS STEEL/EPOXY PAINTED

VALVE TYPE
B: BALL
W: WEIGHTED

SUCTION ORIENTATION
B: BOTTOM

LUBE FREE

VALVE SEATS
B: BUNA-N
K: KYNAR (PVDF)
P: POLYPROPYLENE
N: NEOPRENE

VALVE BALLS
B: BUNA-N T: PTFE
E: EPDM V: VITON
N: NEOPRENE
S: STAINLESS STEEL

DIAPHRAGMS
B: BUNA-N
E: EPDM
N: NEOPRENE
R: SANTOPRENE
O: ONE PIECE PTFE
T: PTFE
V: VITON

Technical Data

MOULDED NON-METALLIC SERIES B25 POLYPROPYLENE & PVDF

Maximum Delivery:	152 ltrs/min (40 gal/min)
Max. Working Pressure:	8 bar (116 PSI)
Max. Solid Particle Size:	3 mm. (0.12")
Air Inlet:	3/8" BSP(F) / NPT
Temperature Limits:	Determined by Elastomers
Suction Lift (Dry):	6.1 m. (20')
Suction Lift (Wet):	7.6 m. (24.9')
Fluid Inlet/Outlet:	1" ANSI #150 Flanged RF
Installation:	Wall or surface mounted
Accessories Included:	Exhaust air Silencer

Shipping Weights:

Polypropylene/Aluminum	13.5 kg. (29.8 lbs.)
PVDF/Aluminum	18 kg. (39.7 lbs.)
Polypropylene/Stainless Steel	18 kg. (39.7 lbs.)
PVDF/Stainless Steel	20 kg. (44.1 lbs.)

Shipping Dimensions: 440 x 260 x 470 mm.
(17.3" x 10.2" x 18.5")

Performance Curve

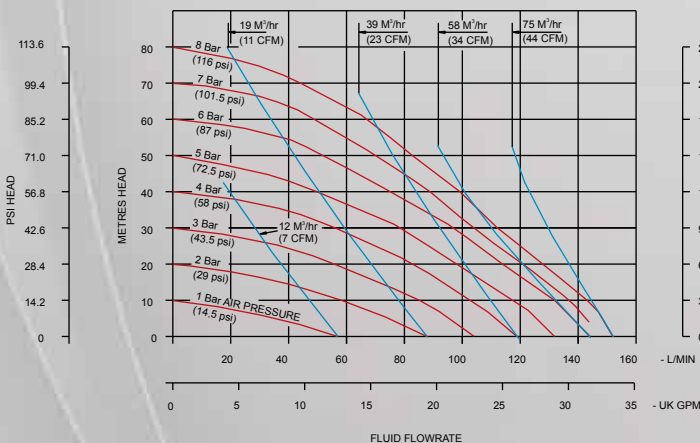

Dimensions

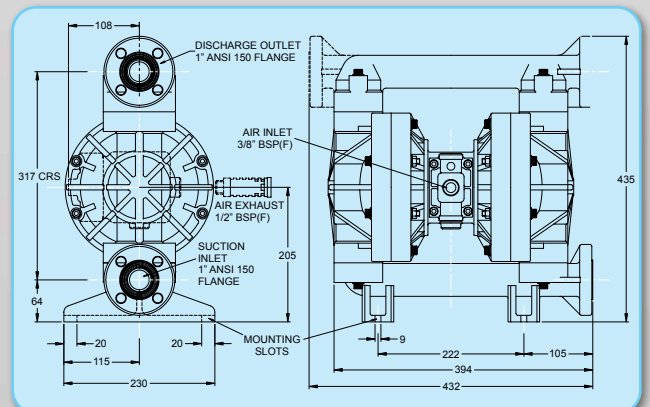

Note: The above Performance Curve has been determined under the following conditions: flooded suction, pumping clean water through a calibrated electronic flow meter with pulsation dampener and silencer fitted.

- Material options suitable for a wide range of applications
- Simple construction, easy to maintain
- Self priming, ideal for emptying containers
- Pressures to 8.6 bar (125 PSI)
- Flow rates up to 180 litres/minute (48 gal/min)
- Bolted construction for greater integrity
- Weighted Valve Balls for high S.G. and viscous fluids
- Reliable, pneumatic air valve



Typical Code = B25. 05. AA. BB. BBS -LF

MODEL - B25: Standard
X25: ATEX Compliant

DESIGN LEVEL

WETTED COMPONENTS

A: ALUMINUM
S: 316L STAINLESS STEEL
C: CAST IRON

NON-WETTED COMPONENTS

A: ALUMINUM
S: 316L STAINLESS STEEL

VALVE TYPE

B: BALL
W: WEIGHTED

SUCTION ORIENTATION

B: BOTTOM

LUBE FREE

VALVE SEATS

S: 316 STAINLESS STEEL

VALVE BALLS

B: BUNA-N T: PTFE
E: EPDM V: VITON
N: NEOPRENE D: DELRIN
S: 316 STAINLESS STEEL

DIAPHRAGMS

B: BUNA-N
P: POLYURETHANE
E: EPDM
R: SANTROPENE
H: POLYESTER T: PTFE
N: NEOPRENE V: VITON
O: ONE PIECE PTFE

Technical Data

METALLIC SERIES B25 ALUMINUM, STAINLESS STEEL, CAST IRON

Maximum Delivery:	180 ltrs/min (48 gal/min)
Max. Working Pressure:	8.6 bar (125 PSI)
Max. Solid Particle Size:	3 mm. (0.12")
Air Inlet:	3/8" BSP(F) / NPT
Temperature Limits:	Determined by Elastomers
Suction Lift (Dry):	6.1 m. (20')
Suction Lift (Wet):	7.6 m. (24.9')
Fluid Inlet/Outlet:	1" BSP / NPT
Installation:	Wall or surface mounted
Accessories Included:	Exhaust air Silencer

Shipping Weights:

Aluminum	16 kg. (35.3 lbs.)
Cast Iron/Aluminum	25 kg. (55.1 lbs.)
Stainless Steel/Aluminum	25 kg. (55.1 lbs.)

Shipping Dimensions: 400 x 300 x 470 mm.
(15.8" x 11.8" x 18.5")

Performance Curve

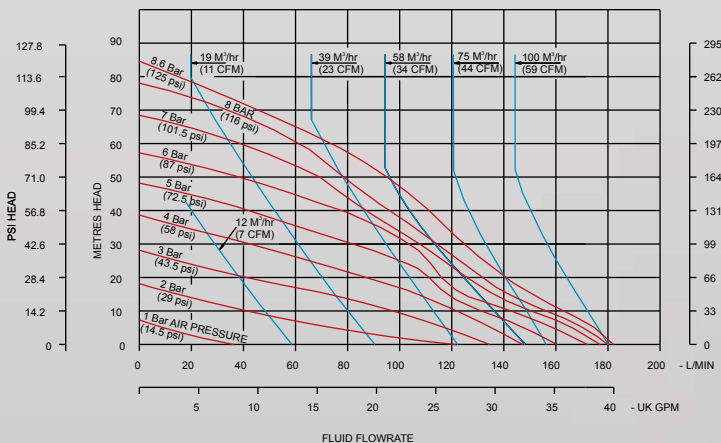

Note: The above Performance Curve has been determined under the following conditions: flooded suction, pumping clean water through a calibrated electronic flow meter with pulsation dampener and silencer fitted.

Dimensions

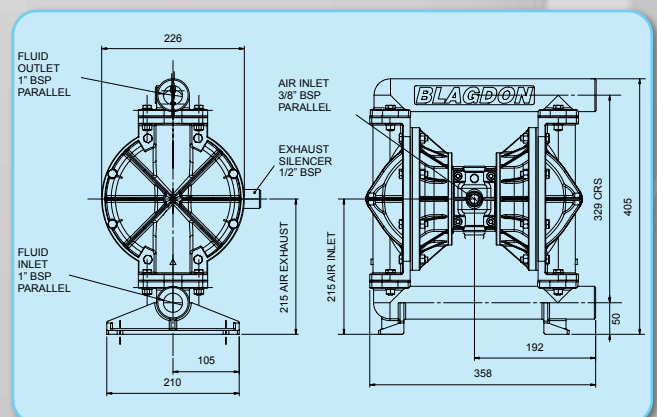

- Simple construction, easy to maintain
- Available in virgin and conductive PTFE
- Chemically inert
- Flanged end connections
- ATEX approved - intrinsically safe
- Reliable, proven pneumatic air valve
- Strong, robust design

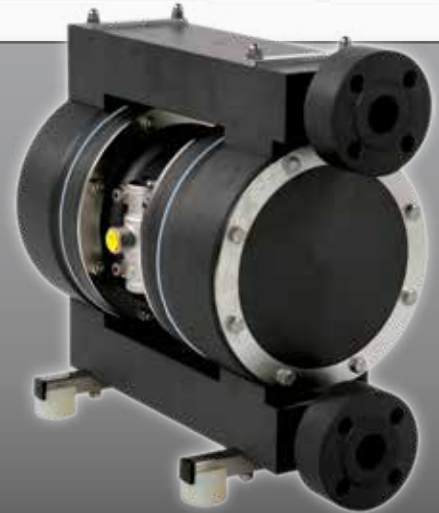

Typical Code = B25. 05. T5. BB. TTT -LF

MODEL - B25: Standard
X25: ATEX Compliant

DESIGN LEVEL

WETTED COMPONENTS

T: PTFE
4: CONDUCTIVE PTFE

NON-WETTED COMPONENTS

4: CONDUCTIVE PTFE
5: POLYETHYLENE (HDPE)

VALVE TYPE

B: BALL
W: WEIGHTED

SUCTION ORIENTATION

B: BOTTOM

LUBE FREE

VALVE SEATS

T: PTFE

VALVE BALLS

T: PTFE

DIAPHRAGMS

T: PTFE
X: PTFE/MITON (HIGH TEMP.)

Technical Data

NON-METALLIC SERIES B25 CONDUCTIVE / VIRGIN PTFE

Maximum Delivery:	136 ltrs/min (36 gal/min)
Max. Working Pressure:	7 bar (102 PSI)
Max. Solid Particle Size:	3 mm. (0.12")
Air Inlet:	3/8" BSP(F) / NPT
Temperature Limits:	Determined by Elastomers
Suction Lift (Dry):	6.1 m. (20')
Suction Lift (Wet):	7.6 m. (24.9')
Fluid Inlet/Outlet:	1" BSP / ANSI #150 Flange
Installation:	Wall or surface mounted
Accessories Included:	Exhaust air Silencer

Shipping Weights:

Conductive PTFE	40 kg. (88.2 lbs.)
Virgin PTFE	37 kg. (81.6 lbs.)

Shipping Dimensions: 500 x 300 x 450 mm.
(19.7" x 11.8" x 17.7")

*X Series ATEX pumps are ONLY applicable to Conductive PTFE pumps.

Performance Curve

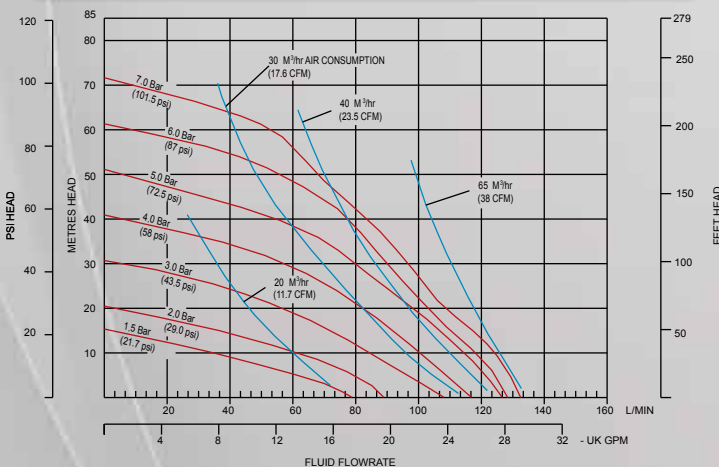

Note: The above Performance Curve has been determined under the following conditions: flooded suction, pumping clean water through a calibrated electronic flow meter with pulsation dampener and silencer fitted.

Dimensions

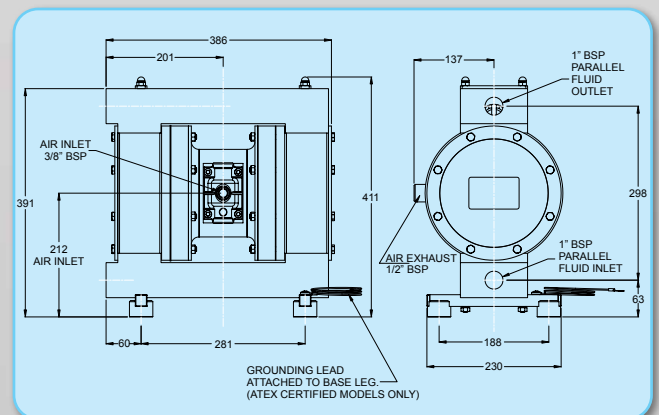

- Robust construction, easy to maintain
- Can easily handle viscous, high S.G. and high head applications
- Smooth action, less vibration and wear
- Pressures to 16 bar (232 PSI)
- Flow rates up to 125 litres/minute (33 gal/min)
- Bolted construction for greater integrity
- Reliable pneumatic air valve
- Stalls against closed head without damage
- Re-start on demand



Typical Code = B25. 05. AA. W3. NNS

MODEL - B25
X25: ATEX Compliant

DESIGN LEVEL

WETTED COMPONENTS
A: ALUMINUM
S: 316 STAINLESS STEEL

NON-WETTED COMPONENTS
A: ALUMINUM

VALVE TYPE
B: BALL
W: WEIGHTED

MODEL DESIGNATION

VALVE SEATS
S: 316 STAINLESS STEEL

VALVE BALLS
T: PTFE
N: NEOPRENE
B: BUNA-N

DIAPHRAGMS
T: PTFE
N: NEOPRENE
B: BUNA-N
R: SANTOPRENE

Technical Data

METALLIC SERIES FULL FLOW 2:1 B25

Maximum Delivery:	125 ltrs/min (33 gal/min)
Max. Working Pressure:	16 bar (232 PSI)
Max. Solid Particle Size:	3 mm. (0.12")
Air Inlet:	3/8" BSP(F) / NPT
Temperature Limits:	Determined by Elastomers
Suction Lift (Dry):	6 m. (20')
Suction Lift (Wet):	7.6 m. (24.9')
Fluid Inlet/Outlet:	1" BSP / NPT
Installation:	Surface mounted
Accessories Included:	Exhaust air Silencer

Shipping Weights:

Stainless Steel/Aluminum	33 kg. (72.8 lbs.)
Aluminum	24.5 kg. (54 lbs.)

Shipping Dimensions: 480 x 320 x 480 mm.
(18.9" x 12.6" x 18.9")

Performance Curve

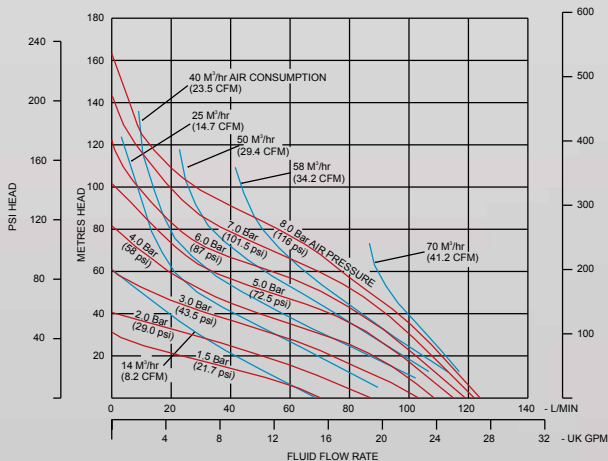

Note: The above Performance Curve has been determined under the following conditions: flooded suction, pumping clean water through a calibrated electronic flow meter with pulsation dampener and silencer fitted.

Dimensions

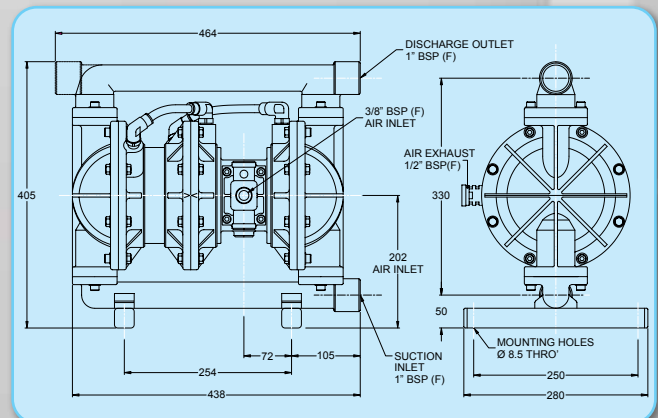

- Range of DIN/RJT and Ferrule connections
- Self priming, ideal for emptying containers
- Food grade elastomers-EPDM/PTFE
- Pressures to 8.6 bar (125 PSI)
- Capable of handling high viscosity & S.G.
- 316L Stainless Steel



Typical Code = B25. 05. ZF. BB. EEE -LF

MODEL - B25: Standard
X25: ATEX Compliant

DESIGN LEVEL

WETTED COMPONENTS
Z: 316 STAINLESS STEEL
(ELECTRO POLISHED)

NON-WETTED COMPONENTS
S: 316 STAINLESS STEEL
F: NICKEL PLATED ALUMINUM

VALVE TYPE
B: BALL

SUCTION ORIENTATION
B: BOTTOM

LUBE FREE

VALVE SEATS
S: 316 STAINLESS STEEL

VALVE BALLS
T: PTFE
S: 316 STAINLESS STEEL

DIAPHRAGMS
E: FOOD GRADE EPDM
O: ONE PIECE PTFE

Technical Data

HYGIENIC SERIES B25 STAINLESS STEEL

Maximum Delivery:	136 ltrs/min (36 gal/min)
Max. Working Pressure:	8.6 bar (125 PSI)
Max. Solid Particle Size:	5 mm. (0.2")
Air Inlet:	3/8" BSP(F) / NPT
Temperature Limits:	Determined by Elastomers
Suction Lift (Dry):	4.6 m. (15.1')
Suction Lift (Wet):	6.1 m. (20')
Fluid Inlet/Outlet:	1" RJT
Installation:	Wall or surface mounted
Accessories Included:	Exhaust air Silencer

Shipping Weights:

Stainless Steel 21.5 kg. (47.4 lbs.)

Shipping Dimensions: 450 x 280 x 500 mm.
(17.7" x 11" x 19.7")

Performance Curve

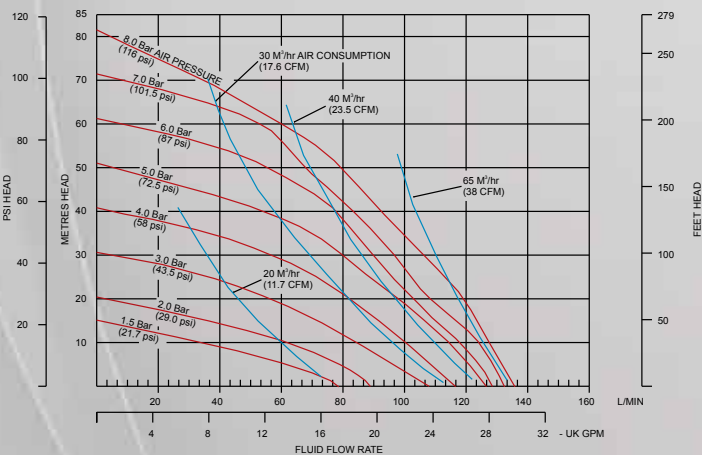

Note: The above Performance Curve has been determined under the following conditions: flooded suction, pumping clean water through a calibrated electronic flow meter with pulsation dampener and silencer fitted.

Dimensions

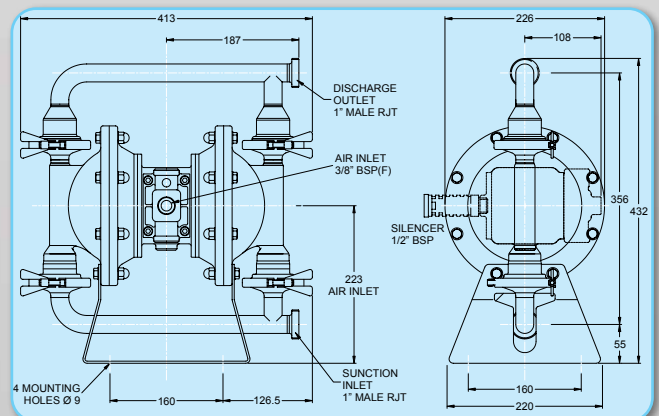

- Simple construction, easy to maintain
- Self priming, ideal for emptying containers
- Pressures to 8.6 bar (125 PSI)
- Flow rates up to 320 litres/minute (85 gal/min)
- Bolted construction for greater integrity
- Reliable, proven pneumatic air valve system



Typical Code = B40. 05. AA. BB. BBS -LF

MODEL - B40: Standard
X40: ATEX Compliant

DESIGN LEVEL

WETTED COMPONENTS

A: ALUMINUM
C: CAST IRON
S: 316L STAINLESS STEEL

NON-WETTED COMPONENTS

A: ALUMINUM
C: CAST IRON
S: 316L STAINLESS STEEL

VALVE TYPE

B: BALL
W: WEIGHTED

SUCTION ORIENTATION

B: BOTTOM

LUBE FREE

VALVE SEATS

B: BUNA-N A: ALUMINUM
E: EPDM V: VITON
N: NEOPRENE
S: 316 STAINLESS STEEL

VALVE BALLS

B: BUNA-N T: PTFE
E: EPDM V: VITON
N: NEOPRENE
S: 316 STAINLESS STEEL

DIAPHRAGMS

B: BUNA-N
P: POLYURETHANE
E: EPDM
R: SANTROPENE
H: POLYESTER T: PTFE
N: NEOPRENE V: VITON
O: ONE PIECE PTFE

*Pumps with cast iron wetted components are supplied at design level 01.

Technical Data

METALLIC SERIES B40 ALUMINUM, CAST IRON, STAINLESS STEEL

Maximum Delivery:	320 ltrs/min (85 gal/min)
Max. Working Pressure:	8.6 bar (125 PSI)
Max. Solid Particle Size:	6 mm. (0.24")
Air Inlet:	3/8" BSP(F) / NPT
Temperature Limits:	Determined by Elastomers
Suction Lift (Dry):	6.1 m. (20')
Suction Lift (Wet):	7.6 m. (24.9')
Fluid Inlet/Outlet:	1 1/2" BSP / NPT
Installation:	Surface mounted
Accessories Included:	Exhaust air Silencer

Shipping Weights:

Aluminum	22 kg. (48.5 lbs.)
Stainless Steel/Aluminum	36 kg. (79.4 lbs.)
Stainless Steel	46 kg. (101.4 lbs.)
Stainless Steel/Cast Iron	46 kg. (101.4 lbs.)
Cast Iron/Aluminum	51.4 kg. (113.3 lbs.)
Cast Iron	61 kg. (134.5 lbs.)

Shipping Dimensions: 500 x 350 x 600 mm.
(19.7" x 13.8" x 23.6")

Performance Curve

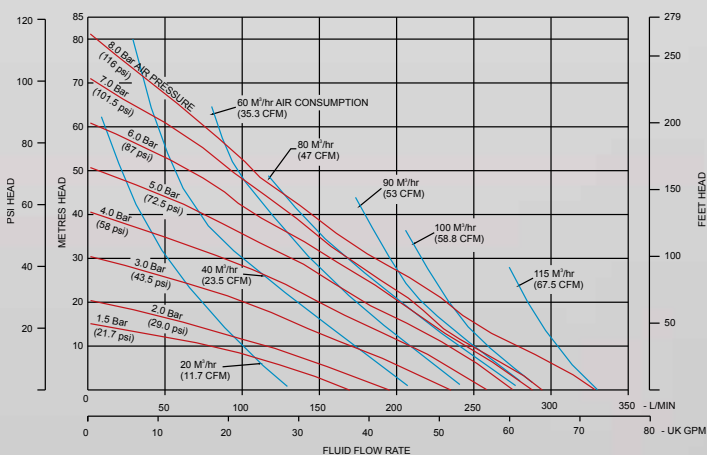

Note: The above Performance Curve has been determined under the following conditions: flooded suction, pumping clean water through a calibrated electronic flow meter with pulsation dampener and silencer fitted.

Dimensions

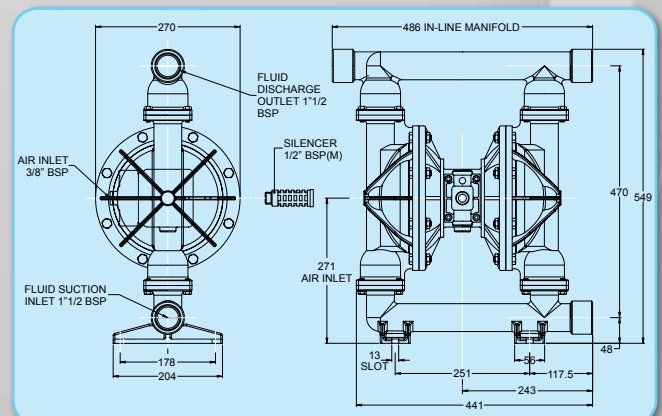

The above drawing shows Aluminum and Cast Iron only.

- Simple construction, easy to maintain
- Capable of handling high S.G. and viscous fluids
- Pressures to 8.6 bar (125 PSI)
- Flow rates up to 530 litres/minute (140 gal/min)
- Flanged end connections
- Reliable, proven pneumatic air valve

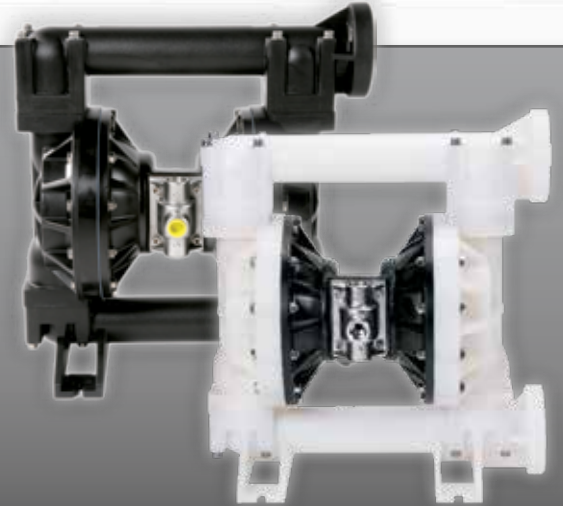

Typical Code = B50. 05. PT. BB. EEP -LF

MODEL - B50: Standard
X50: ATEX Compliant

DESIGN LEVEL

WETTED COMPONENTS
P: POLYPROPYLENE
K: KYNAR (PVDF)
G: CONDUCTIVE POLYPROPYLENE

NON-WETTED COMPONENTS
T: ALUMINUM / EPOXY PAINTED
W: STAINLESS STEEL / EPOXY PAINTED

VALVE TYPE
B: BALL
W: WEIGHTED

SUCTION ORIENTATION
B: BOTTOM

LUBE FREE

VALVE SEATS
B: BUNA-N T: PTFE
E: EPDM V: VITON
N: NEOPRENE
P: POLYPROPYLENE

VALVE BALLS
B: BUNA-N T: PTFE
E: EPDM V: VITON
N: NEOPRENE
S: 316 STAINLESS STEEL

DIAPHRAGMS
B: BUNA-N T: PTFE
E: EPDM V: VITON
H: POLYESTER (HYTREL)
N: NEOPRENE
P: POLYURETHANE
R: SANTOPRENE
O: ONE PIECE PTFE

*X Series ATEX pumps are ONLY applicable to Conductive Polypropylene pumps.

Technical Data

MOULDED NON-METALLIC SERIES B50 POLYPROPYLENE & PVDF

Maximum Delivery:	530 ltrs/min (140 gal/min)
Max. Working Pressure:	8.6 bar (125 PSI)
Max. Solid Particle Size:	6 mm. (0.24")
Air Inlet:	3/4" BSP(F) / NPT
Temperature Limits:	Determined by Elastomers
Suction Lift (Dry):	6.1 m. (20')
Suction Lift (Wet):	7.6 m. (24.9')
Fluid Inlet/Outlet:	2" ANSI #150 Flanged RF
Installation:	Surface mounted
Accessories Included:	Exhaust air Silencer

Shipping Weights:

Polypropylene/Aluminum	39.5 kg. (87.1 lbs.)
PVDF/Aluminum	50.5 kg. (111.3 lbs.)
Polypropylene/Stainless Steel	50.5 kg. (111.3 lbs.)
PVDF/Stainless Steel	70 kg. (154.3 lbs.)

Shipping Dimensions: 630 x 380 x 670 mm.
(24.8" x 15" x 26.4")

Performance Curve

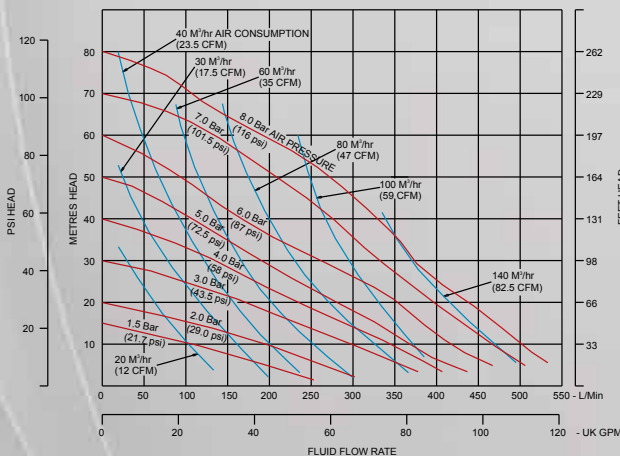

Note: The above Performance Curve has been determined under the following conditions: flooded suction, pumping clean water through a calibrated electronic flow meter with pulsation dampener and silencer fitted.

Dimensions

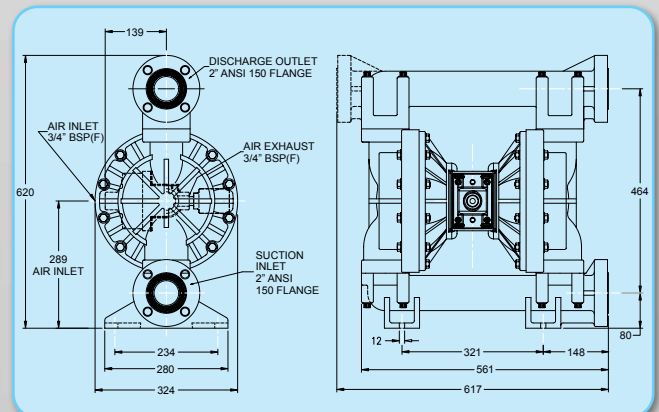

- Air valve designed for in-line maintenance
- End ported for improved flow
- Pressures to 8.6 bar (125 PSI)
- Flow rates up to 530 litres/minute (140 gal/min)
- Bolted construction for greater integrity
- Robust construction



Typical Code = B50. 05. AA. BB. BBB -LF

**MODEL - B50: Standard
X50: ATEX Compliant**

DESIGN LEVEL

WETTED COMPONENTS

A: ALUMINUM
C: CAST IRON

NON-WETTED COMPONENTS

A: ALUMINUM
C: CAST IRON

VALVE TYPE

B: BALL
W: WEIGHTED

SUCTION ORIENTATION

B: BOTTOM

LUBE FREE

VALVE SEATS

B: BUNA-N A: ALUMINUM
E: EPDM T: PTFE
N: NEOPRENE
S: 316 STAINLESS STEEL

VALVE BALLS

B: BUNA-N T: PTFE
E: EPDM V: VITON
N: NEOPRENE
S: 316 STAINLESS STEEL

DIAPHRAGMS

B: BUNA-N
P: POLYURETHANE
E: EPDM
R: SANTROPENE
H: POLYESTER T: PTFE
N: NEOPRENE V: VITON
O: ONE PIECE PTFE

Technical Data

METALLIC SERIES B50 ALUMINUM & CAST IRON

Maximum Delivery:	530 ltrs/min (140 gal/min)
Max. Working Pressure:	8.6 bar (125 PSI)
Max. Solid Particle Size:	6 mm. (0.24")
Air Inlet:	3/4" BSP(F) / NPT
Temperature Limits:	Determined by Elastomers
Suction Lift (Dry):	6.1 m. (20')
Suction Lift (Wet):	7.6 m. (24.9')
Fluid Inlet/Outlet:	2" BSP / NPT
Installation:	Surface mounted
Accessories Included:	Exhaust air Silencer

Shipping Weights:

Aluminum	38 kg. (83.8 lbs.)
Cast Iron/Aluminum	63 kg. (138.9 lbs.)
Cast Iron	90 kg. (198.4 lbs.)

Shipping Dimensions: 540 x 350 x 750 mm.
(12.3" x 13.8" x 29.5")

Performance Curve

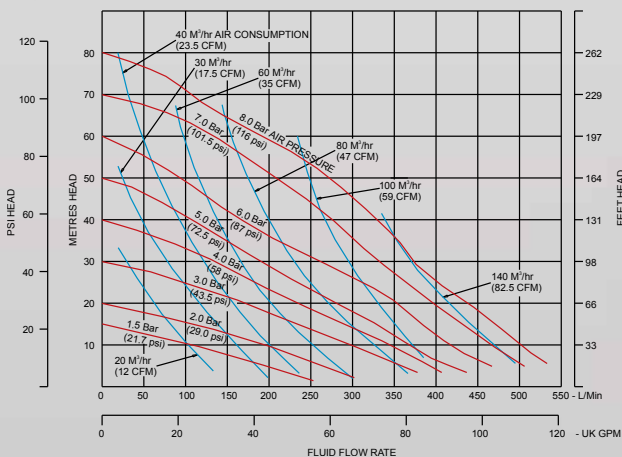

Note: The above Performance Curve has been determined under the following conditions: flooded suction, pumping clean water through a calibrated electronic flow meter with pulsation dampener and silencer fitted.

Dimensions

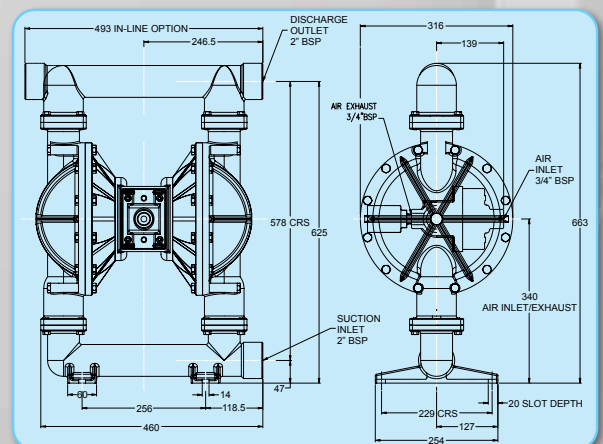

- Simple construction, easy to maintain
- Self priming, ideal for emptying containers
- Pressures to 8.6 bar (125 PSI)
- Flow rates up to 530 litres/minute (140 gal/min)
- Bolted construction for greater integrity
- 316 stainless steel



Typical Code = B50. 05. SA. BB. BBS -LF

MODEL - B50: Standard
X50: ATEX Compliant

DESIGN LEVEL

WETTED COMPONENTS
S: 316L STAINLESS STEEL

NON-WETTED COMPONENTS
A: ALUMINUM
S: 316L STAINLESS STEEL

VALVE TYPE
B: BALL
W: WEIGHTED

SUCTION ORIENTATION
B: BOTTOM

LUBE FREE

VALVE SEATS
B: BUNA-N A: ALUMINUM
E: EPDM V: VITON
N: NEOPRENE
S: 316 STAINLESS STEEL

VALVE BALLS
B: BUNA-N T: PTFE
E: EPDM V: VITON
N: NEOPRENE
S: 316 STAINLESS STEEL

DIAPHRAGMS
B: BUNA-N
P: POLYURETHANE
E: EPDM
R: SANTROPENE
H: POLYESTER T: PTFE
N: NEOPRENE

Technical Data

METALLIC SERIES B50 STAINLESS STEEL

Maximum Delivery:	530 ltrs/min (140 gal/min)
Max. Working Pressure:	8.6 bar (125 PSI)
Max. Solid Particle Size:	6 mm. (0.24")
Air Inlet:	3/4" BSP(F) / NPT
Temperature Limits:	Determined by Elastomers
Suction Lift (Dry):	6.1 m. (20')
Suction Lift (Wet):	7.6 m. (24.9')
Fluid Inlet/Outlet:	2" BSP / NPT
Installation:	Surface mounted
Accessories Included:	Exhaust air Silencer

Shipping Weights:

Stainless Steel/Aluminum	70 kg. (154.3 lbs.)
Stainless Steel	95.5 kg. (210.5 lbs.)
Stainless Steel/Cast Iron	95.5 kg. (210.5 lbs.)

Shipping Dimensions: 630 x 380 x 670 mm.
(24.8" x 15" x 26.4")

Performance Curve

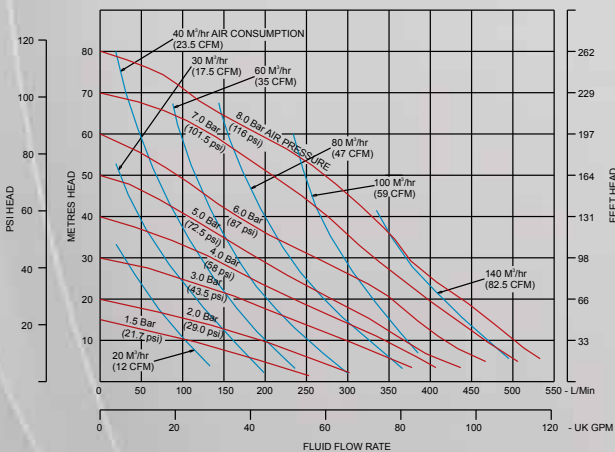

Note: The above Performance Curve has been determined under the following conditions: flooded suction, pumping clean water through a calibrated electronic flow meter with pulsation dampener and silencer fitted.

Dimensions

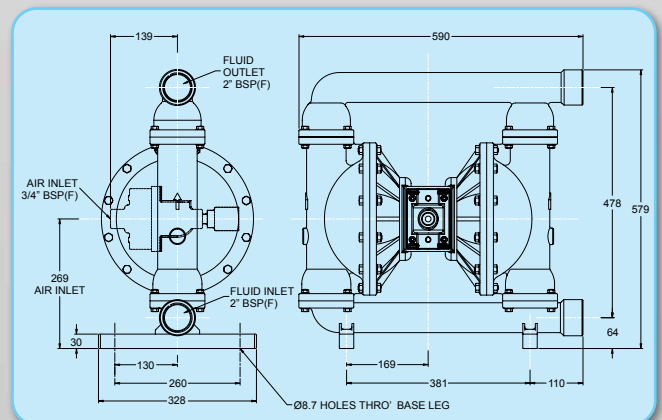

- Robust construction, easy to maintain
- Can easily handle viscous, high S.G. and high head applications
- Smooth action, less vibration and wear
- Pressures to 16 bar (232 PSI)
- Flow rates up to 350 litres/minute (92 gal/min)
- Bolted construction for greater integrity
- Reliable pneumatic air valve
- Stalls against closed head without damage
- Re-start on demand



Typical Code = B50. 05. SA. W3. BBS

MODEL - B50: Standard
X50: ATEX Compliant

DESIGN LEVEL

WETTED COMPONENTS
A: ALUMINUM
S: 316 STAINLESS STEEL

NON-WETTED COMPONENTS
A: ALUMINUM

VALVE TYPE
B: BALL
W: WEIGHTED

MODEL DESIGNATION

VALVE SEATS
S: 316 STAINLESS STEEL
A: ALUMINUM

VALVE BALLS
T: PTFE
N: NEOPRENE
B: BUNA-N
E: EPDM
S: STAINLESS STEEL
V: VITON

DIAPHRAGMS
T: PTFE
N: NEOPRENE
B: BUNA-N
R: SANTOPRENE
E: EPDM
H: POLYESTER (HYTREL)
P: POLYURETHANE
V: VITON

Technical Data

METALLIC SERIES- FULL FLOW 2:1 B50 STAINLESS STEEL, ALUMINUM

Maximum Delivery:	350 ltrs/min (92 gal/min)
Max. Working Pressure:	16 bar (232 PSI)
Max. Solid Particle Size:	6 mm. (0.24")
Air Inlet:	3/4" BSP(F) / NPT
Temperature Limits:	Determined by Elastomers
Suction Lift (Dry):	6.1 m. (20')
Suction Lift (Wet):	7.6 m. (24.9')
Fluid Inlet/Outlet:	2" BSP / NPT
Installation:	Surface mounted
Accessories Included:	Exhaust air Silencer

Shipping Weights:

Stainless Steel/Aluminum	78 kg. (172 lbs.)
Aluminum	52 kg. (114.6 lbs.)

Shipping Dimensions: 850 x 450 x 800 mm.
(33.5" x 17.7" x 31.5")

Performance Curve

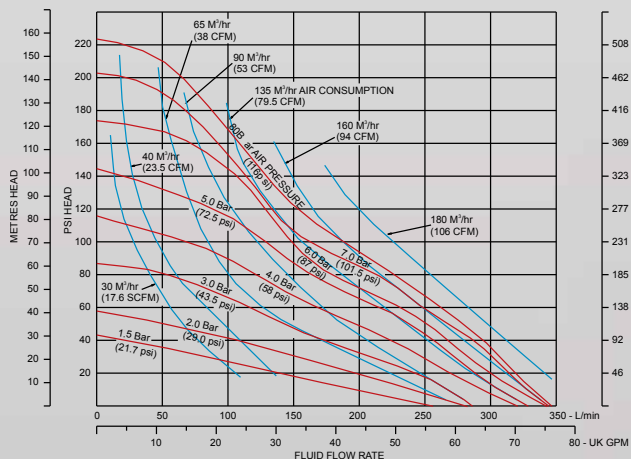

Note: The above Performance Curve has been determined under the following conditions: flooded suction, pumping clean water through a calibrated electronic flow meter with pulsation dampener and silencer fitted.

Dimensions

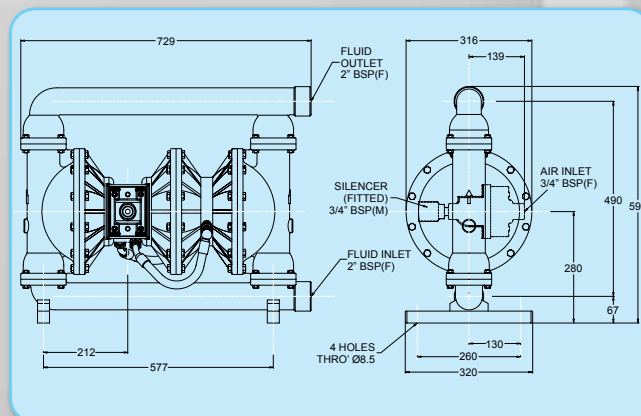

The above drawing shows Stainless Steel only.

- Range of DIN/RJT and ferrule connections
- Self priming, ideal for emptying containers
- Food grade elastomers-EPDM/PTFE
- Pressures to 8.6 bar (125 PSI)
- Capable of handling high viscosity & S.G.
- 316L Stainless Steel
- Pump stand option for 180° rotation in place



Typical Code = B50. 05. ZF. BB. EEE -LF

MODEL - B50: Standard
X50: ATEX Compliant

DESIGN LEVEL

WETTED COMPONENTS
Z: 316 STAINLESS STEEL
(ELECTRO POLISHED)

NON-WETTED COMPONENTS
S: 316 STAINLESS STEEL
F: NICKEL PLATED ALUMINUM

VALVE TYPE
B: BALL

SUCTION ORIENTATION
B: BOTTOM

LUBE FREE

VALVE SEATS
E: FOOD GRADE EPDM
T: PTFE

VALVE BALLS
E: FOOD GRADE EPDM
T: PTFE
S: 316 STAINLESS STEEL

DIAPHRAGMS
E: FOOD GRADE EPDM
O: ONE PIECE PTFE

Technical Data

HYGIENIC SERIES B50 STAINLESS STEEL

Maximum Delivery:	500 ltrs/min (132 gal/min)
Max. Working Pressure:	8.6 bar (125 PSI)
Max. Solid Particle Size:	10 mm. (0.39")
Air Inlet:	3/4" BSP(F) / NPT
Temperature Limits:	Determined by Elastomers
Suction Lift (Dry):	6.1 m. (20')
Suction Lift (Wet):	7.6 m. (24.9')
Fluid Inlet/Outlet:	2" RJT (Standard)
Installation:	Surface mounted
Accessories Included:	Exhaust air Silencer

Shipping Weight:

Stainless Steel 64 kg. (141.1 lbs.)

Shipping Dimensions: 660 x 430 x 880 mm.
(26" x 16.9" x 34.7")

Performance Curve

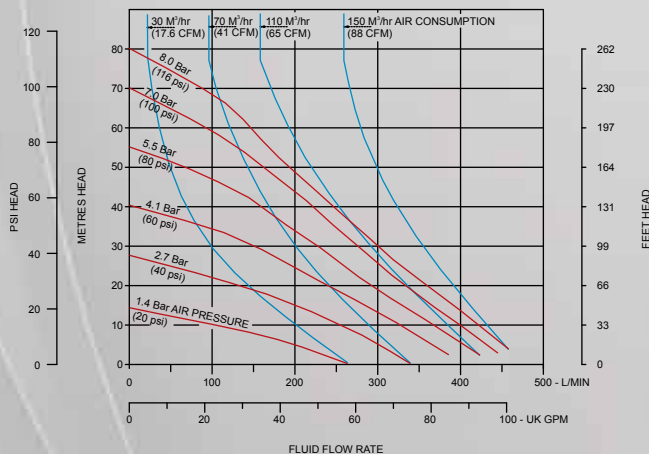

Note: The above Performance Curve has been determined under the following conditions: flooded suction, pumping clean water through a calibrated electronic flow meter with pulsation dampener and silencer fitted.

Dimensions

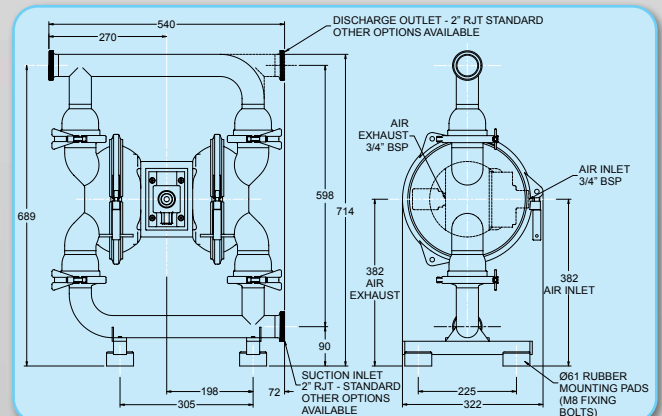

- Simple construction, easy to maintain
- Capable of handling high S.G. and viscous fluids
- Pressures to 7 bar (102 PSI)
- Flow rates up to 901 litres/minute (238 gal/min)
- Adjustable flanged connections
- Reliable, proven pneumatic air valve



Typical Code = B75. 03. PT. BB. TTP -LF

MODEL - B75: Standard

DESIGN LEVEL

WETTED COMPONENTS

P: POLYPROPYLENE
K: PVDF

NON-WETTED COMPONENTS

T: ALUMINUM / EPOXY PAINTED

VALVE TYPE

B: BALL
W: WEIGHTED

SUCTION ORIENTATION

B: BOTTOM

LUBE FREE

VALVE SEATS

P: POLYPROPYLENE
K: PVDF

VALVE BALLS

T: PTFE
R: SANTOPRENE

DIAPHRAGMS

T: PTFE
R: SANTOPRENE

Technical Data

MOULDED NON-METALLIC SERIES B75 POLYPROPYLENE & PVDF

Maximum Delivery:	901 ltrs/min (238 gal/min)
Max. Working Pressure:	7 bar (102 PSI)
Max. Solid Particle Size:	18 mm. (0.71")
Air Inlet:	3/4" BSP(F) / NPT
Temperature Limits:	Determined by Elastomers
Suction Lift (Dry):	5.1 m. (16.8')
Fluid Inlet/Outlet:	3" ANSI Flange
Installation:	Surface mounted
Accessories Included:	Exhaust air Silencer

Shipping Weights:

Polypropylene	105 kg. (231.5 lbs.)
PVDF	143 kg. (315.3 lbs.)

Shipping Dimensions: 558 x 965 x 1219 mm.
(22" x 38" x 48")

Performance Curve

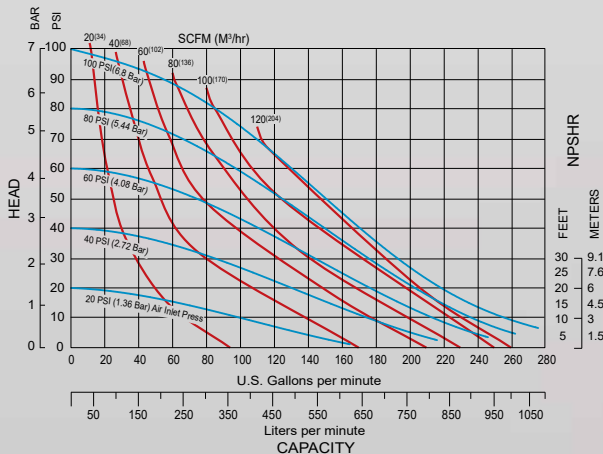

Note: The above Performance Curve has been determined under the following conditions: flooded suction, pumping clean water through a calibrated electronic flow meter with pulsation dampener and silencer fitted.

Dimensions

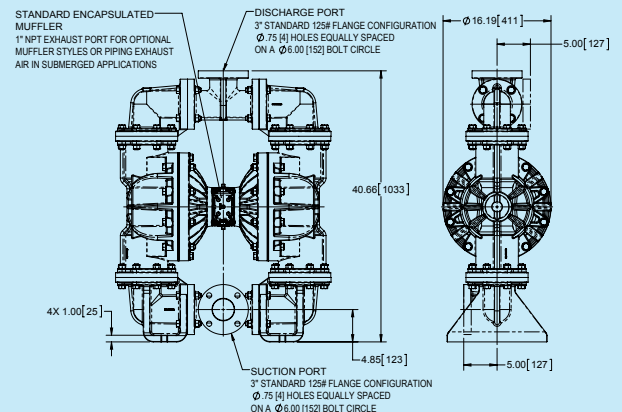

- Air valve will not stall in mid position
- Air valve designed for in-line maintenance
- Available as both end and center ported
- Pressures to 8.6 bar (125 PSI)
- Flow rates up to 889 litres/minute (234.8 gal/min)
- Bolted construction for greater integrity
- Robust construction



Typical Code = X75. 01. AA. BB. BBB

MODEL - X75: ATEX Certified

DESIGN LEVEL

WETTED COMPONENTS

A: ALUMINIUM
C: CAST IRON
S: STAINLESS STEEL

NON-WETTED COMPONENTS

A: ALUMINIUM
C: CAST IRON

VALVE TYPE

B: BALL
W: WEIGHTED

SUCTION ORIENTATION

B: BOTTOM

VALVE SEATS

B: BUNA-N A: ALUMINIUM
E: EPDM T: PTFE
N: NEOPRENE V: VITON
S: 316 STAINLESS STEEL

VALVE BALLS

B: BUNA-N
T: PTFE
E: EPDM
R: SANTOPRENE
N: NEOPRENE

DIAPHRAGMS

B: BUNA-N
V: VITON
E: EPDM
T: PTFE
N: NEOPRENE
R: SANTOPRENE

Technical Data

METALLIC SERIES X75

Maximum Delivery:	889 ltrs/min (234.8 gal/min)
Max. Working Pressure:	8.6 bar (125 PSI)
Max. Solid Particle Size:	9.65 mm. (0.38")
Air Inlet:	3/4" BSP(F) / NPT
Temperature Limits:	Determined by Elastomers
Suction Lift (Dry):	4 m. (13.1')
Fluid Inlet/Outlet:	3" BSP Tapered (End Ported - AL) DIN Flanged (Center Ported - CI, SS)
Installation:	Surface mounted
Accessories Included:	Exhaust air Silencer

Shipping Weights:

Aluminium	53.5 kg. (117.7 lbs.)
Cast Iron/Aluminum	90 kg. (198 lbs.)
Stainless Steel/Aluminum	90 kg. (198 lbs.)

Shipping Dimensions: 720 x 350 x 900 mm.
(28.3" x 13.8" x 35.4")

Performance Curve

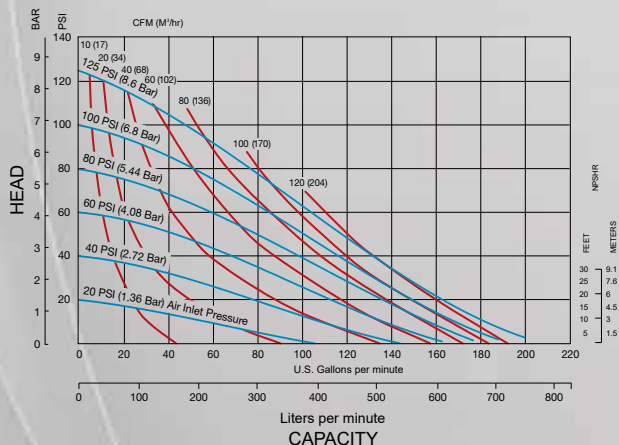

Note: The above Performance Curve has been determined under the following conditions: flooded suction, pumping clean water through a calibrated electronic flow meter with pulsation dampener and silencer fitted.

Dimensions

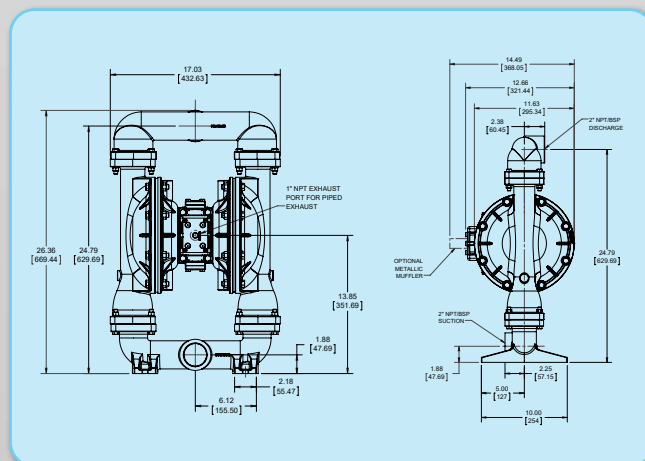

- Bottom discharge ported for efficient solids handling
- Air valve will not stall in mid position
- Air valve designed for in-line maintenance
- Pressures to 8.6 bar (125 PSI)
- Flow rates up to 265 litres/minute (70 gal/min)
- Bolted construction for greater integrity
- Flap Valve pump for line size solids handling



Typical Code = X25. 01. CC. FT. BBS

MODEL - X25: ATEX Certified

DESIGN LEVEL

WETTED COMPONENTS

A: ALUMINIUM
C: CAST IRON
S: STAINLESS STEEL

NON-WETTED COMPONENTS

A: ALUMINIUM
C: CAST IRON

VALVE TYPE

F: FLAP

SUCTION ORIENTATION

T: TOP

VALVE SEATS

S: STAINLESS STEEL

VALVE FLAPS

B: NITRILE
N: NEOPRENE
R: SANTOPRENE
P: POLYURETHANE
H: HYTREL
V: FKM
E: EPDM

DIAPHRAGMS

B: NITRILE
R: SANTOPRENE
N: NEOPRENE
V: VITON
E: EPDM
H: HYTREL

Technical Data

METALLIC SERIES X25

Maximum Delivery:	265 ltrs/min (70 gal/min)
Max. Working Pressure:	8.6 bar (125 PSI)
Max. Solid Particle Size:	25 mm. (0.98")
Air Inlet:	1/2" BSP(F) / NPT
Temperature Limits:	Determined by Elastomers
Suction Lift (Dry):	5.8 m. (19')
Fluid Inlet/Outlet:	1" BSP Tapered / NPT
Installation:	Surface mounted
Accessories Included:	Exhaust air Silencer

Shipping Weights:

Aluminium	21 kg. (46.3 lbs.)
Cast Iron	34 kg. (75 lbs.)
Stainless Steel	36 kg. (79.4 lbs.)

Shipping Dimensions: 381 x 457 x 482 mm.
(15" x 18" x 19")

Performance Curve

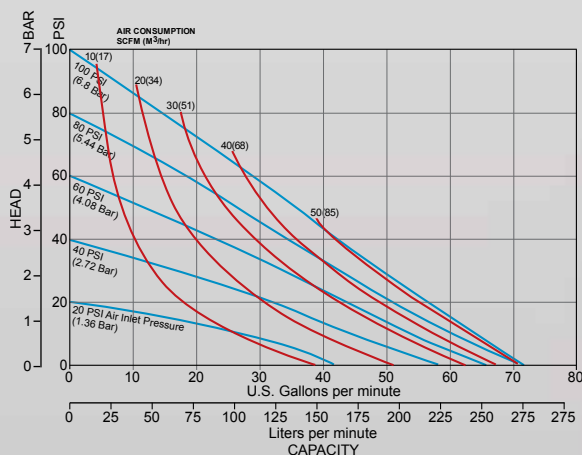

Note: The above Performance Curve has been determined under the following conditions: flooded suction, pumping clean water through a calibrated electronic flow meter with pulsation dampener and silencer fitted.

Dimensions

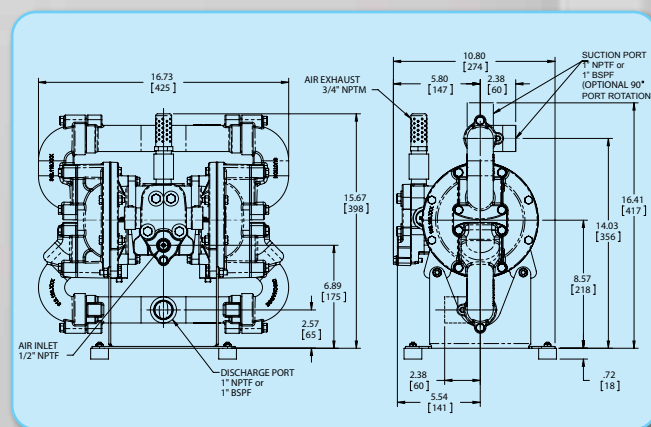

- Simple construction, easy to maintain
- Self priming, ideal for emptying containers
- High quality investment cast design
- Pressures to 8.6 bar (125 PSI)
- Flow rates up to 530 litres/minute (140 gal/min)
- Bolted construction for safety
- Reliable pneumatic air valve system



Typical Code = X50.01.CC.FT.BBS

MODEL - X50: ATEX Certified

DESIGN LEVEL

WETTED COMPONENTS

- A: ALUMINIUM
- C: CAST IRON
- S: STAINLESS STEEL

NON-WETTED COMPONENTS

- A: ALUMINIUM
- C: CAST IRON

VALVE TYPE

- F: FLAP

SUCTION ORIENTATION

- T: TOP

VALVE SEATS

- S: STAINLESS STEEL

VALVE FLAPS

- B: NITRILE
- N: NEOPRENE
- R: SANTOPRENE
- H: HYTREL
- P: POLYURETHANE
- V: FKM
- E: EPDM

DIAPHRAGMS

- B: NITRILE
- R: SANTOPRENE
- N: NEOPRENE
- E: EPDM
- V: FKM

Technical Data

METALLIC SERIES X50

Maximum Delivery:	530 ltrs/min (140 gal/min)
Max. Working Pressure:	8.6 bar (125 PSI)
Max. Solid Particle Size:	50 mm. (1.97")
Air Inlet:	3/4" BSP(F) / NPT
Temperature Limits:	Determined by Elastomers
Suction Lift (Dry):	7.3 m. (24')
Fluid Inlet/Outlet:	2" NPT
Installation:	Surface mounted
Accessories Included:	Exhaust air Silencer

Shipping Weights:

Aluminium	39 kg. (86 lbs.)
Cast Iron	76 kg. (167.6 lbs.)
Stainless Steel	76 kg. (167.6 lbs.)

Shipping Dimensions: 406 x 584 x 584 mm.
(16" x 23" x 23")

Performance Curve

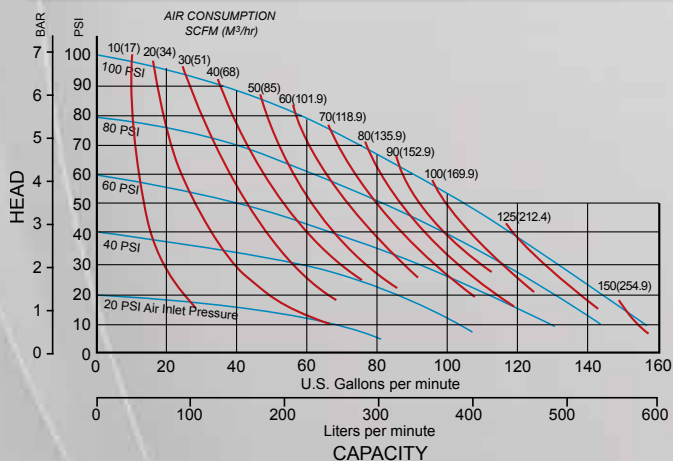

Note: The above Performance Curve has been determined under the following conditions: flooded suction, pumping clean water through a calibrated electronic flow meter with pulsation dampener and silencer fitted.

Dimensions

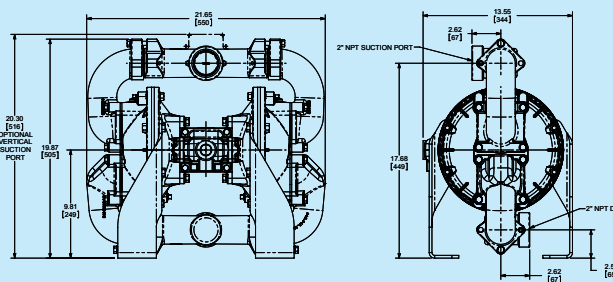

- Bottom discharge ported for efficient solids handling
- Air valve will not stall in mid position
- Air valve designed for in-line maintenance
- Pressures to 8.6 bar (125 PSI)
- Flow rates up to 998 litres/minute (264 gal/min)
- Bolted construction for greater integrity
- Robust construction

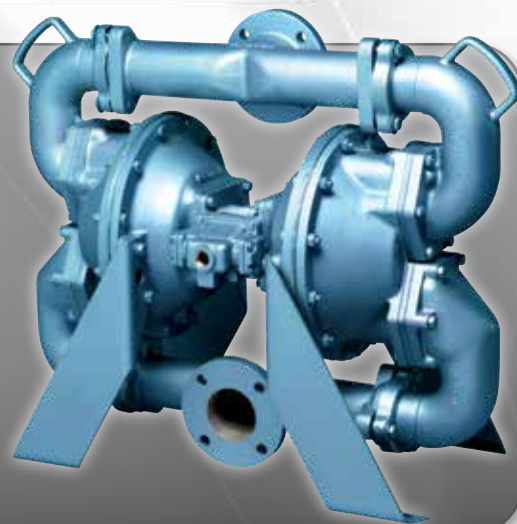

Typical Code = X75. 01. AA. FT. BBS

MODEL - X75: ATEX Certified

DESIGN LEVEL

WETTED COMPONENTS

A: ALUMINIUM
C: CAST IRON

NON-WETTED COMPONENTS

A: ALUMINIUM

VALVE TYPE

F: FLAP

SUCTION ORIENTATION

T: TOP

VALVE SEATS

S: STAINLESS STEEL

VALVE FLAPS

B: NITRILE
N: NEOPRENE
R: SANTOPRENE
H: HYTREL
P: POLYURETHANE

DIAPHRAGMS

B: NITRILE
R: SANTOPRENE
N: NEOPRENE

Technical Data

METALLIC SERIES X75

Maximum Delivery:	998 ltrs/min (264 gal/min)
Max. Working Pressure:	8.6 bar (125 PSI)
Max. Solid Particle Size:	75 mm. (3")
Air Inlet:	1/2" BSP(F) / NPT
Temperature Limits:	Determined by Elastomers
Suction Lift (Dry):	5.5 m. (18')
Fluid Inlet/Outlet:	3" ANSI Flange
Installation:	Surface mounted
Accessories Included:	Exhaust air Silencer

Shipping Weights:

Aluminium 92 kg. (202.8 lbs.)

Shipping Dimensions: 533 x 965 x 939 mm.
(21" x 38" x 37")

Performance Curve

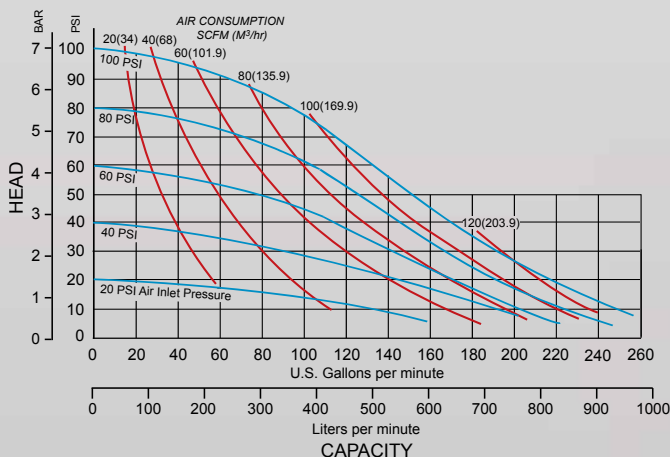

Dimensions

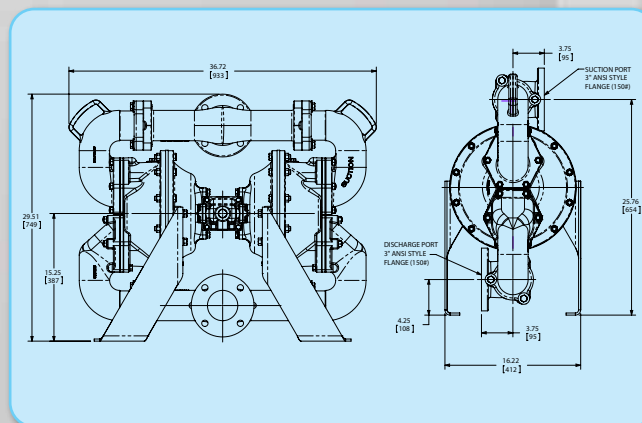

Note: The above Performance Curve has been determined under the following conditions: flooded suction, pumping clean water through a calibrated electronic flow meter with pulsation dampener and silencer fitted.



Pulsation Dampener

- Virtually pulsation free flows
- Steadier pressures
- Less vibration and noise
- Simple installation
- Variety of sizes and materials
- Automatically self changing



Flanges

- ANSI 150 as standard also available:
 - ANSI 300
 - PN16
 - Food Industry - RJT, DIN, TRI-CLAMP
- Ease of connections to pipework systems



Valve Block with Sensors

- Batch Control
- Linkage to control equipment
- Greater process control
- 10 - 30v DC, PNP normally open



Filter Regulators

- Maintains constant oil density with varying flow
- Remote installation for ease of maintenance
- Ensures clean, filtered air
- Can be controlled independently of other equipment





Visit Our Website Today



The purpose of our website is to have as much information as possible available to our customers.

Also shown within the web pages are:

- Chemical Resistance Charts
- Kit Revisions
- Index with Components and Drawings
- Viscosity Correction Curve
- Flow Rate Conversion Calculator
- Shipping Weights and Dimensions
- Blagdon Numbering System



Product Literature

Product specific literature is available which includes:

- Technical data
- Performance Curves
- Applicable industries/applications
- Available options



A large, rounded rectangular area containing 25 horizontal lines for writing notes.



BLAGDON PUMP

R79 Shannon Industrial Estate, Shannon, Co. Clare, Ireland
Phone: +353 (0) 61 471933 • Fax: +353 (0) 61 475046 • sales.blagdonpump@idexcorp.com

ASEAN COMMERCIAL OPERATIONS

IDEX Asia Pacific Pte Ltd

Mr. Morgan Lim
AODD Regional Sales Manager
18 Boon Lay Way #09-97/98
Tradehub 21
Singapore 609966
Email: mlim@idexcorp.com
Tel: 65-66847310
Mobile: 65-91698181

WEST ASIA COMMERCIAL OPERATIONS

IDEX India Pvt Ltd

Mr. Rohit Kalra
Sales Director
Sunteck Centre 3rd Floor,
37-40 Subhash Road,
Vile Parle East, Mumbai 400 057
India.
Email: rkalra@idexcorp.com
Tel: +91 22 6643 5534
Mobile: +91 11 65020172

CHINA OPERATIONS

IDEX CHINA

Mr. Leslie Zhang
Room 3502-3505, No.1027
Changning Road,
Zhaofeng Plaza, Shanghai,
China 200050
Email: LZhang2@idexcorp.com
Tel: +86 0215 241 5599
Mobile: +86 1500 077 6358

SOUTHERN AFRICA & OCEANIA REGIONS

Mr. Paul Vermaak
District Manager
Email: pvermaak@idexcorp.com
Tel: +27 (0)21 788 1975
Mobile: +27 (0)83 571 7021

Local Distributor



Distributors located globally – for channel partners please visit:

www.blagdonpump.com