



Aftermarket

SANDPIPER[®]
GENUINE PARTS

IBEX
CORPORATION

SANDPIPER®

Pumping Solutions

A WARREN RUPP, INC. BRAND

...with more ways than one



HEAVY DUTY BALL



CONTAINMENT DUTY

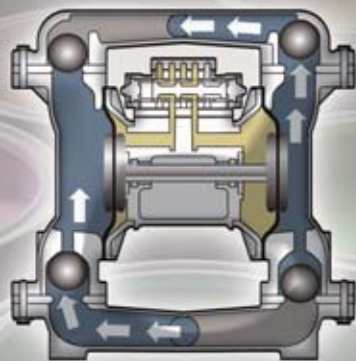

STANDARD DUTY

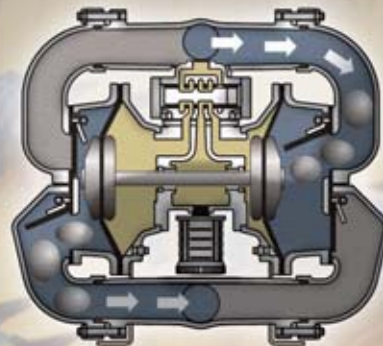

HEAVY DUTY FLAP

CERAMICS

CHEMICAL

COATINGS

MINING



 **AirVantage**
ENERGY SAVING TECHNOLOGY

AWARD WINNING
TECHNOLOGY
LEARN MORE ON PAGES 16-17

SANDPIPER®

A WARREN RUPP, INC. BRAND

Message to Our Customers...

Acknowledging the number of pump types commercially available throughout the world today, we are renewing our commitment to provide our customers with technically-sound equipment use, sizing, selection and application knowledge. Enabling representatives and customers to make better-informed choices has been a hallmark commitment from Warren Rupp, Inc. for the past 47 years.

While there are hundreds of pump types manufactured, most can be classified as either centrifugal or displacement, each having its own inherent design strengths and weaknesses. As a result, our company founder, Warren E. Rupp recognized limitations with a one-design-fits-all approach to solving difficult pumping problems. Thus, the non-positive displacement pump, the air (or natural gas) powered, double diaphragm SANDPIPER® pump range offers our customers a variety of unique problem solving Air-Operated Double Diaphragm (AODD) pump designs. Today, our core designs include heavy duty ball, heavy duty flap, containment duty and standard duty configurations.

While we acknowledge that even the most diverse range of AODD pump designs cannot solve all problems or fill the needs of every pumping application, there is no other pump type on the market today that is so universally applicable and so responsive to pumping problem fluids.

We are proud to introduce (or maybe even reintroduce) you to our SANDPIPER® Pump Solutions!

Warren Rupp, Inc. Team



TABLE OF CONTENTS

Solution Providing Advantages - AODD Pumps	4-5
Solution Providing Capabilities	6
Primary Markets Served	7
Signature Design Platform	8-9
Signature Configurations	10-11
Best Practices - AODD Selection and Sizing	12-15
Signature Configuration Features	16-25
AirVantage™ - Energy Saving Technology	16-17
Heavy Duty Ball	18-19
Heavy Duty Flap	20-21
Containment Duty Ball	22-23
Standard Duty Ball	24-25
Best Practices - Recommended Process Control Components	26-32
Accessories - Process Control Loop	28-29
Accessories - Tranquilizer® / Options	30-31
Accessories - Drum Pump	32
OEM Solutions / WR10 Pump	33
Signature Configuration Details	34-53
Heavy Duty Ball	34-37
Heavy Duty Flap	38-41
Containment Duty Ball	42-45
Standard Duty Ball (Metallic)	46-49
Standard Duty Ball (Non-Metallic)	50-53
Special Duty Configuration Details	54-69
High Pressure Duty Pumps	54
High Pressure Duty Blagdon Pumps	55
Filter Press Systems	56
Non-Clog Wastewater Pumps	57
Special Duty - UL (Underwriters Laboratory) Pump	58
Special Duty - Dewatering Duty Submersible Pumps	59
Special Duty - USDA Certified Pumps	60-61
Special Duty - FDA Material Compliant Pumps	62-63
Special Duty - Mining / Construction Pumps	64-65
Special Duty - Natural Gas-Operated Pumps	66-68
CSA Certified Natural Gas Regulators	69
One-Piece Bonded Diaphragm	70
AODD Principle of Operation	71
Materials Profile / Recommended Installation	72
Commitment to Quality Products	73
Warranty and Performance Guarantees	74
Genuine Parts Kits	75

SOLUTION PROVIDING ADVANTAGES...

Informed customers select AODD pumps vs. other pump types when challenged with difficult pumping situations including:

- Suspended Solids
- Non-Suspended Solids
- Line-Size Solids
- Abrasive Sludge & Slurries
- High Viscosity Fluids
- Dry Running
- Slip
- High Suction Lift
- Corrosive Fluids
- Heat Generation
- Loss of Suction (Prime Damage)
- Floor Space Restrictions
- Deadheading
- Shaft Deflections
- Coupling Misalignment
- Added Costs for Variable Flow Rates
- Added Costs for Installation Bypass Lines
- Added Costs for Pressure Relief
- High Costs Associated with Packing Glands & Mechanical Seals
- Bearing/Shaft (Load) Problems Associated with Operating Below Minimum Flow
- Catastrophic Mechanical Seal Failures
- Leakage from Packed Stuffing Boxes
- Insufficient NPSH (a) Cavitation
- Bearing Lubrication Contamination
- Decreased Volumetric Efficiency

Classification of Pump Types:

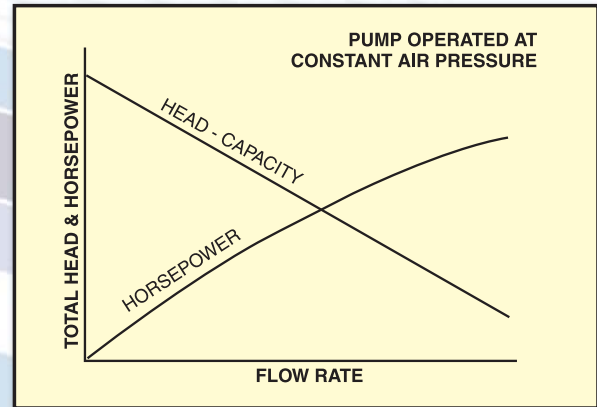
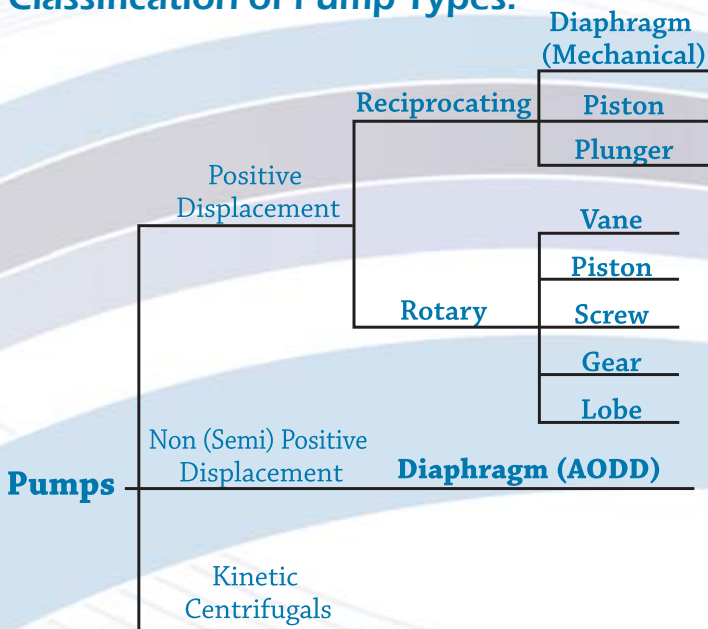

Although the AODD pump is a displacement type, it is actually a hybrid and defies strict classification. While its pressure versus capacity characteristics resemble those of a centrifugal pump, it is best defined as a sealless, non (or semi) positive displacement pump. The pumping principle provides 100% efficiency at zero flow.

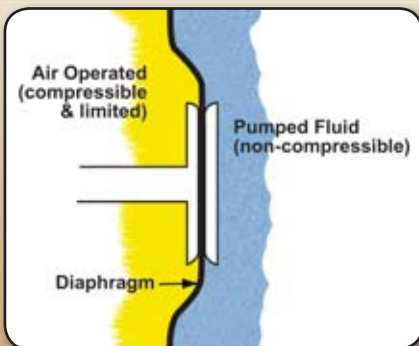

AODD pumps are air (or natural gas) operated displacement type pumps which uniquely differ from all other positive displacement pumps. As a result of air pressure acting on the entire surface of the diaphragm, the diaphragm is in a balanced condition while pumping. This measurably extends diaphragm life over that of mechanically operated diaphragm pumps. Because compressed air is limited, the maximum pressure developed by the pump is also safely limited. Thus, AODD pumps are appropriately selected for on-demand intermittent requirements.

AIR-OPERATED DOUBLE DIAPHRAGM PUMPS

Variable flow and head conditions are achievable with the use of inexpensive off-the-shelf air line pressure regulators. Other commonly used flow control methods include restricting discharge and/or suction shutoff valves. Today, AODD pumps are appropriately selected for "process control" installations as automated control devices have become commercially available.

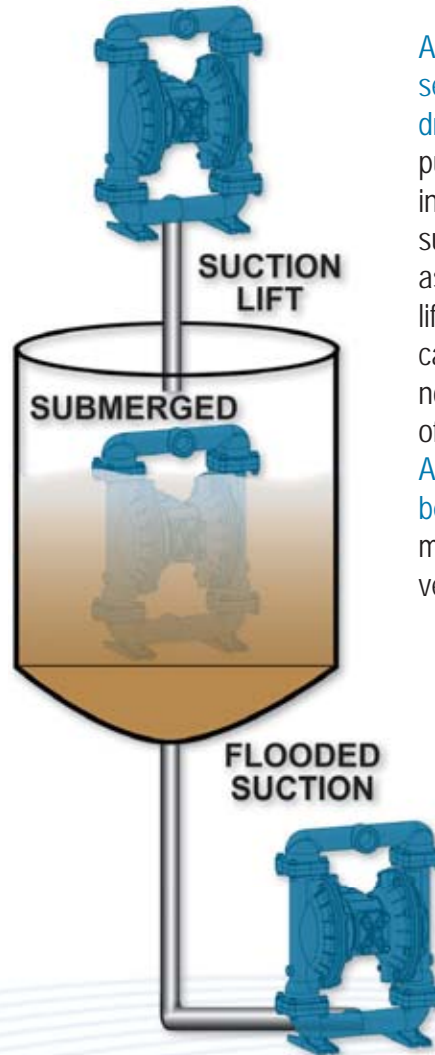
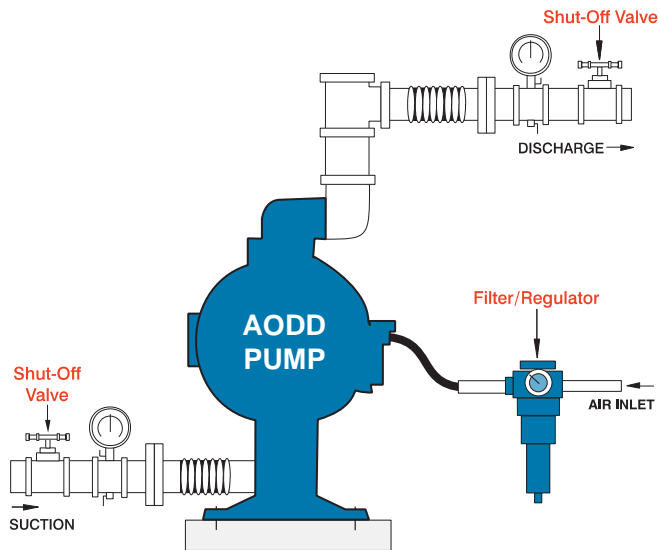

AODD pumps are self-priming from a dry start, but these pumps are frequently installed in flooded suction installations as well as on suction lift installations. With caution given to the non-wetted materials of construction, AODD pumps can be submerged for maximum installation versatility.

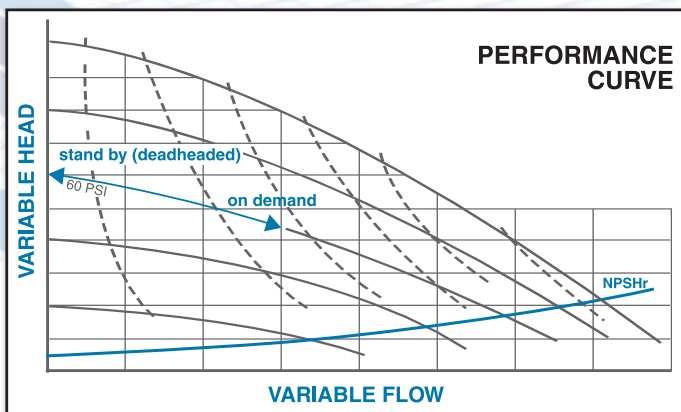

Air-operated double diaphragm pumps safely operate on deadheaded/standby demand without added costs associated with the need to relieve pressure. More importantly, at all deadheaded condition points, the AODD pump consumes zero energy (SCFM).



Solution providing AODD pump installation selected to reduce total costs of ownership and minimize floor space allocation.

SOLUTION PROVIDING CAPABILITIES

- **Pumps abrasive and shear-sensitive materials**
Low internal velocities handle abrasive slurries with no damage to the pump or loss of volumetric efficiencies. The gentle pumping action does not shear fragile materials.
- **Pumps high viscosity fluids**
Heavy and pourable fluids efficiently handled
- **Pumps solids up to 3" line size**
- **Sealless**
No mechanical seals or packing to leak
- **Self-priming**
Maximum dry prime capabilities up to 24 ft. of water
- **Variable flow & pressure**
Simply regulate the inlet air supply to adjust the pump flow from zero to maximum rated capacity.
- **Optional discharge porting**
Select bottom porting for high concentration of heavy solids. Select top porting for thin liquids, or if entrained air could be a problem.
- **Runs dry without damage or heat build-up**
No internal damage
- **Deadheads against closed discharge**
Discharge pressures equal to or greater than inlet air pressure stops the pump without damage. Expensive bypass systems & pressure relief valves not required. The pump stops operation until the discharge is opened.
- **Fully groundable**
- **Portable & submersible**
- **Certifications**



ATEX



CSA



UL



CE



USDA



FDA



ABS

**Please refer to the model specific Service Manual and Data Sheet for complete ATEX information.*

PRIMARY MARKETS



Automotive / Plating & Finishing



Oil & Gas



Paint / Ink / Coatings



Chemical / Petrochemical



Mining



Industrial / Municipal Wastewater Treatment



Food Processing / Biotech / Pharmaceutical



Ceramic Slip / Glaze



Pulp / Paper Converters



Construction / Utilities

Primary Market Process Maps

Ideal Pump Types for your Ceramic Process

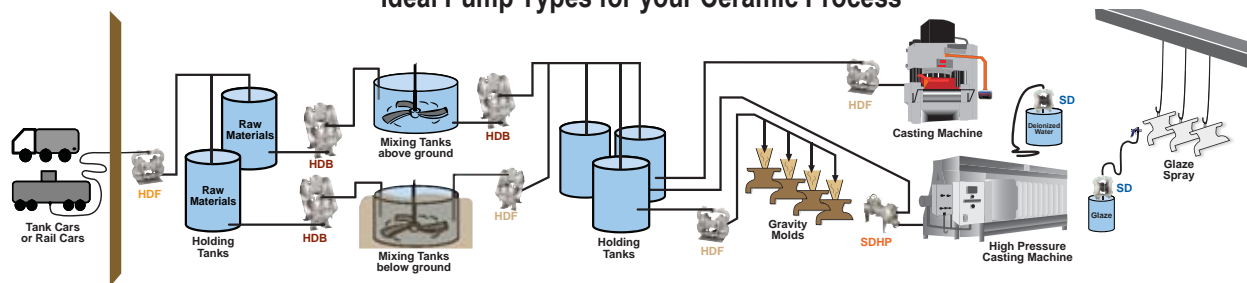

Ideal Pump Types for your Natural Gas Process

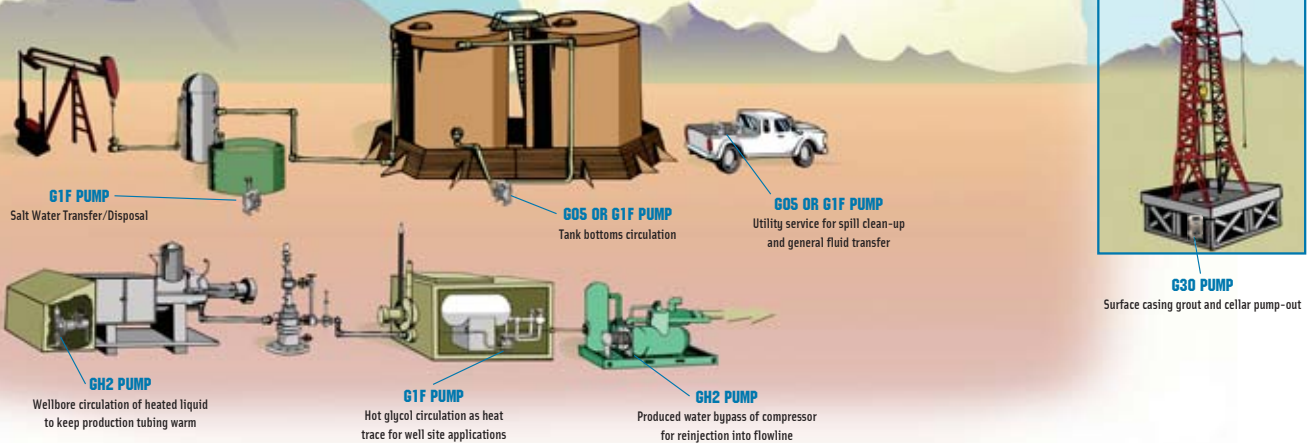

Ideal Pump Types for your Paint Process

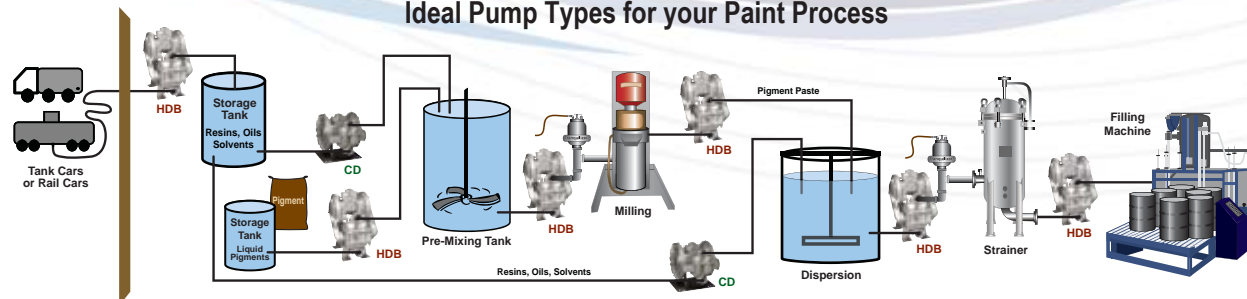

SIGNATURE DESIGN PLATFORM

ESADS+Plus® (Externally Serviceable Air Distribution System)

ON-OFF-ON... Reliability - GUARANTEED!

Primary system components = main directional air valve
(with PATENTED cross-drilled pressure ports) & pilot valve

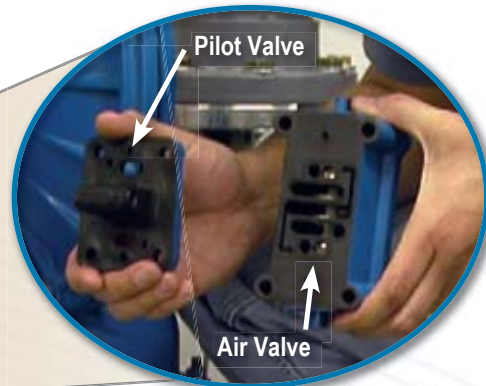

Completely Serviceable, "IN-LINE"

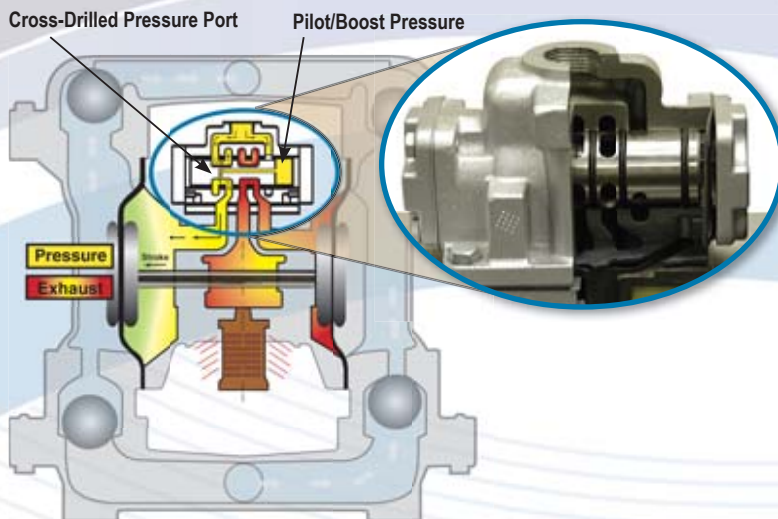

■ **FEATURES:** Independent of the pilot valve position, the cross-drilled pressure ports in the main directional air valve spool provide a pneumatic bias of the spool at either end of travel. This is accomplished by directing (inner) chamber pressure to the end of the spool, boosting and sustaining pilot pressure until point-of-shift of the pilot valve.

■ **BENEFITS:** Eliminates spool from drifting due to vibration and/or unbalanced pressure or system conditions.

- Process Reliability
- Consistent restarts
- Complete IN-LINE serviceability
- Lube Free

Connecting Rod Guarantee

GUARANTEED not to yield under:

- Tension
- Compression
- Bending
- Pump Operation

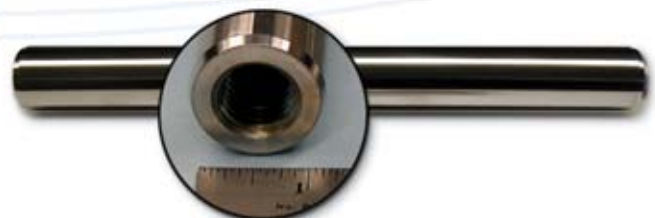

Durable, corrosion resistant 416 (Martensitic) and/or 316 (Austenitic)
Stainless Steel diaphragm connecting rod - **GUARANTEED!**

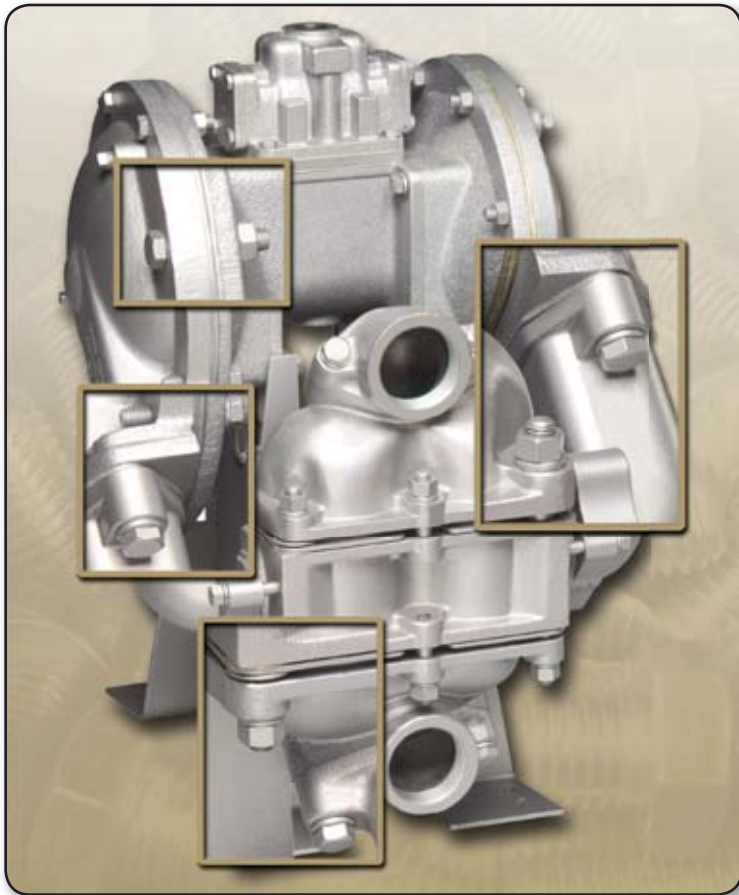

All Bolted Construction

- Instant alignment
 - Ease of maintenance
- Uniform torquing of seal
 - Improved seal
- Maintains seal after repeated servicing
 - Lowers repair costs
- Withstands 4 times the pressure versus V-band clamps
 - Eliminates leakage at high pressure and deadheaded conditions

EXCLUSIVE Bottom Discharge Porting

SANDPIPER® designs

Heavy Duty Flap

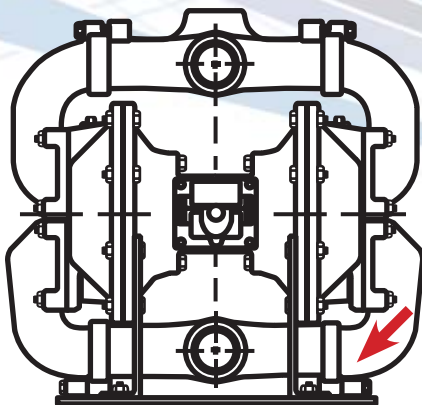

Heavy Duty Ball

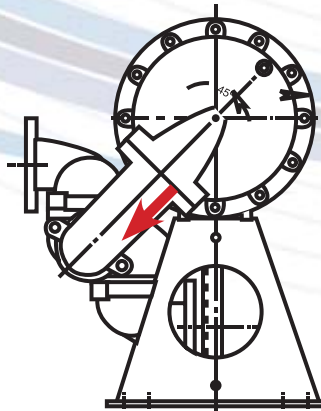

Standard Duty

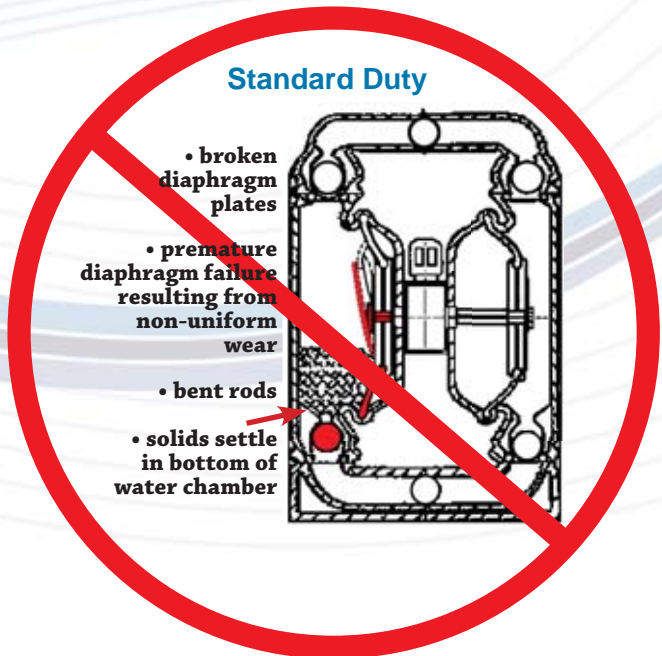

- broken diaphragm plates
- premature diaphragm failure resulting from non-uniform wear
- bent rods
- solids settle in bottom of water chamber

SIGNATURE CONFIGURATIONS

Heavy Duty Ball

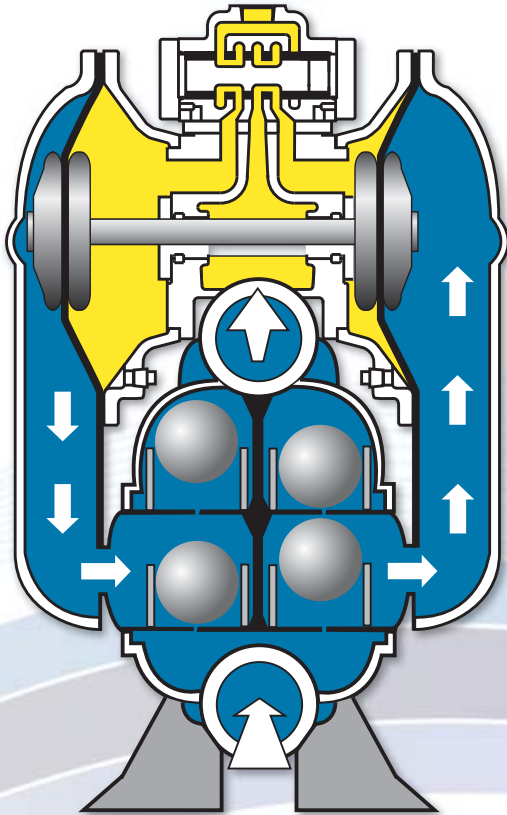

Heavy Duty Flap

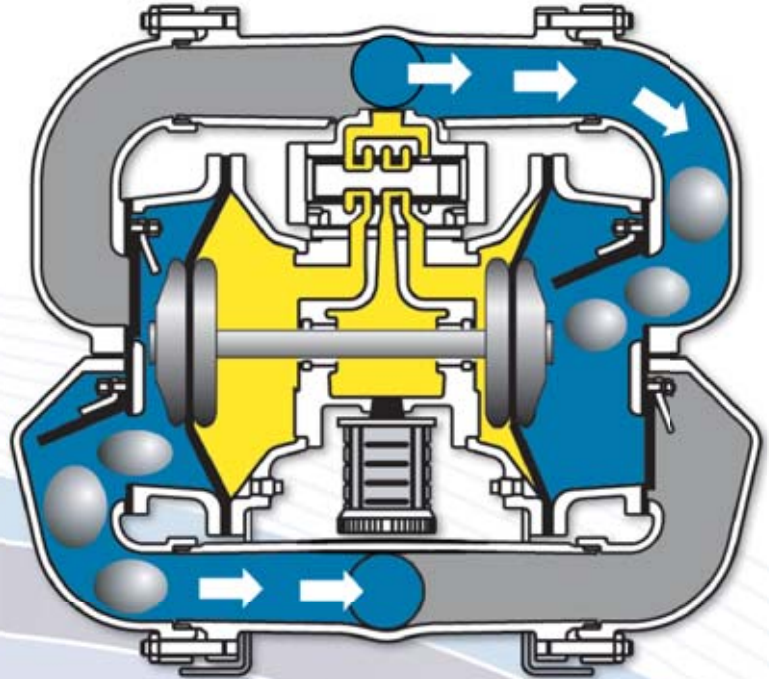

HIGH EFFICIENCY

HEAVY DUTY BALL

HEAVY DUTY FLAP

CONTAINMENT DUTY

STANDARD DUTY

FEATURES - BENEFITS

ESADS+Plus® • Performance Guaranteed • In-line Serviceable Air Valve System

Bolted Construction • Safe • Reliable • Easy Maintenance

Durable • Single-Purpose • Corrosion Resistant • Guaranteed Diaphragm Connecting Rod

Bottom Discharge Porting - Eliminates Settling Solids

Thick Wall Construction

Horizontal and Vertical Manifold Connections

Free Standing Base - Reduces Downtime - Easy Re-Build

Heavy Duty Wear Package - Extends "MTBF"

Weighted Ball Check Valves

Solids Range
+1/4" (6mm) to 7/8" (22mm)

Dry Primes up to 20 Feet of Water

Hinged Flap Check Valves

Solids Range
+1" (25mm) to 3" (76mm)

Dry Primes up to 24 Feet of Water

Containment Duty Metallic & Non-Metallic

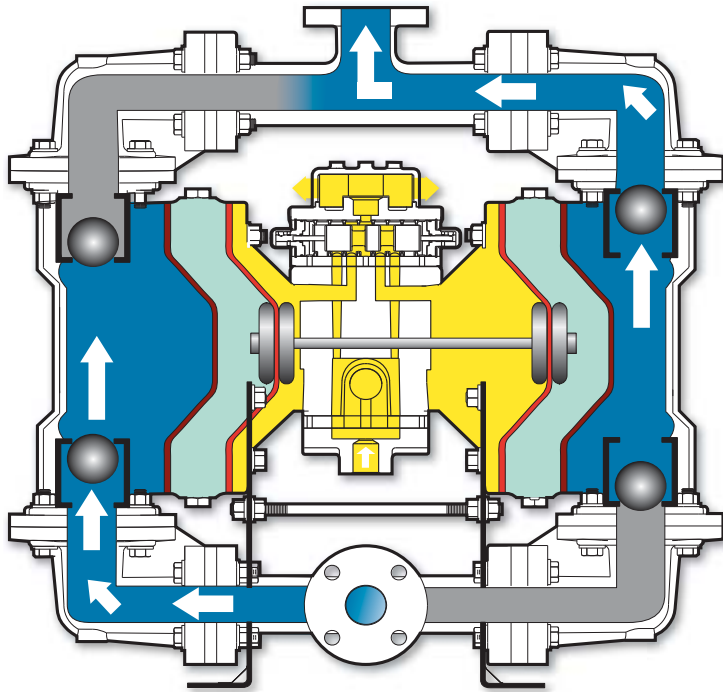

Standard Duty Metallic & Non-Metallic

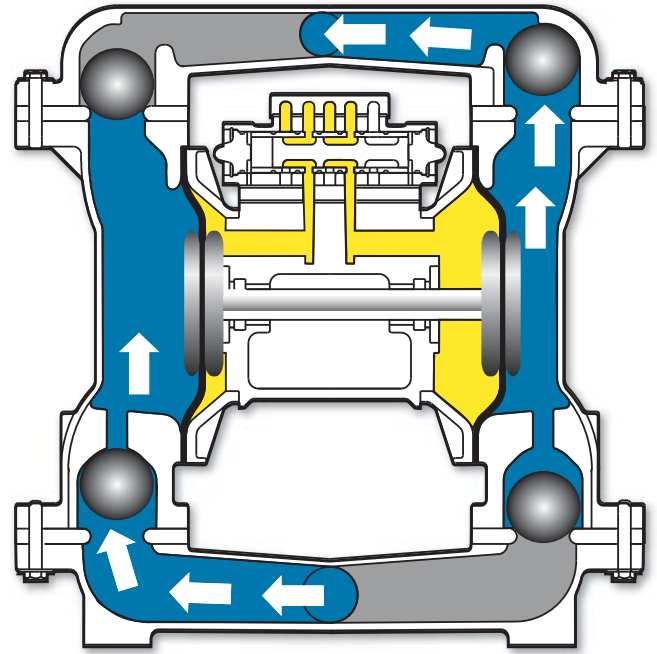

- HIGH EFFICIENCY
- HEAVY DUTY BALL
- HEAVY DUTY FLAP
- CONTAINMENT DUTY
- STANDARD DUTY

FEATURES - BENEFITS

ESADS+Plus® - Performance Guaranteed - In-line Serviceable Air Valve System

Bolted Construction • Safe • Reliable • Easy Maintenance

Durable • Single-Purpose • Corrosion Resistant • Guaranteed Diaphragm Connecting Rod

Top Discharge Porting - Eliminates Entrained Air

Metallic and Non-Metallic Materials of Construction

Ball Check Valves - Light Weight - Portable

90° - 180° Manifold Connection Rotation

Containment Chamber with Leak Detection

Hydraulically Balanced/Coupled Pumping
and Driver Diaphragm Assemblies

Solids Range +1/4" (6mm) to 3/4" (18mm)

Dry Primes up to 18 Feet of Water

Free Standing Support Base

Solids Range +1/8" (3mm) to 1/2" (12.7mm)

Dry Primes up to 20 Feet of Water

BEST PRACTICES - PUMP SELECTION

A. SELECT PUMP DESIGN

A fundamental review of fluid characteristics, intended installation, and duty requirements are recommended for “best fit” design selections.

This design selection best practice ensures longest life, whether measuring:

- **MTBF:** Mean Time Between Failures,
- **MTBR:** Mean Time Between Repairs,
- **MTBC:** Mean Time Between Changes or
- **MTBM:** Mean Time Between Maintenance

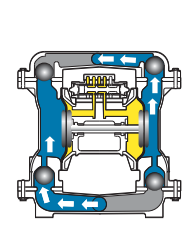
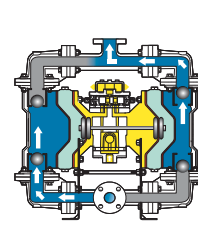
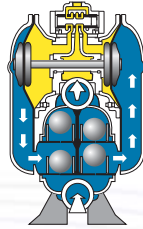

CHARACTERISTICS CHART:

		Heavy Duty Ball Bottom Discharge	Heavy Duty Flap Bottom Discharge	Containment Duty Top Discharge		Standard Duty Top Discharge		
				Metallic	Non-Metallic	Metallic	Non-Metallic	
Fluid Characteristics	Water (Base Reference)	A	A	A	A	A	A	
	Suspended Solids	A (top discharge porting)	B	A	B	A	B	
	Non-Suspended Solids	A (bottom discharge porting)	A (bottom discharge porting)	X	X	C	X	
	Line Size Solids	X	A	X	X	X	X	
	Sludge / Slurry	A (bottom discharge porting)	A (bottom discharge porting)	B	C	B	C	
	High Viscosity (Flowable Fluids)	A (weighted check valves)	B	B	B	B	B	
	Erosion / Abrasive Fluids	High	A	A	B	C	B	C
		Moderate	A	A	B	C	B	C
Low		A	A	A	B	A	B	
Corrosion	B	B	B	A	B	A		

Installation	Permanent	A	A	B	B	B	B
	Portable	B	A	A	A	A	A
	Containment / Prevention	C	C	A	A	C	C
	Flooded Suction	A (weighted check valves)	B	B	B	B	B
	Suction Lift	B	A	B	B	B	B
	Submerged	B	B	B	C	B	C

Duty	Intermittent / On-Demand	A	A	A	A	A	A
	Continuous	A	B	B	B	B	B

A = Best Type	B = Suitable	C = Caution (Limitations)	X = Unsuitable
---------------	--------------	---------------------------	----------------

B. SELECT MATERIALS OF CONSTRUCTION

Reference the SANDPIPER® Chemical Resistance Chart

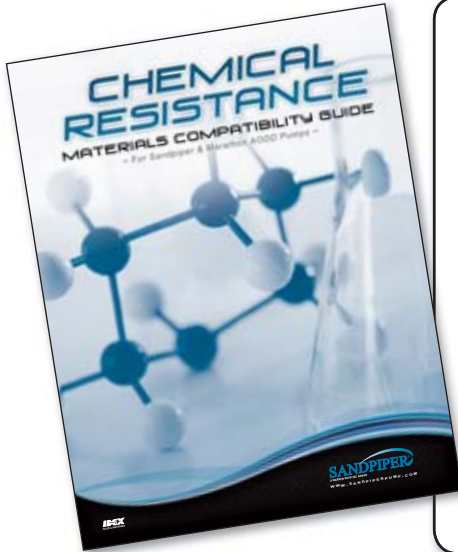

CHEMICAL Formula	ELASTOMERS							METAL PARTS			PLASTICS									
	RUPPOL® (Polyurethane)	NEOPRENE	BUNA-N	EPDM	NITREL®	(FPM) FLUOROCARBON	BLUE GYLOX®	PTEE, PFA	ENVELOX®	SANDPIPER®	ALUMINUM	CAST IRON/STEEL	STAINLESS STEEL	Alloy C (Monelloy & Incoloy)	POLYPROPYLENE	ACETAL	PI/PF	NYLON	RYTON®	UNSKN POLYETHYLENE
Lime, Soda (Sieved Lime & Soda Ash) CaO	C	B	B	A		B	A	A												
Lime Bleach	C	A	A	A		A	A	A	X					B						
Lime Slurries	A	B		C	B	A	A			B		B								
Lime Sulfur CaS+CaSO ₄		A	A	A		A	A		B	X		A		A				B		A
Limonene C ₁₀ H ₁₆		X	C	X		A	A													
Linoleic Acid C ₁₈ H ₃₂ O ₂		X	B	X		B	A		B	A		A	A	A						
Linseed Oil (Flaxseed Oil) Glycerides		B	A	A	C	B	A	A	A	B		A	A	A						
Lindol (Triethyl Phosphate) C ₁₂ H ₂₆ O ₃ P		C	X			B	A		A											
Lithium Bromide LiBrH ₂ O		X	A			A	A	A				A								A
Lubricating Oils (Petroleum) Hydrocarbons	C	B	A	X	A	A	A	A	A	X		A	A	A	A	C	A	A	A	A
Lye (Potassium Hydroxide)																				

C. SELECT PUMP SIZE

1) Enter Flow (GPM) and Head
(example: 60 GPM @ 40 PSI)

2) Approximate energy requirements
in Pressure and Volume
(example: 62 PSI @ 50 SCFM)

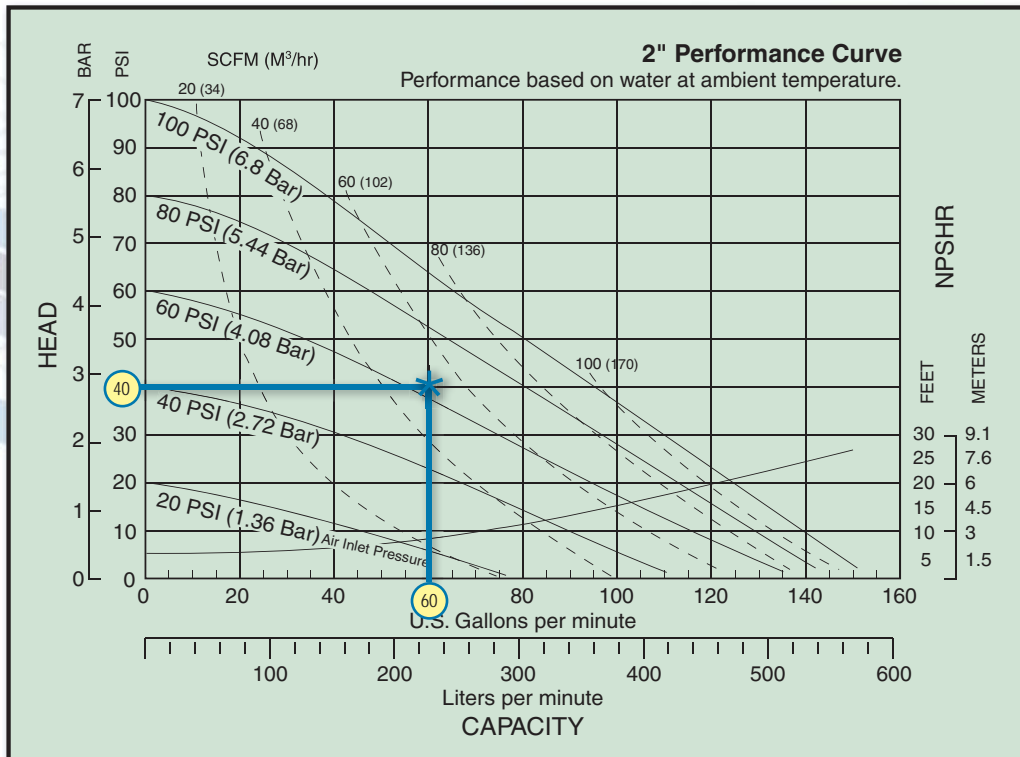

Sizing to extend MTBF (Mean Time Between Failures)

Pumping requirements (flow & head) for most applications can be met by multiple sizes of pumps. Talk to SANDPIPER'S application engineers to assist you with a size selection which best fits your total cost of ownership budget. An appropriately sized-up pump will lower the consolidated initial investment, repair, labor and energy costs. This BEST PRACTICE ensures desirable returns on the initial investment frequently measurable in weeks.

EXAMPLE: 80 GPM @ 30 PSI



Experienced application engineers are available to help you determine the best fit pump size for your application. Call our factory or email apptech.warrenrupp@idexcorp.com.

1 1/2" Performance Curve. 30 PSI, 80 GPM = 90 SCFM

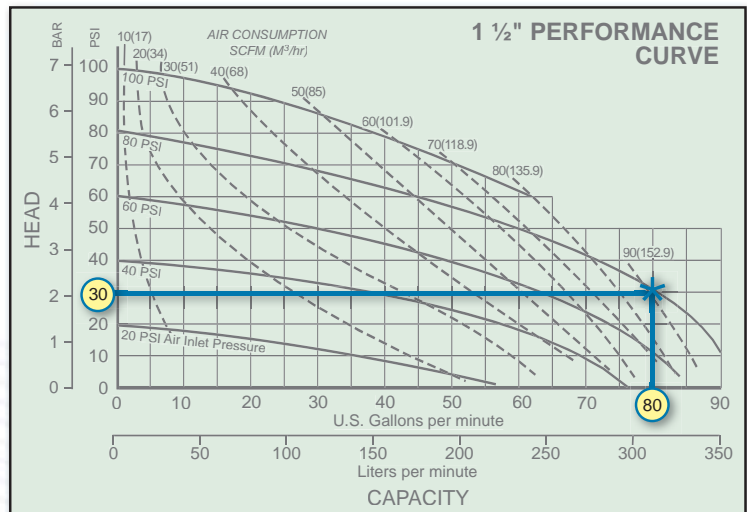

2" Performance Curve. 30 PSI, 80 GPM = 55 SCFM

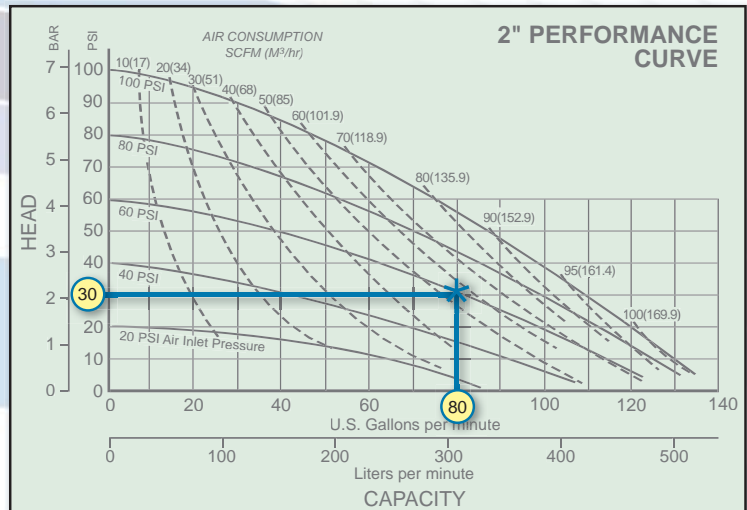

3" Performance Curve. 30 PSI, 80 GPM = 45 SCFM

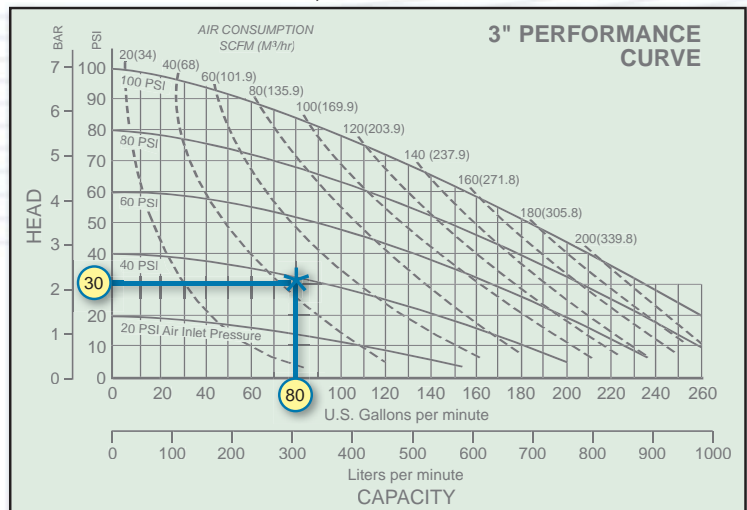

LOWER TOTAL COST OF OWNERSHIP

Comparative Example

Compare the total cost of ownership of 2 to 3 AODD pump sizes, including purchase price, compressed air cost, repair parts cost, and maintenance labor cost. Required inputs are flow rate (GPM), discharge pressure (PSI), air inlet pressure (PSI), air consumption (SCFM), displacement per stroke (gal), wet end kit cost, electricity cost (\$/kw-hr), labor cost (\$/hr) and weekly hours of operation.

INDUSTRY ACCEPTED BEST PRACTICES & ASSUMPTIONS

- Maintenance performed every 10 million pump strokes
- Two hours of labor required for each rebuild

Step 1: Input Pump Data

Pump Size	Model	Price (\$)	Flow Rate (GPM)	Discharge Pressure (PSI)	Air Inlet Pressure (PSI)	Air Consumption (SCFM)	Displacement per Stroke (gal)	Wet End Kit Cost (\$)
A	1½"	\$1,217.00			79	91	0.34	\$151.42
B	2"	\$1,354.00	80	30	60	55	0.43	\$249.85
C	3"	\$3,225.00			37	43	1.8	\$508.35

Step 2: Input Cost Data

Electricity Cost (\$/kw-hr)	\$ 0.07
Labor Cost (\$/hr)	\$75.00
Weekly Hours of Operation	40

Step 3: View Cost Summary

Pump Size	Annual Air Consumption Cost	Annual Replacement Parts Cost	Annual Maintenance Labor Cost	Maintenance Frequency (weeks)	Weekly Pump Operating Cost	Annual Pump Operating Cost	Total First Year Investment (Price + Operating Cost)
A	\$1,720.18	\$221.70	\$220.24	35	\$41.58	\$2,162.12	\$3,379.12
B	\$ 880.89	\$290.23	\$174.14	45	\$25.87	\$1,345.26	\$2,699.26
C	\$ 514.70	\$140.89	\$ 41.60	188	\$13.41	\$ 697.18	\$3,922.18

Step 4: Evaluate Return on Investment

Additional Investment Payback Period (weeks)

Pump Size B (Higher Price) vs. Pump Size A (Lower Price)
= 8.7 weeks

Total Cost of Ownership calculator allows user to compare the total cost of ownership of 2 to 3 AODD pump sizes. This calculator is available through IDEX Commercial Operations Regional Managers.

HIGH EFFICIENCY - AIRVANTAGE®



SAVE Energy • SAVE Compressor Cost • SAVE Operator Cost



HIGH EFFICIENCY

Go Green, Save Green

AirVantage is a new technology for Air Operated Double Diaphragm pumps that significantly reduces air consumption over conventional AODD pumps.

- Advanced learning program modulates pump performance to optimize energy usage and match changes in system demand.
- Automatically adapts to changing process conditions by constantly managing the amount of air that is used to drive the pump.
- Completely sustainable with a self-contained 12v power generation module, only needs compressed air. No need for batteries or hard-wiring.

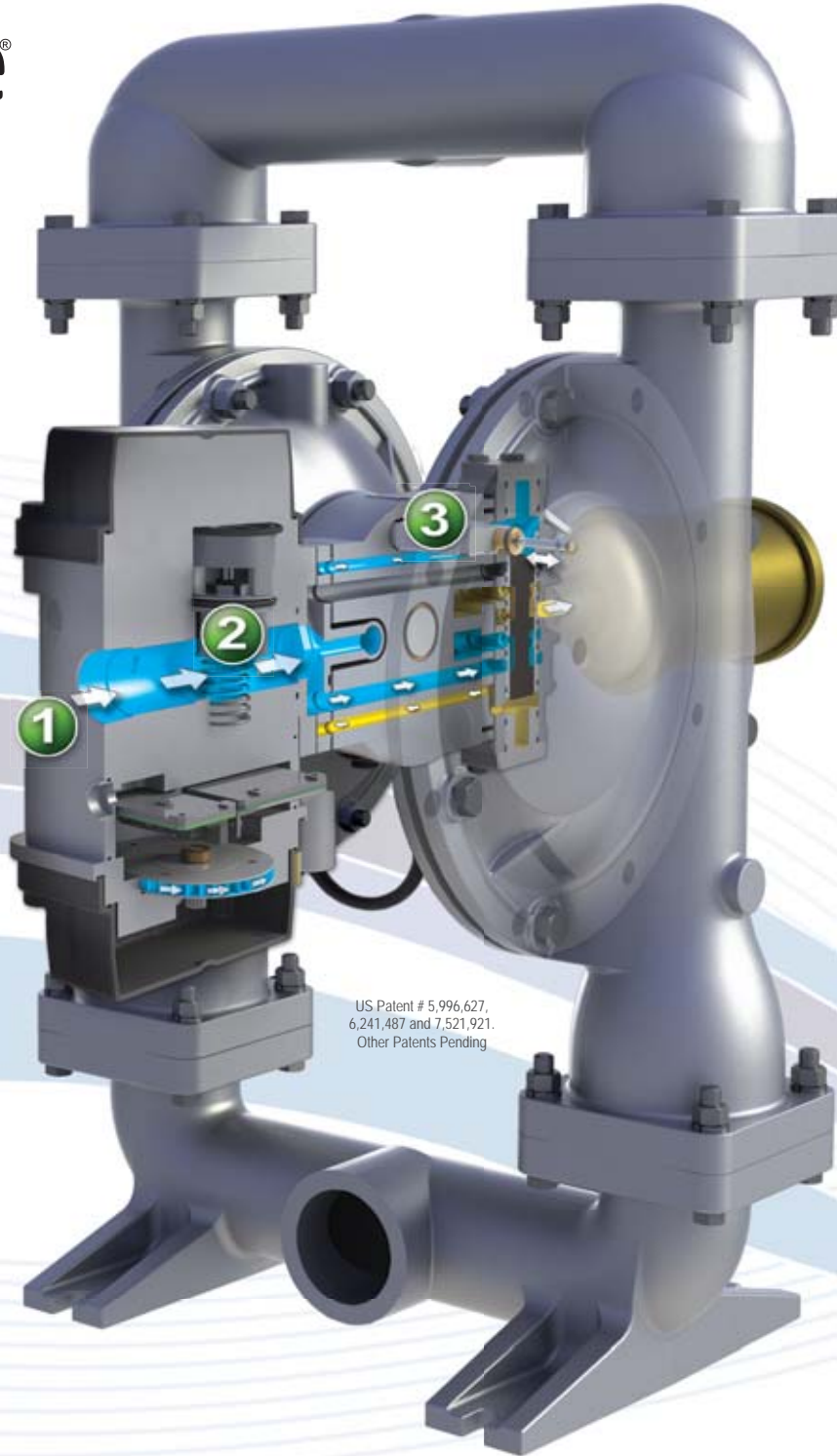

US Patent # 5,996,627,
6,241,487 and 7,521,921.
Other Patents Pending

 Hazardous Certified Options 

Step 1

- Air enters main inlet.
- Small amount of air directed to turbine that powers the unit.

Step 2

- Air regulator valve controls air flow volume.
- Air continues on standard path through air system.

Step 3

- Sensor monitors pump velocity, sends data to microprocessor.
- Microprocessor calculates ideal air usage, regulates air valve.

FEATURES/BENEFITS: SAME FEATURES AS STANDARD & HEAVY DUTY

- Saves up to 50% air consumption
- Relieves air compressor demand
- Reduces equipment maintenance & repairs
- “Dial-Free” operation self adjusts to process changes
- Reduces factory noise levels
- No electricity or battery back-up required



Heavy Duty
Ball



Standard
Duty



Heavy Duty
Flap

CURVES :

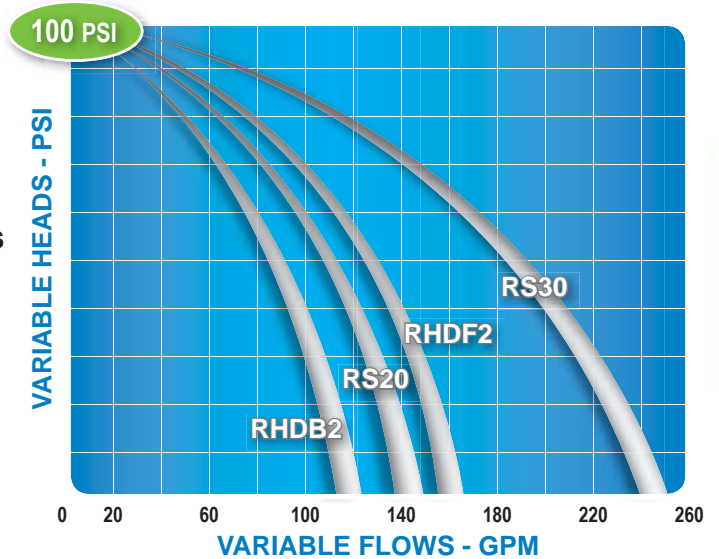

HIGH EFFICIENCY

AirVantage RS30 vs. Competition Annual Savings

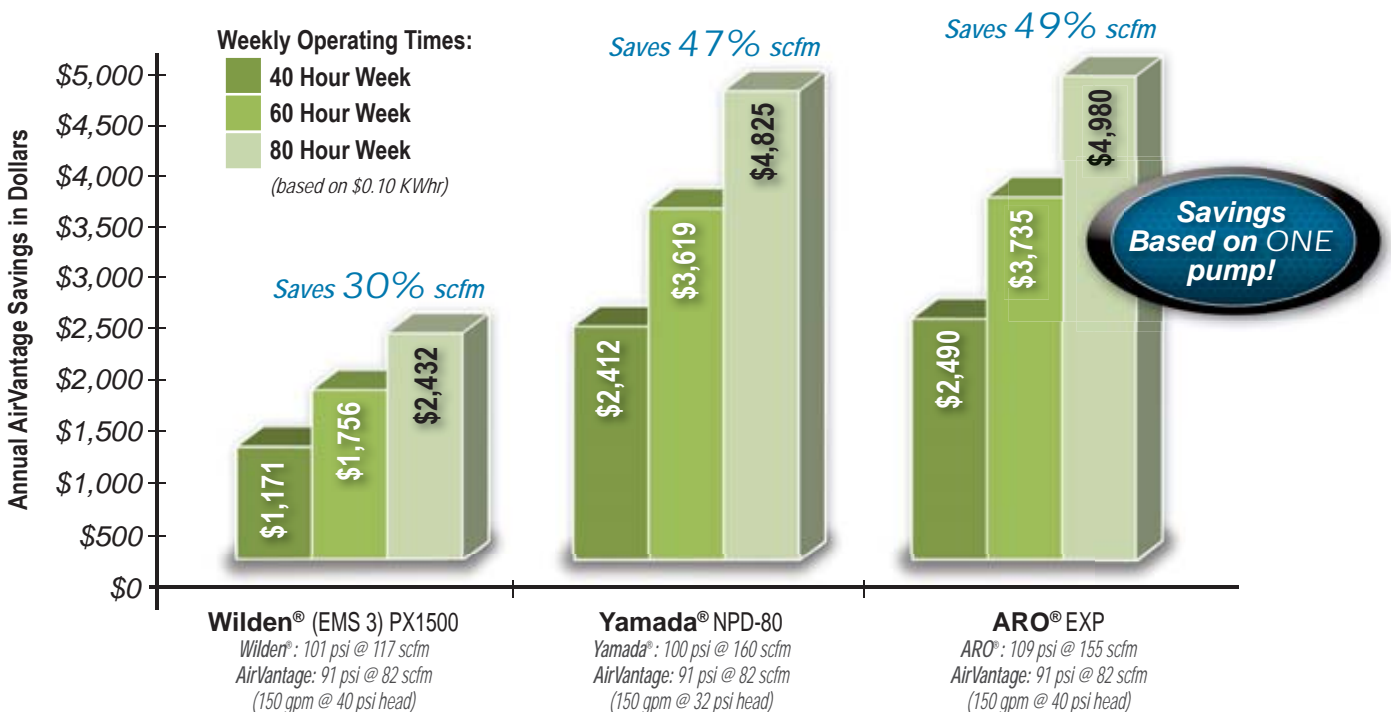

*Comparisons made from published data

Wilden® is a registered tradename of Wilden Pump & Engineering Company a Dover Resources Company
 ARO® is a registered tradename of Ingersoll-Rand Company • Yamada® is a registered tradename of Yamada Corporation

HEAVY DUTY BALL

All Bolted Construction

ESADS+Plus®
(Externally Serviceable
Air Distribution System)
Lube Free

Durable
Diaphragm
Connecting Rod

Thick Wall
Construction

Weighted
Elastomeric
Ball Checks

Bottom
Discharge
Ported

Rotate Porting
Flange 180°
to Achieve 90°
Vertical
Connections

Free Standing
Support Base

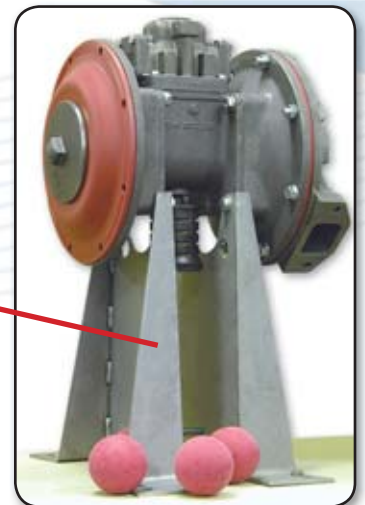

HEAVY DUTY BALL

SANDPIPER Signature Features - in BLUE

CONFIGURATION FEATURES

FEATURES:

- HEAVY DUTY BALL
- ESADS+Plus®
- All Bolted Construction
- Bottom Discharge
- Thick Wall Construction
- Durable Diaphragm Connecting Rod
- Horizontal & Vertical Manifold Connections
- Solids Range +1/4" (6mm) to 7/8" (22mm)
- Dry Primes up to 20 Feet of Water
- Free Standing Support Base
- HD Extended Wear Package (1 1/2" to 4")

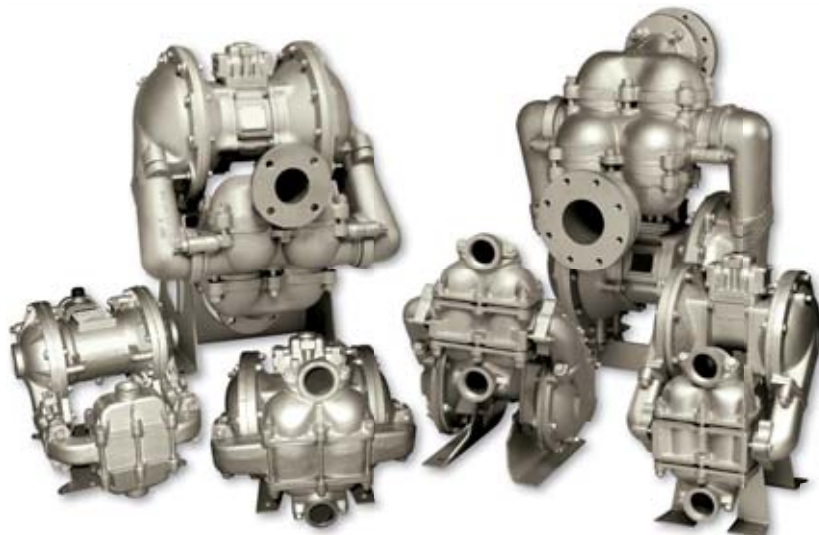

HEAVY DUTY BALL

CHARACTERISTICS CHART:

		Heavy Duty Ball Bottom Discharge
Fluid Characteristics	Water (base reference)	A
	Suspended Solids	A (top discharge porting)
	Non-Suspended Solids	A (bottom discharge porting)
	Line Size Solids	X
	Sludge / Slurry	A (bottom discharge porting)
	High Viscosity (Flowable Fluids)	A (weighted check valves)
	Erosion / Abrasive Fluids	High
Moderate		A
Low		A
Corrosion		B
Installation	Permanent	A
	Portable	B
	Containment / Prevention	C
	Flooded Suction	A (weighted check valves)
	Suction Lift	B
	Submerged	B
Duty	Intermittent / On-Demand	A
	Continuous	A
A = Best Type		C = Caution (Limitations)
B = Suitable		X = Unsuitable

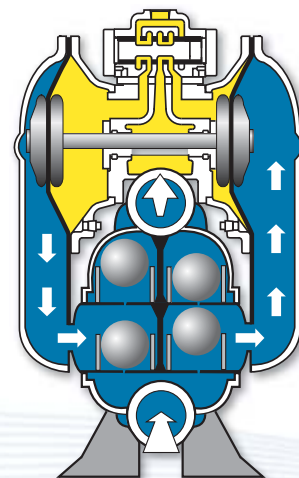

CURVES :

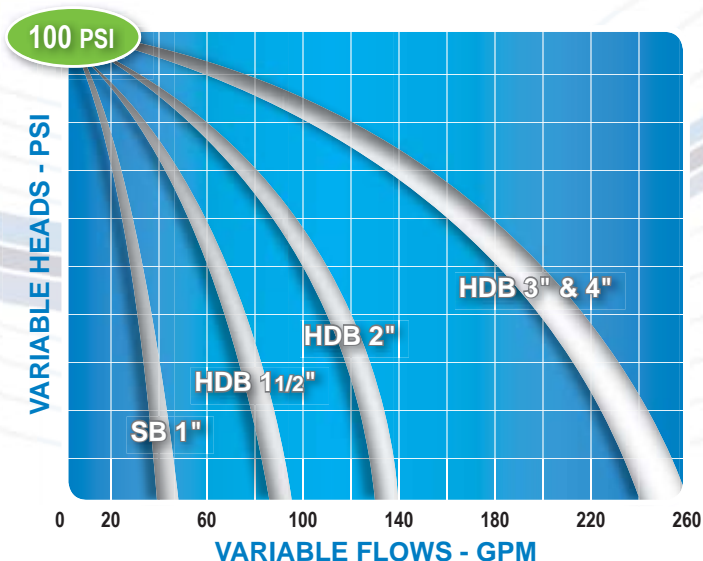

HEAVY DUTY FLAP

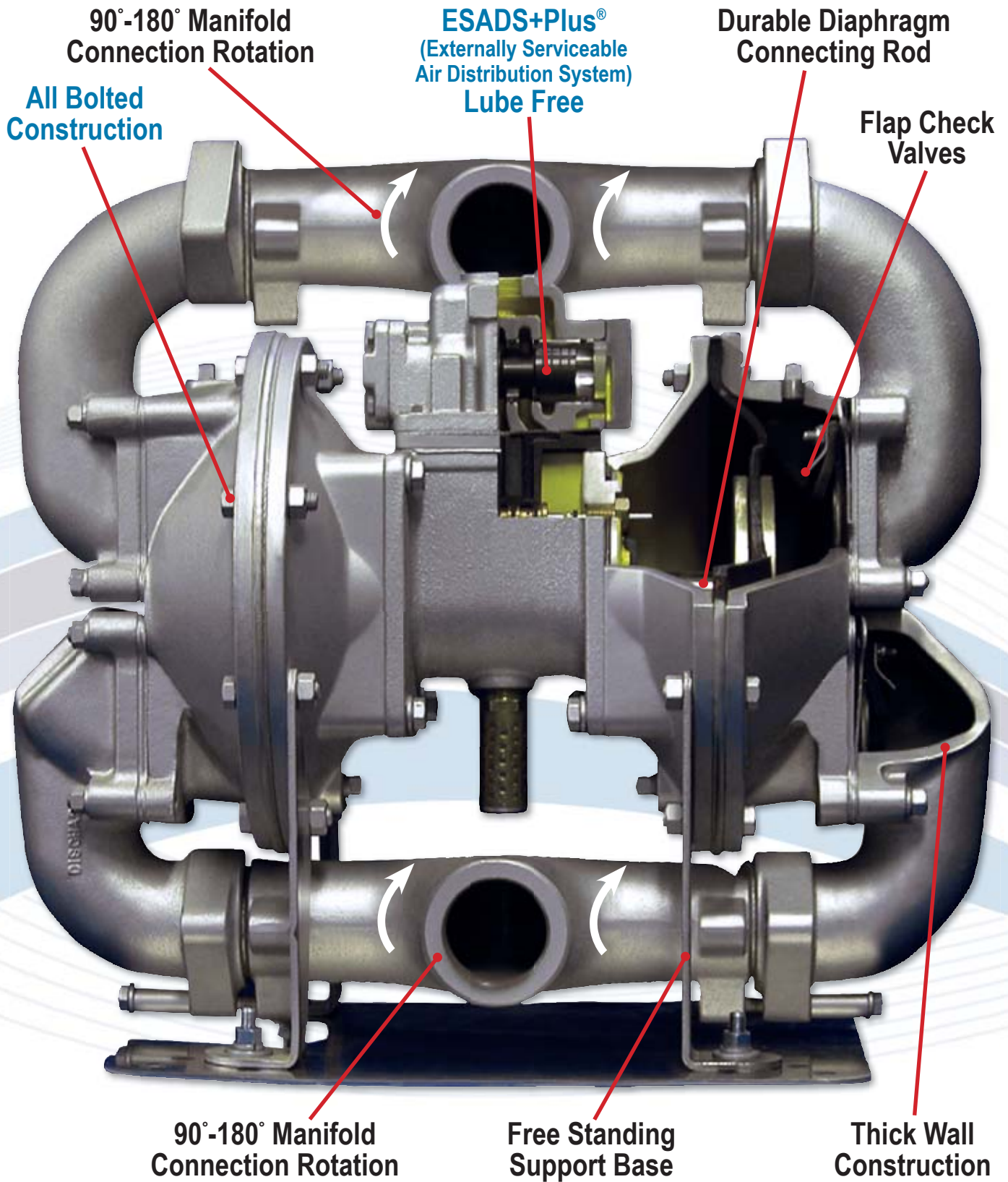

SANDPIPER Signature Features - in BLUE

CONFIGURATION FEATURES

FEATURES:

- HEAVY DUTY FLAP
- ESADS+Plus®
- All Bolted Construction
- Bottom Discharge
- Flap Check Valves
- Thick Wall Construction
- Durable Diaphragm Connecting Rod
- 90° - 180° Manifold Connection Rotation
- Solids Range +1" (25mm) to 3" (76mm)
- Dry Primes up to 24 Feet of Water
- Free Standing Support Base
- HD Extended Wear Package (2" to 4")

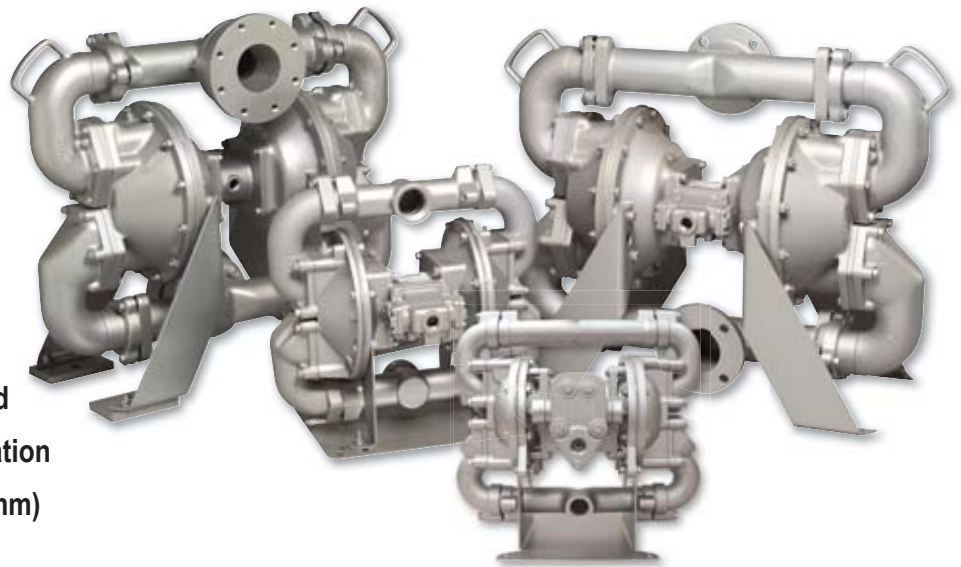

CHARACTERISTICS CHART:

		Heavy Duty Flap Bottom Discharge	
Fluid Characteristics	Water (base reference)	A	
	Suspended Solids	B	
	Non-Suspended Solids	A (bottom discharge porting)	
	Line Size Solids	A	
	Sludge / Slurry	A (bottom discharge porting)	
	High Viscosity (Flowable Fluids)	B	
	Erosion / Abrasive Fluids	High	A
		Moderate	A
Low		A	
Corrosion	B		
Installation	Permanent	A	
	Portable	A	
	Containment / Prevention	C	
	Flooded Suction	B	
	Suction Lift	A	
	Submerged	B	
Duty	Intermittent / On-Demand	A	
	Continuous	B	

A = Best Type C = Caution (Limitations)
 B = Suitable X = Unsuitable

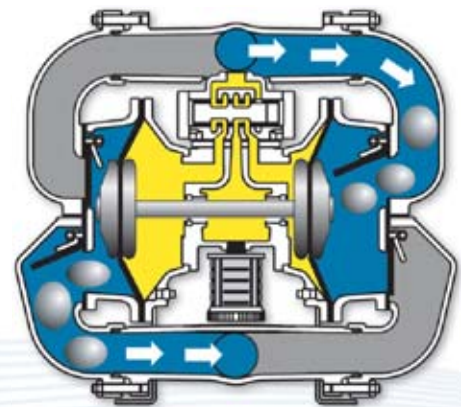

CURVES :

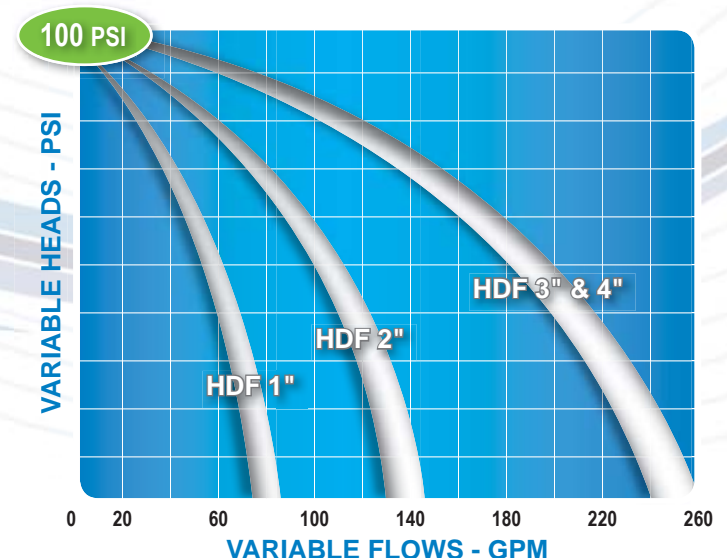

CONTAINMENT DUTY BALL

Hydraulically Balanced/
Coupled Pumping and
Driver Diaphragm
Assemblies

90°-180° Manifold
Connection Rotation

All Bolted
Construction

Containment
Chamber with Leak
Detection

ESADS+Plus®
(Externally Serviceable
Air Distribution System)
Lube Free

Durable Diaphragm
Connecting Rod

All Bolted
Construction

Free Standing
Support Base

SANDPIPER Signature Features - in BLUE

CONTAINMENT DUTY

CONFIGURATION FEATURES

FEATURES:

- CONTAINMENT DUTY BALL
- ESADS+Plus®
- All Bolted Construction
- Containment Chamber with Leak Detection
- Top Discharge
- Ball Check Valves
- Light Weight - Portable
- Durable Diaphragm Connecting Rod
- 90° - 180° Manifold Connection Rotation
- Solids Range +1/4" (6mm) to 3/4" (18mm)
- Dry Primes up to 18 Feet of Water
- Free Standing Support Base

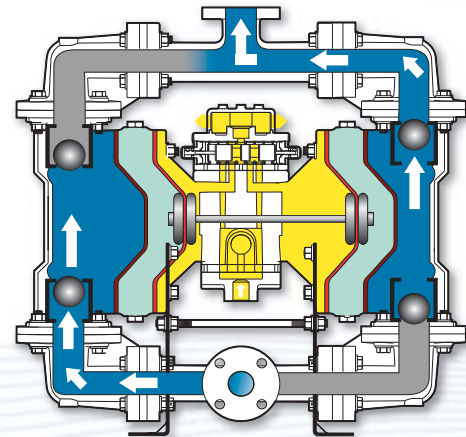

CHARACTERISTICS CHART:

		Containment Duty Top Discharge		
		Metallic	Non-Metallic	
Fluid Characteristics	Water (base reference)	A	A	
	Suspended Solids	A	B	
	Non-Suspended Solids	X	X	
	Line Size Solids	X	X	
	Sludge / Slurry	B	C	
	High Viscosity (Flowable Fluids)	B	B	
	Erosion / Abrasive Fluids	High	B	C
		Moderate	B	C
	Low	A	B	
	Corrosion	B	A	
Installation	Permanent	B	B	
	Portable	A	A	
	Containment / Prevention	A	A	
	Flooded Suction	B	B	
	Suction Lift	B	B	
	Submerged	B	C	
Duty	Intermittent / On-Demand	A	A	
	Continuous	B	B	

A = Best Type C = Caution (Limitations)
 B = Suitable X = Unsuitable

CURVES :

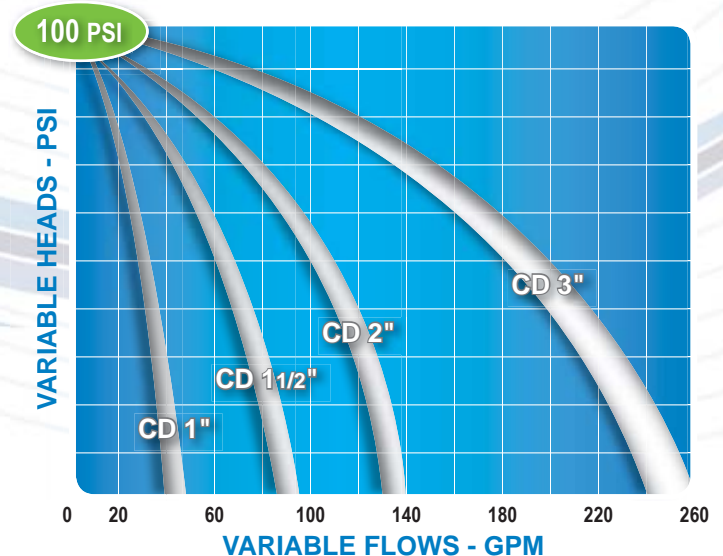

CONTAINMENT DUTY

STANDARD DUTY BALL

180° Manifold
Connection Rotation

All Bolted
Construction

ESADS+Plus®
(Externally Serviceable
Air Distribution System)
Lube Free

90°-180°
Manifold
Connection
Rotation

All Bolted
Construction

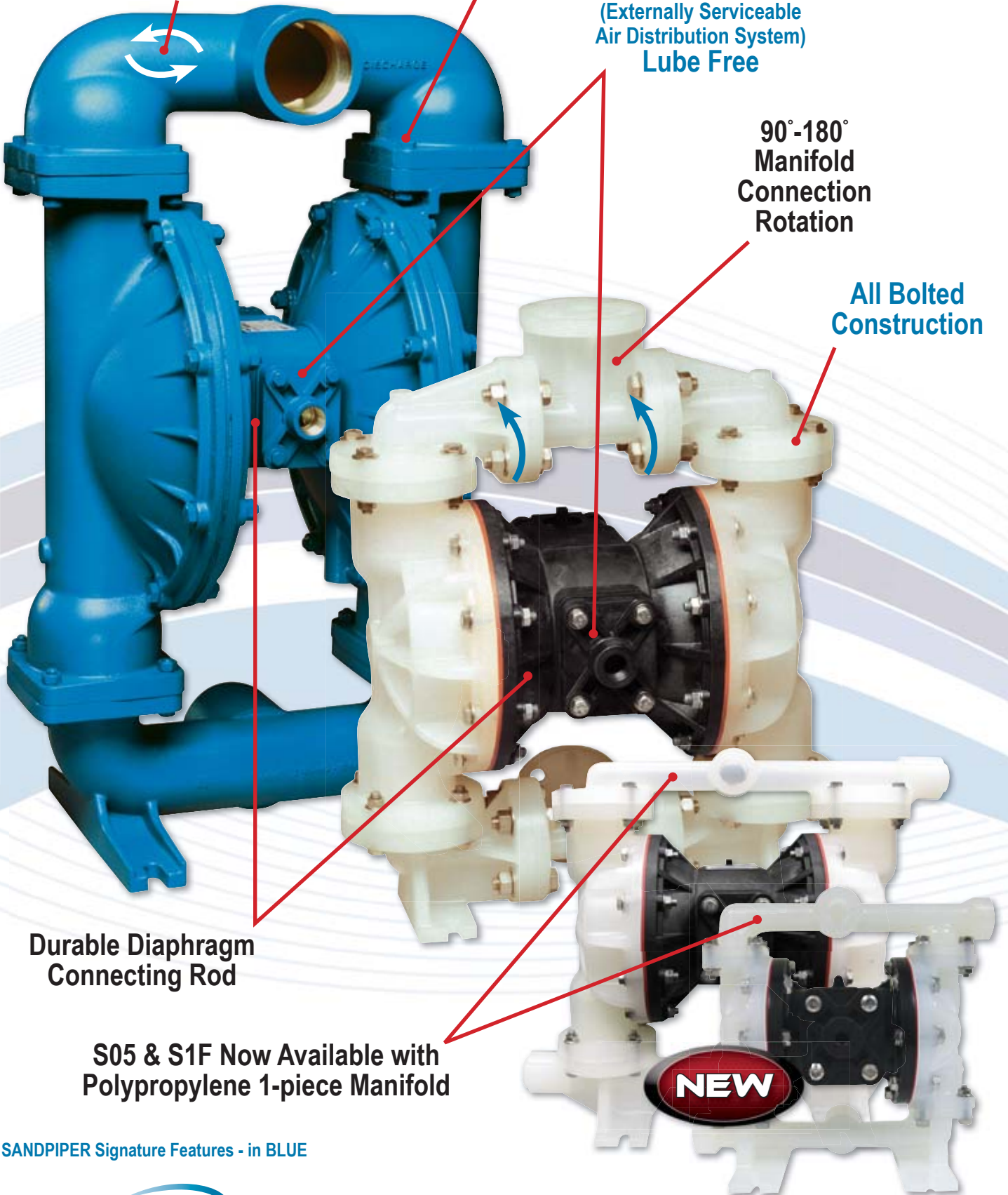

Durable Diaphragm
Connecting Rod

S05 & S1F Now Available with
Polypropylene 1-piece Manifold

NEW

STANDARD DUTY

SANDPIPER Signature Features - in BLUE

CONFIGURATION FEATURES

FEATURES:

- STANDARD DUTY BALL
- ESADS+Plus®
- All Bolted Construction
- Top Discharge
- Ball Check Valves
- Durable Diaphragm Connecting Rod
- Light Weight - Portable
- 90° - 180° Manifold Connection Rotation
- Solids Range +1/8" (2mm) to 1/2" (12.7mm)
- Dry Primes up to 20 Feet of Water

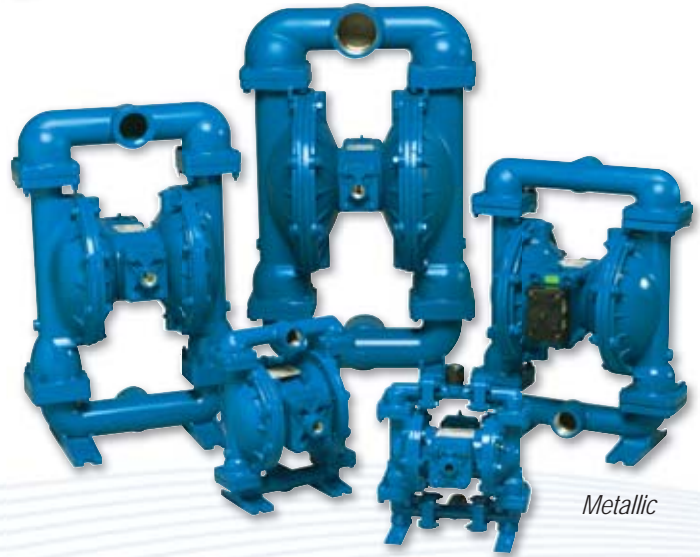
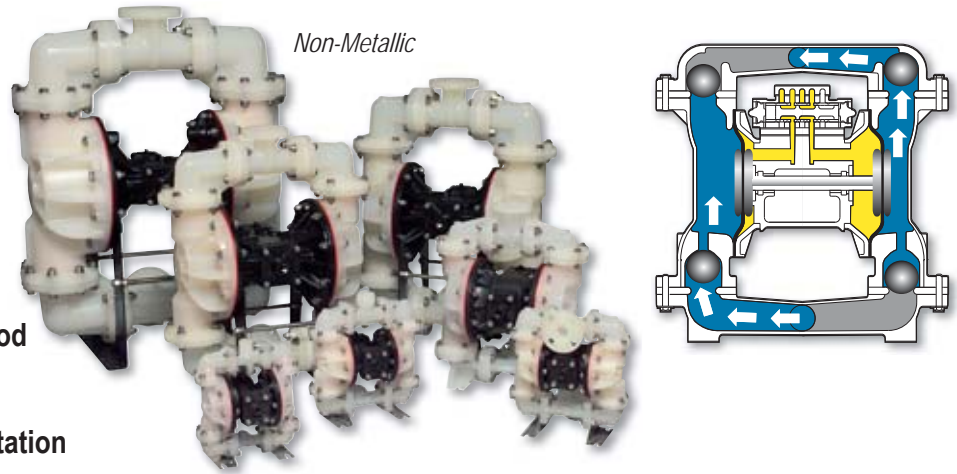

CHARACTERISTICS CHART:

		Standard Duty Top Discharge	
		Metallic	Non-Metallic
Fluid Characteristics	Water (base reference)	A	A
	Suspended Solids	A	B
	Non-Suspended Solids	C	X
	Line Size Solids	X	X
	Sludge / Slurry	B	C
	High Viscosity (Flowable Fluids)	B	B
	Erosion / Abrasive Fluids	High	B
Moderate		B	C
Low		A	B
	Corrosion	B	A
Installation	Permanent	B	B
	Portable	A	A
	Containment / Prevention	C	C
	Flooded Suction	B	B
	Suction Lift	B	B
	Submerged	B	C
Duty	Intermittent / On-Demand	A	A
	Continuous	B	B

A = Best Type C = Caution (Limitations)
 B = Suitable X = Unsuitable

CURVES :

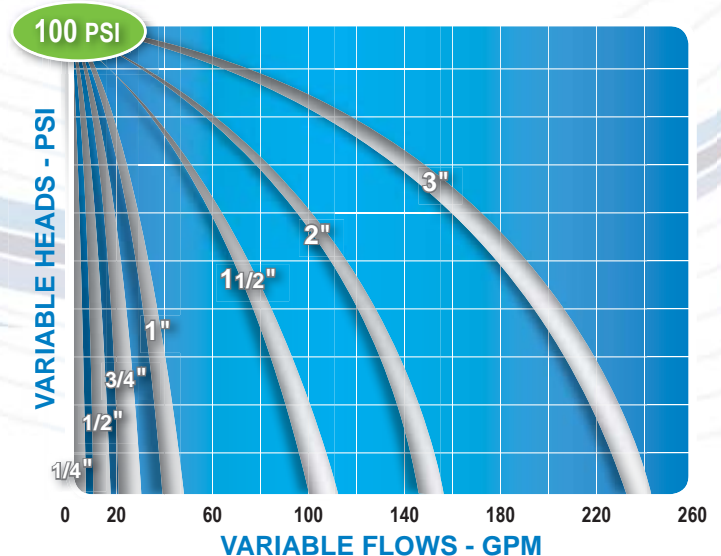

BEST PRACTICES

Recommended process control loop accessory components.

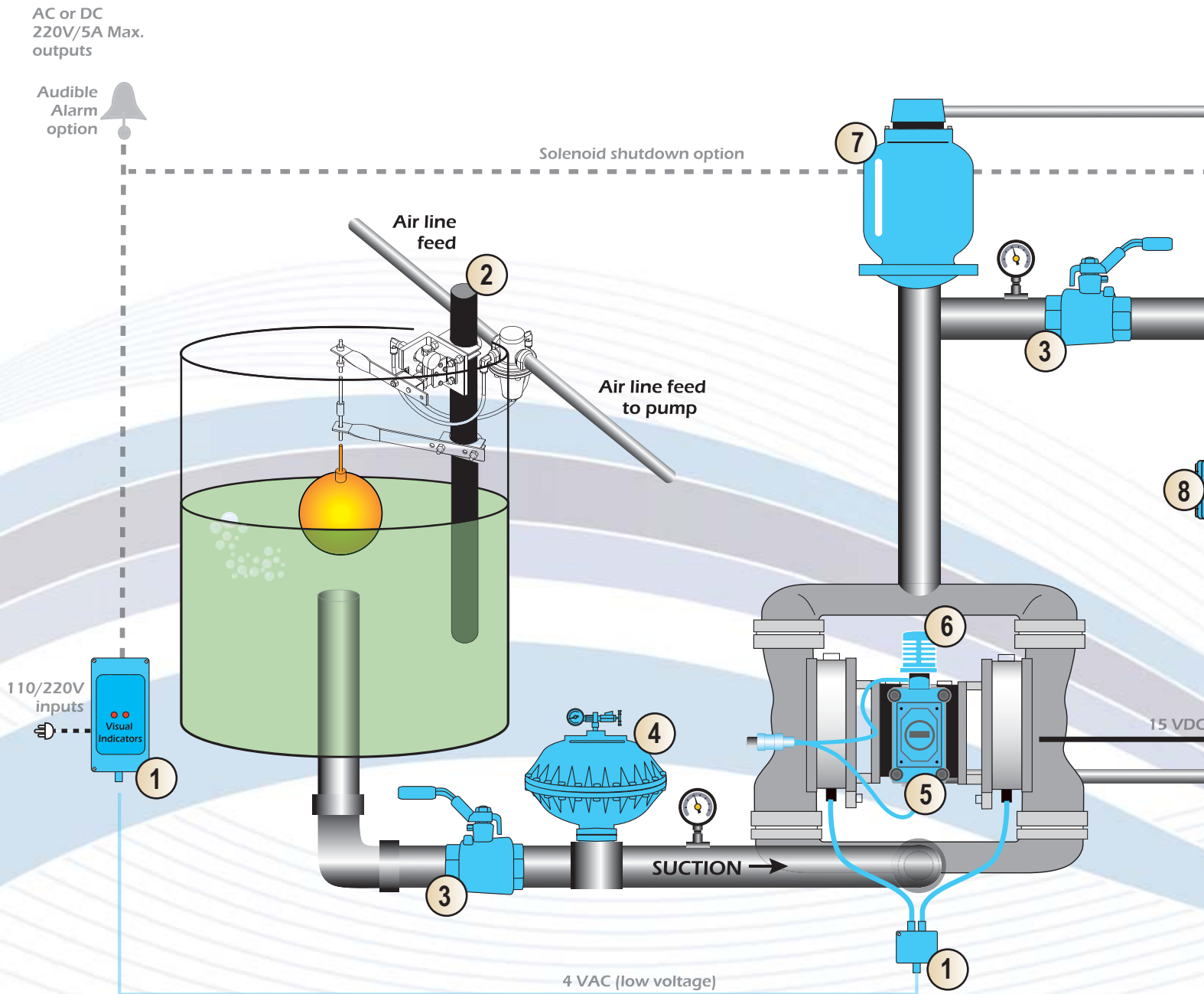

1. Leak Detection

2. Liquid Level Controls

3. Banjo® Ball Valve

4. Blacoh® Inlet Stabilizer

5. Pulse Output Kits

6. Muffler Options

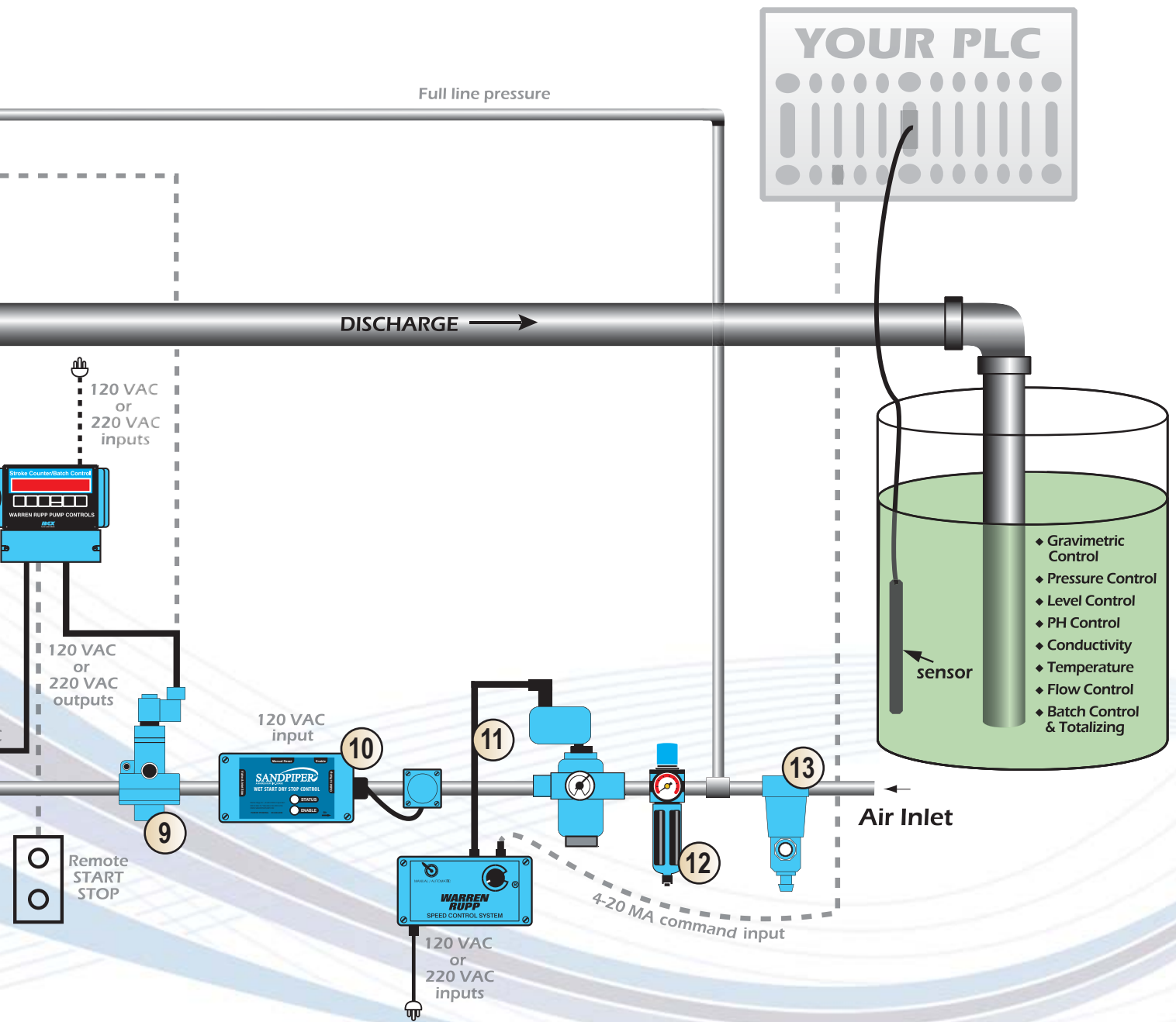

- | | |
|--|--------------------------------|
| 7. Tranquilizer® (Surge Dampeners)
Blacoh® Plastic Dampener | 10. Wet Start Dry Stop Control |
| 8. Stroke Counter/Batch Control | 11. Electronic Speed Control |
| 9. Air Line Solenoid | 12. Filter/Regulator |
| | 13. Air Dryer |

ACCESSORIES - PROCESS CONTROL LOOP

1. LEAK DETECTION



Part #
032.XXX.000

Electronic

At the point the primary pumping diaphragm fails, this modular, watertight unit senses conductivity changes between the driver fluid and the pumped fluid. Warning lights indicate which side of the pump is tainted. The unit can also be wired for audible alarm or pump shutdown. Low voltage. Simple installation.

Visual

A sight tube style leak detector is installed on each driver chamber. If a pumping diaphragm break occurs, liquid in the sight tube changes. This type of leak detection is standard construction on non-metallics spill containment pumps.



Standard



Part #
031.XXX.110

Mechanical

When a leak chemically attacks an internal o-ring on this detector, it actuates a plunger. This opens an air valve, which in turn activates a customer-supplied solenoid (or similar device) to trigger a signal. For use with the CONTAINMENT DUTY Spill Containment SANDPIPER® pumps ONLY.

2. LIQUID LEVEL CONTROLS

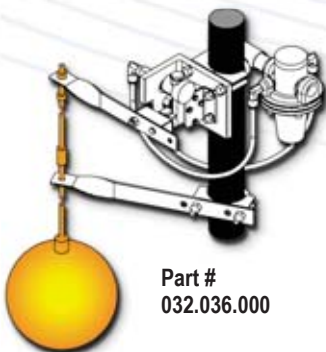

Part #
032.036.000

SANDPIPER's float actuated liquid level control provides all-pneumatic operation. Especially useful in sump and liquid transfer situations, the float actuated switch opens and closes air supply to the pump for positive ON-OFF response. High capacity air valve accommodates air flow requirements up to 125 cfm, with a pressure drop less than 10 PSI.

3. BANJO® BALL VALVE



Precision-molded Polypropylene ball valves are reinforced with fiberglass for additional strength.



316 Stainless Steel two-piece ball valves have blow-out proof stems and are rated at 1000 PSI.

Both Polypropylene and Stainless Steel have PTFE seals and seats. Tank accessories include 150# ANSI flanges and ANSI flange gaskets in both EPDM and FKM.

4. BLACOH® SENTRY®/INLET STABILIZER

Blacoh's® SENTRY® Inlet (Suction) Stabilizers at the pump's inlet reduces pressure fluctuations and aids in filling the pump head with fluid during each inlet stroke. In high suction lift applications, SENTRY® Inlet Stabilizers will momentarily maintain the flow of the accelerated fluid.



5. PULSE OUTPUT KITS

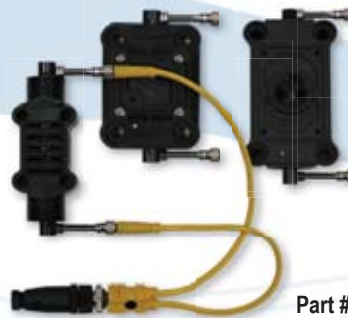

Part # 475.000.000

Offered in a wide variety of sizes and voltages. These controls interface with the SANDPIPER Batch Controller, or your own process controls (PLC's). Available in kits, for field installation, or factory built into a new pump.

Refer to Service Manuals & Data Sheets for ATEX Compliance.

6. MUFFLER OPTIONS

Effective sound dampening for SANDPIPER pumps. Mufflers are a rugged Polymer or metallic housing. Sound dampening and encapsulated mufflers have replaceable acoustic composite inserts. All SANDPIPER pumps are supplied with a basic muffler. Meets OSHA dBA requirements.



Part #
530.XXX.000

7. TRANQUILIZER®/DAMPENERS

Metallic Surge Suppressors

For use with any reciprocating pump, Tranquilizer surge suppressors maintain a constant air cushion volume in a pumping application for the most effective surge suppression. All Tranquilizer models are automatically self-charging and self-venting. Flexible diaphragm separates air cushion from pumped product.



Part # TA-1, TA-1½, TA-2, TA-3

Non-Metallic Surge Dampeners

Designed for use with ½", ¾" and 1" pumps, these dampeners are manually charged with air. PTFE diaphragms are standard, with wetted parts available in Polypropylene, PVDF, and Nylon. The DA05 is also available in Aluminum and Stainless Steel. Flow and pressure fluctuations are minimized, the dampener consumes no air after initial charging. Hardware is 302/304 Stainless Steel.



Part # DA05, DA07 & DA10

Blacoh® SENTRY® Plastic Pulsation Dampeners

These dampeners remove virtually all hydraulic shock, enhancing all-around performance and reliability of fluid handling equipment in industrial and chemical transfer applications.



8. STROKE COUNTER/BATCH CONTROL

Transforms your diaphragm pump into an accurate, controllable pump system. User-friendly control systems for your new or existing pumps. It eliminates troublesome and expensive flow-sensing devices. The Stroke Counter/Batch Control is an interfaceable electronic control to program repetitive diaphragm pump operations. This industrial-grade control offers performance and repeatability. Compatible with all SANDPIPER air-operated diaphragm pumps. The control unit functions as a batch control, a stroke counter, or both. The complete system requires the Stroke Counter/Batch Controller, the Pulse Output Kit & the Air line Solenoid.



Part # 249.006.000

9. AIR LINE SOLENOID

Provides automatic on/off operation of air-driven equipment. 110/120VAC and 220/240VAC (50/60 hertz) kits operate with the SANDPIPER or customer's control units. 12VDC and 24VDC kits operate with customer-supplied controls only.



Part # 894.XXX.000

10. WET START DRY STOP CONTROL



Part # 032.066.000

SANDPIPER is pleased to offer a more intelligent way to control AODD pumps. The Wet Start Dry Stop device monitors the flow of air into a pump to detect loss of prime or dry run conditions and will automatically restart and check for prime. The device identifies when a pump breaks prime and shuts off the pump, resulting in a lower cost of ownership, lower maintenance and less money spent on wasted compressed air.

11. ELECTRONIC SPEED CONTROL

Easy installation and operation. Fits most air-operated diaphragm pumps with operating pressures to 125 PSI.

Accurate control of variable flow rates, from zero flow to maximum. Operates on 110 or 220VAC. Manual operation with on-board, single turn potentiometer or automatic mode for remote control using the optional 4-20 mA input terminal. Speed Control System can be integrated with existing process control systems.



Part # 032.XXX.000

12. FILTER/REGULATOR

Clean, dry air is the key to trouble-free pump operation. The SANDPIPER Filter/Regulator line offers modular convenience for easy installation and service.



Part # 020.XXX.XXX

13. AIR DRYER



This point-of-use air dryer is designed to remove 99% of the water, rust and other contaminants commonly present in compressed air lines. Clean, dry air enhances the life and performance of pneumatically-driven equipment.

Part # 020.XXX.XXX

Surge Suppression for AODD Pumps

- Virtually surge-free flows
- Steadier pressures
- Less vibration and noise
- Simple installation
- Variety of sizes and materials
- Automatically self-charging and self-venting
- Longest life balanced diaphragm

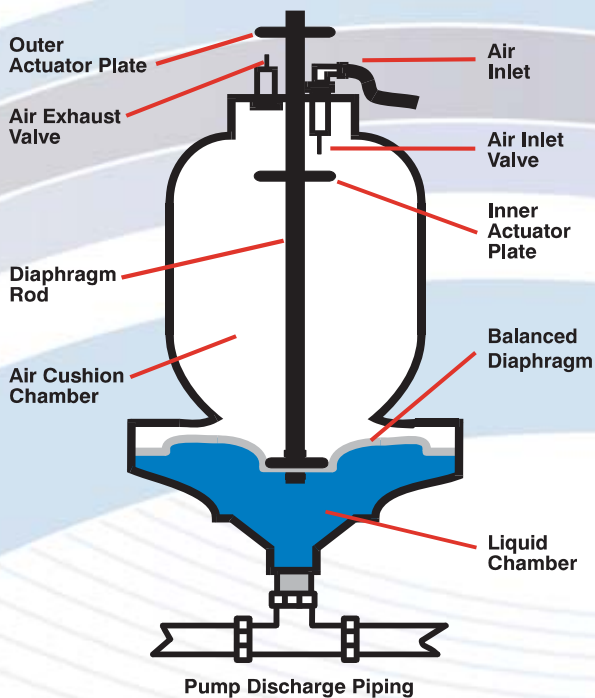

TA1½

TA1

TA3
DL2

TA2
DL2

OPERATING PRINCIPLE

An air cushion is established by liquid pressure pushing the diaphragm upward. This allows air to enter the chamber. The balancing air cushion keeps the diaphragm centered at mid stroke.

During operation, the diaphragm(s) flex within the mid-range position, absorbing and equalizing discharge surge.

If pressure changes in the system, the air cushion pressure compensates, automatically increasing or decreasing. If liquid pressure is released, air in the suppressor chamber exhausts into the atmosphere.

Properly sized and installed, Tranquillizers provide virtually surge-free discharge flow.

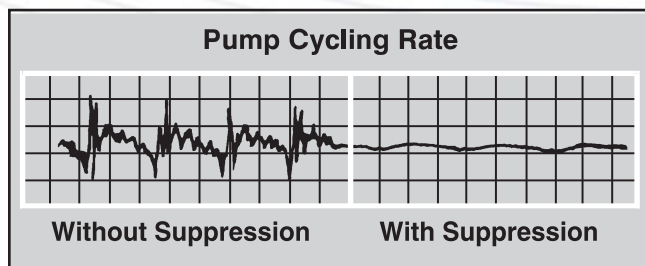

ACCESSORIES - DRUM PUMP



Part #
475.196.XXX

Part # 031.091.000

Pail & Drum Kits

Converting our ¼", ½" and ¾" plastic pumps to a drum or pail application is easy. The adaptor kits are constructed of chemically-resistant materials to handle the job. Plastic pipe assembly comes complete with all the hardware needed. Simply attach the threaded end to the suction manifold and lower it into the liquid source.

The 55-gallon Drum Transfer Kit includes pump support legs to minimize the vibration occurring in a diaphragm pump.

The 120# Barrel Transfer Kit includes a lid with adjustment screws for a snug fit every time.

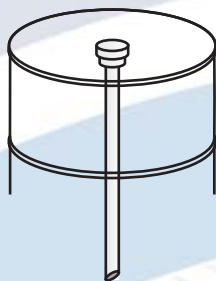

Part #
475.149.XXX
475.150.XXX
475.151.XXX
475.194.XXX
475.195.XXX



The Pail Transfer Kit also includes a lid with adjustment screws, plus handles for easy mobility.



Pail mounted SANDPIPER® Pumps installed on paint spray booth station.

OEM SOLUTIONS

SANDPIPER offers existing products, modified products and custom built products. Whether you need private labeling, special accessories, or an entire system, let our experienced staff assist you in meeting your special requirements.

■ STANDARD

Special blanket pricing available on standard pumps in larger quantities.

■ SPECIAL

Special material combinations, construction, painting and labeling.

■ CUSTOM

Custom built, multi-pump systems. Customized shipping materials and fixtures to fit your manufacturing process.

■ ENGINEERING SERVICES

- Experienced Engineering staff
- Latest Cad/Cam design equipment with 3-D modeling
- Cad library
- Precise laboratory test equipment

■ TECHNICAL SERVICES

- Experienced staff for technical support
- Available in-house and field service analysis
- Worldwide support

■ MANUFACTURING SERVICES

- Latest in CNC capabilities
- Quick turnaround to meet customer scheduling needs
- Just-in-time scheduling available
- Custom packaging
- Fabrication experience

■ FLEXIBLE KANBAN AGREEMENTS

WR10 3/8" AODD OEM Pump

BENEFITS:

- Flows to 5 GPM (19 LPM)
- Multiple mounting positions
- Similar envelope dimensions to a standard 1/4" pump, but almost double the flow rate
- Cost competitive
- Dependable operation
- Size ideal for OEM applications

APPLICATIONS:

- Car Wash Chemicals
- Wash Solutions
- Dispensing of:
 - Pigments • Inks • Paints
 - Additives • Sanitizers
- Drum Transfer



WR10

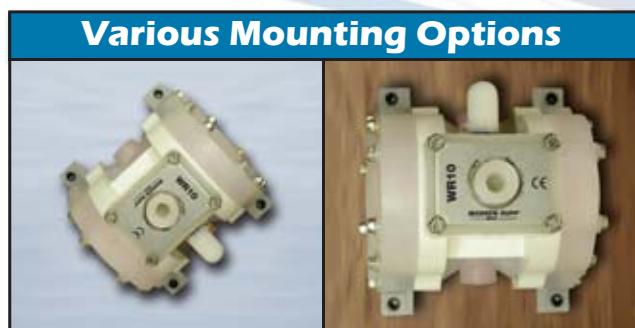

Various Mounting Options

Ceiling mount

Wall mount

WR10 SPECIFICATIONS		
Shipping wt.	3 lbs.	1.36 kg
Max. pressure	100 psi	6.9 bar
Min. pressure	15 psi	1 bar
Max. particle size	1/16"	1.5 mm
Suction lift (dry)	16.5 ft.	5m
Suction lift (wet)	20 ft.	6m
Air inlet	1/4" NPT (f)/BSP	
Materials: Polypropylene body with Santoprene elastomers; Polypropylene body with PTFE elastomers; PVDF body with Santoprene elastomers; PVDF body with PTFE elastomers		

HEAVY DUTY BALL

HDB3
Bottom Ported

HDB4
Top Ported

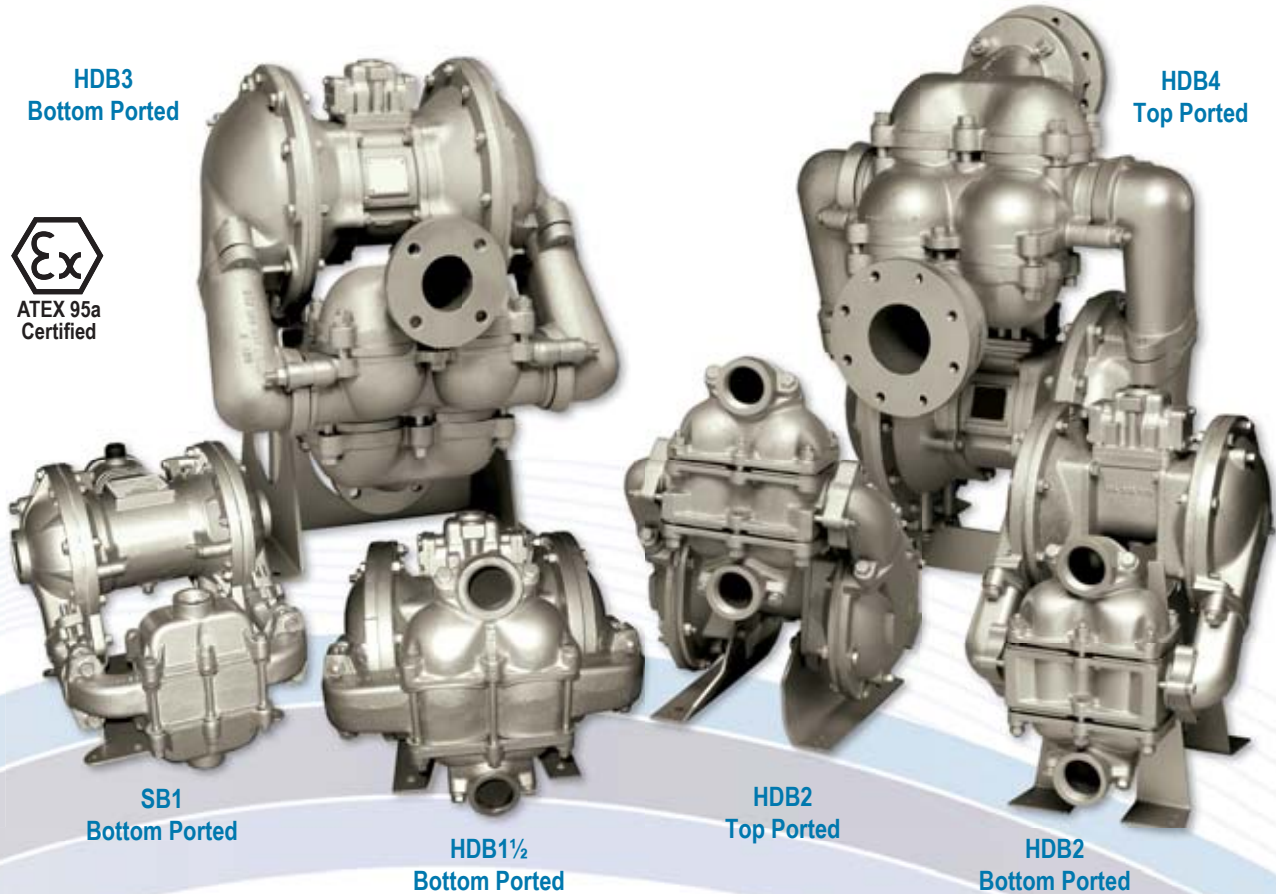

HDB Metallic Pumps are ideal for thin to highly viscous and small solids-laden fluids. SANDPIPER® Heavy Duty Ball Valve Pumps provide excellent suction lift capability and exclusive variable porting options (side, top, bottom and dual). HDB pumps are thick wall constructed of Sand Casted Aluminum, Cast Iron, Stainless Steel or Alloy C with elastomer, TPE (thermal plastic elastomers) and PTFE options in diaphragms and check valves. HDB pumps are enhanced with an extended wear package.



3" HDB bottom ported pump installed as a plate & frame filter press, pre-coat supply pump.

DIMENSIONAL DETAIL

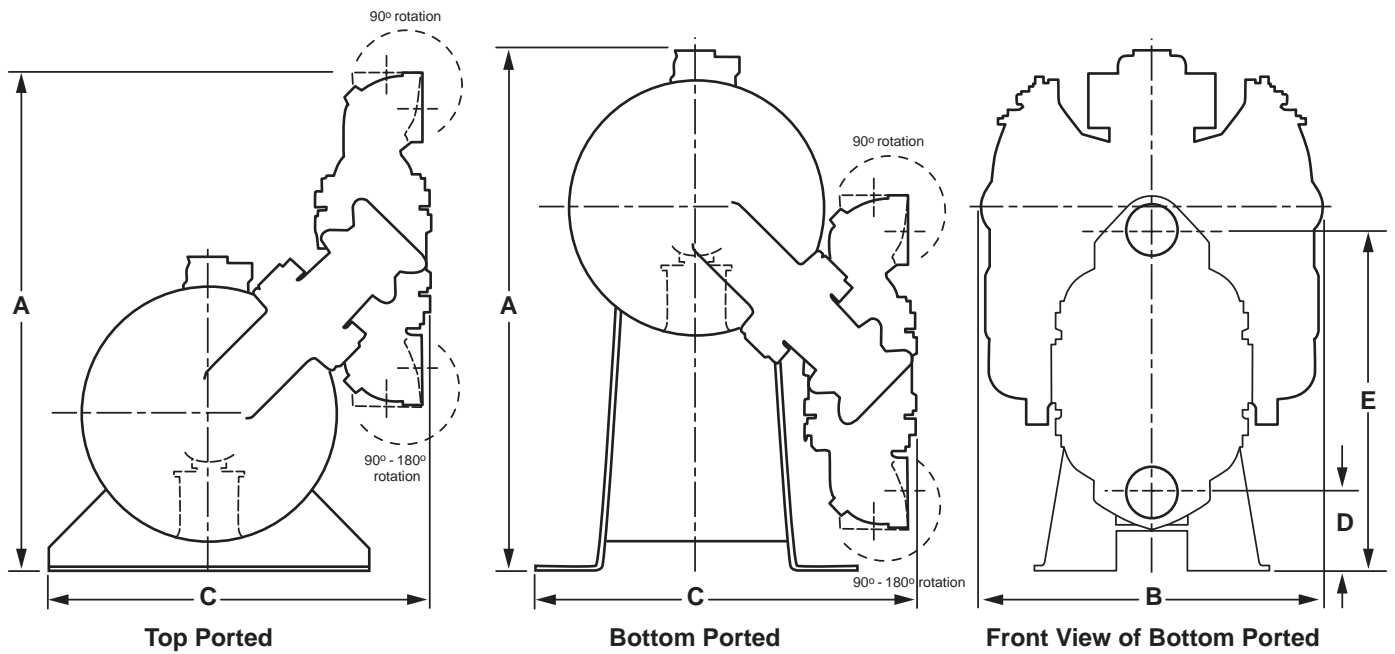

HEAVY DUTY BALL

PUMP MODELS	A	B	C	D		E	Connection Style	Pipe Size	Displacement Per Stroke	Max Flow Per Minute	Max Solids Handling	Max Discharge Pressure
	Height	Width	Depth	Bottom of Base to Center Line of: Suction		Discharge						
	inches (mm)	inches (mm)	inches (mm)	inches (mm)	inches (mm)	inches (mm)						
SB1/SB25	14 7/16 (367)	11 3/4 (298)	13 9/32 (337)	5 1/4 (133)	13 (330)	1" NPT/BSP	1 (25)	.09 (.34)	42 (159)	.25 (6)	125 (8.6)	
SB1 TOP	13 1/2 (342)	11 3/4 (298)	14 7/8 (378)	5 5/8 (142)	13 1/2 (342)	1" NPT/BSP	1 (25)	.09 (.34)	42 (159)	.25 (6)	125 (8.6)	
SB1 BOTTOM	13 11/16 (347)	11 3/4 (298)	14 7/8 (378)	27/32 (21)	8 7/16 (214)	1" NPT/BSP	1 (25)	.09 (.34)	42 (159)	.25 (6)	125 (8.6)	
HDB1½ TOP	19 7/32 (488)	15 1/2 (419)	17 (432)	8 9/64 (207)	18 5/64 (459)	1½" NPT/BSP	1.5 (40)	.34 (1.29)	90 (340)	.25 (6)	125 (8.6)	
HDB1½ BOTTOM	18 9/16 (471)	15 1/2 (419)	17 (432)	6 9/64 (156)	16 (406)	1½" NPT/BSP	1.5 (40)	.34 (1.29)	90 (340)	.25 (6)	125 (8.6)	
HDB2 TOP	22 3/16 (564)	15 1/2 (394)	16 13/16 (427)	9 1/8 (232)	20 7/8 (530)	2" NPT	2 (50)	.43 (1.63)	135 (511)	.38 (9)	125 (8.6)	
HDB2 BOTTOM	23 1/4 (591)	15 1/2 (394)	16 13/16 (427)	3 7/16 (87)	15 3/16 (386)	2" NPT	2 (50)	.43 (1.63)	135 (511)	.38 (9)	125 (8.6)	
HDB3 TOP	37 1/8 (943)	26 (661)	20 3/4 (527)	20 (509)	33 3/8 (848)	3" 125# ANSI	3 (80)	1.8 (6.81)	260 (988)	.87 (22)	125 (8.6)	
HDB3 BOTTOM	31 1/4 (794)	26 (661)	24 5/8 (625)	5 3/4 (146)	19 3/8 (492)	3" 125# ANSI	3 (80)	1.8 (6.81)	260 (988)	.87 (22)	125 (8.6)	
HDB4 TOP	37 7/8 (962)	26 (661)	23 3/4 (603)	20 (509)	33 3/8 (848)	4" 125# ANSI	4 (100)	1.8 (6.81)	260 (988)	.87 (22)	125 (8.6)	
HDB4 BOTTOM	31 1/4 (793)	26 (661)	27 1/2 (699)	5 3/4 (146)	19 3/8 (492)	4" 125# ANSI	4 (100)	1.8 (6.81)	260 (988)	.87 (22)	125 (8.6)	

All Dimensions +/- 1/8 (3)

HEAVY DUTY BALL

HEAVY DUTY BALL

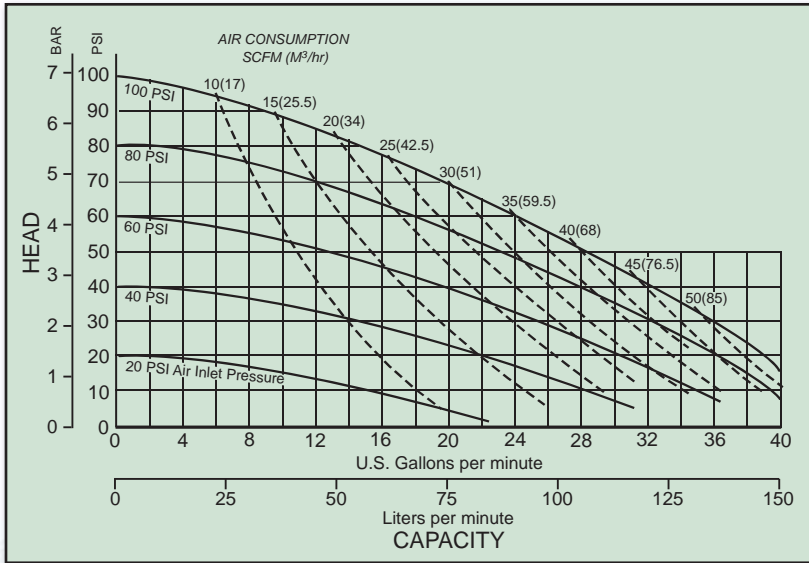

SB1
Performance Curve

HDB1½
Performance Curve

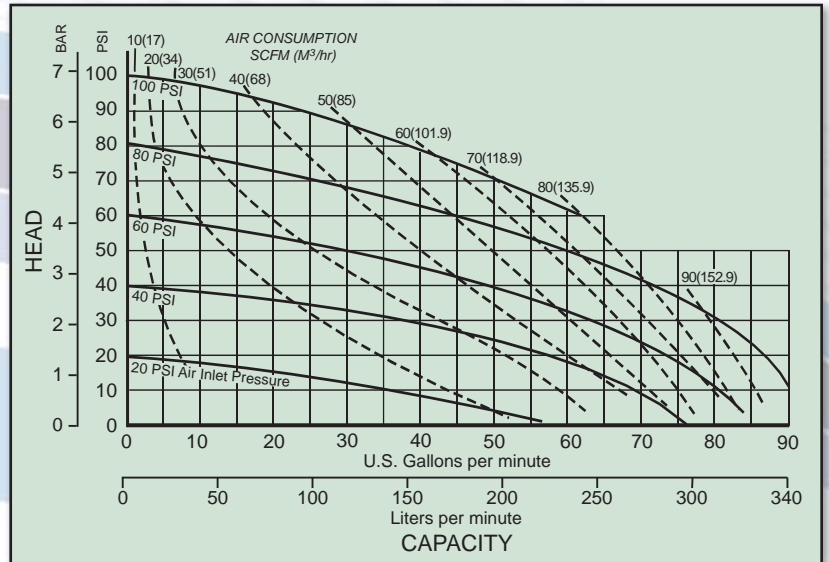

HDB bottom discharge ported pumps with tranquilizers installed at an industrial waste treatment facility.



1" ball valve pumps installed in a paint mixing and tinting operation.

HEAVY DUTY BALL

HDB2
Performance Curve

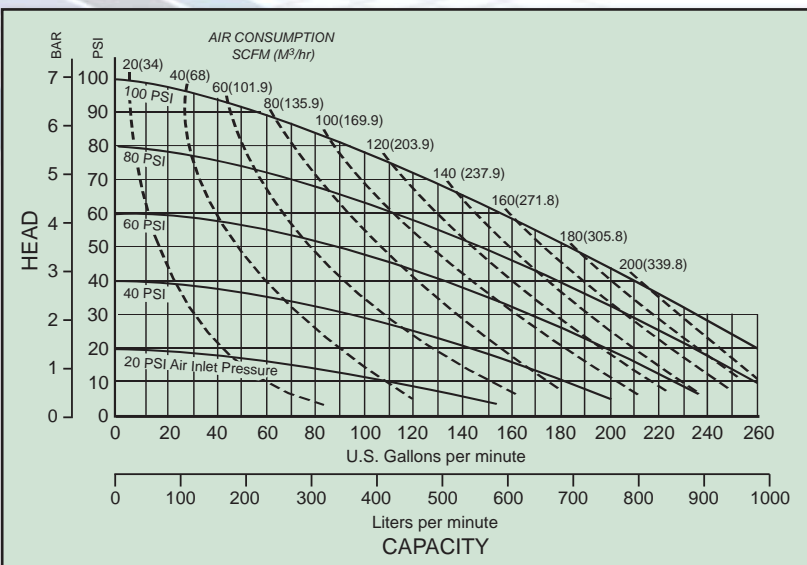
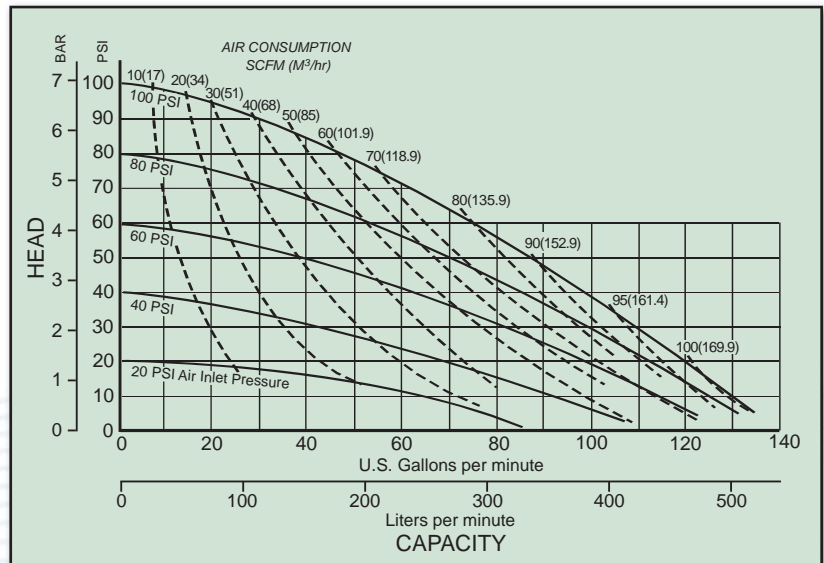

HDB3 & HDB4
Performance Curve

HEAVY DUTY FLAP

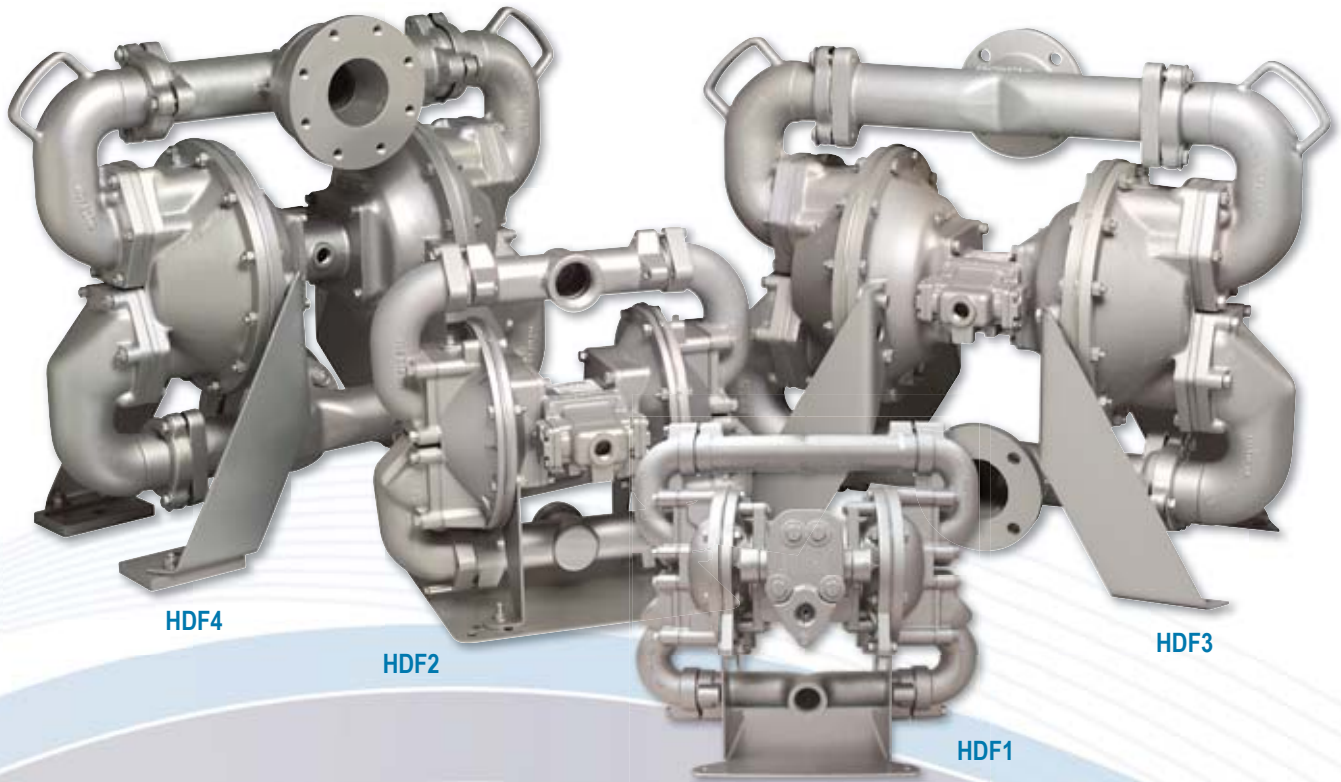

HEAVY DUTY FLAP

HDF Pumps are recommended for abrasive slurries, suspended and non-suspended solids and line-size solids requirements. All SANDPIPER® Heavy Duty Flap Valve pumps are configured in bottom discharge porting arrangements and provide superior suction lift. HDF pumps are thick wall constructed of Sand Casted Aluminum, Cast Iron and Stainless Steel with elastomer, TPE (thermal plastic elastomers) and PTFE options in diaphragms and check valves. HDF pumps are enhanced with an extended wear package.



Heavy duty flap valve pumps with tranquilizers permanently installed in an automotive industrial waste treatment facility.

DIMENSIONAL DETAIL

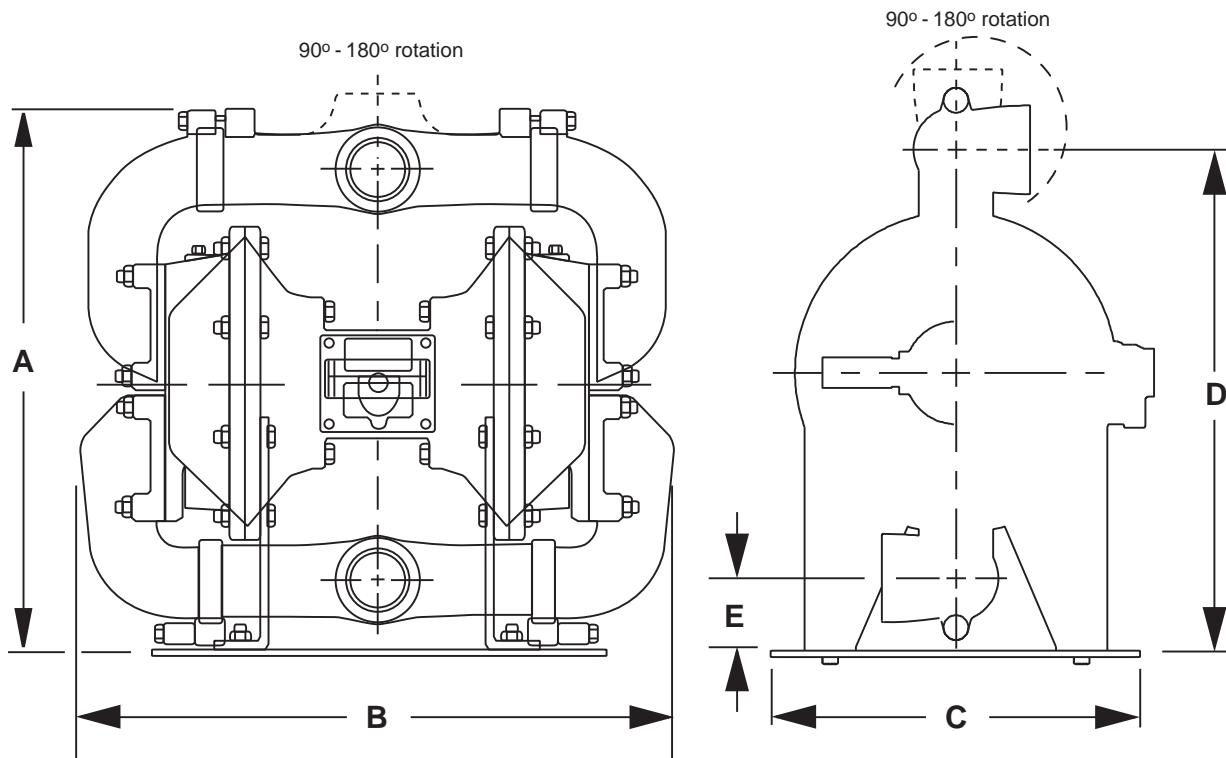

Bottom Discharge Ported

HEAVY DUTY FLAP

PUMP MODELS	A	B	C	D		Connection Style	Pipe Size	Displacement Per Stroke	Max Flow Per Minute	Max Solids Handling	Max Discharge Pressure
	Height	Width	Depth	Bottom of Base to Center Line of: Suction Discharge							
	inches (mm)	inches (mm)	inches (mm)	inches (mm)	inches (mm)						
HDF1	15 11/16 (398)	16 3/4 (425)	10 13/16 (274)	14 1/16 (356)	2 9/16 (65)	1" NPT/BSP	1 (25)	.10 (.38)	70 (265)	1 (25)	125 (8.6)
HDF2	20 5/16 (516)	21 3/4 (552)	13 5/8 (346)	17 11/16 (449)	2 9/16 (65)	2" NPT only	2 (50)	.43 (1.60)	140 (530)	2 (50)	125 (8.6)
HDF3	29 1/2 (749)	36 9/16 (929)	16 1/4 (413)	25 3/4 (654)	4 1/4 (108)	3" 125# ANS	3 (80)	1.62 (6.15)	260 (988)	3 (80)	125 (8.6)
HDF3-M	30 1/4 (768)	32 5/16 (821)	16 3/16 (411)	26 1/2 (673)	5 (127)	3" 125# ANSI	3 (80)	1.23 (4.66)	260 (988)	3 (80)	125 (8.6)
HDF4	31 (787)	36 9/16 (929)	21 1/4 (540)	26 1/2 (673)	5 (127)	4" 125# ANSI	4 (100)	1.62 (6.15)	260 (988)	3 (80)	125 (8.6)
HDF4-M	31 (787)	32 5/16 (821)	16 3/16 (411)	26 1/2 (673)	5 (127)	4" 125# ANSI	4 (100)	1.23 (4.66)	260 (988)	3 (80)	125 (8.6)

All Dimensions +/- 1/8 (3)

HEAVY DUTY FLAP

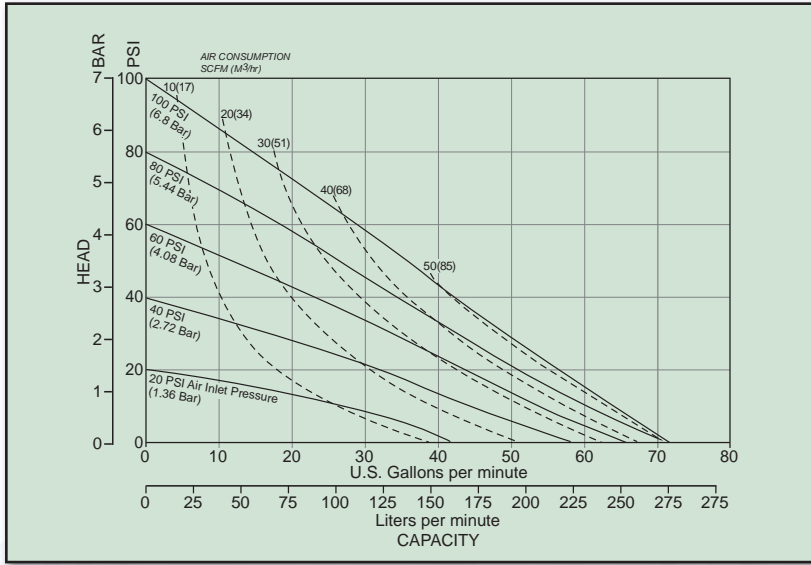

HDF1 Performance Curve

HEAVY DUTY FLAP

HDF2 Performance Curve

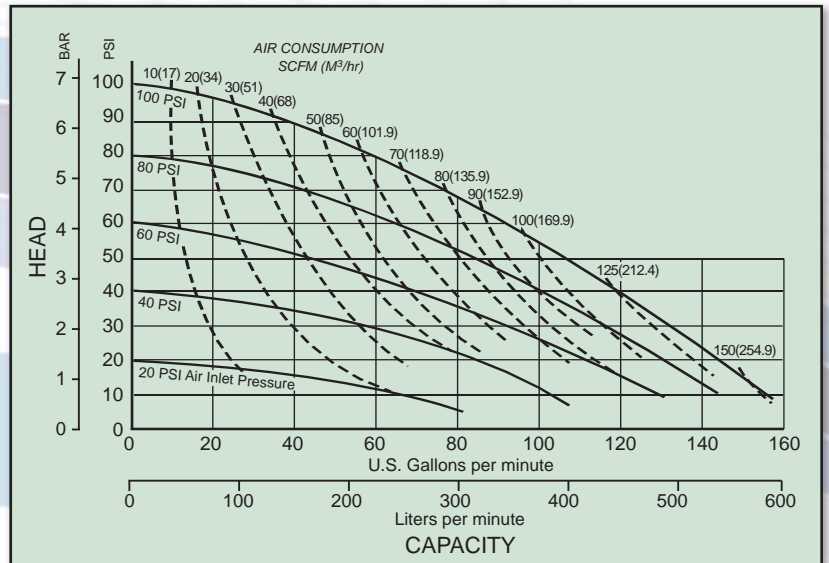

HDF3 & HDF4 Performance Curve

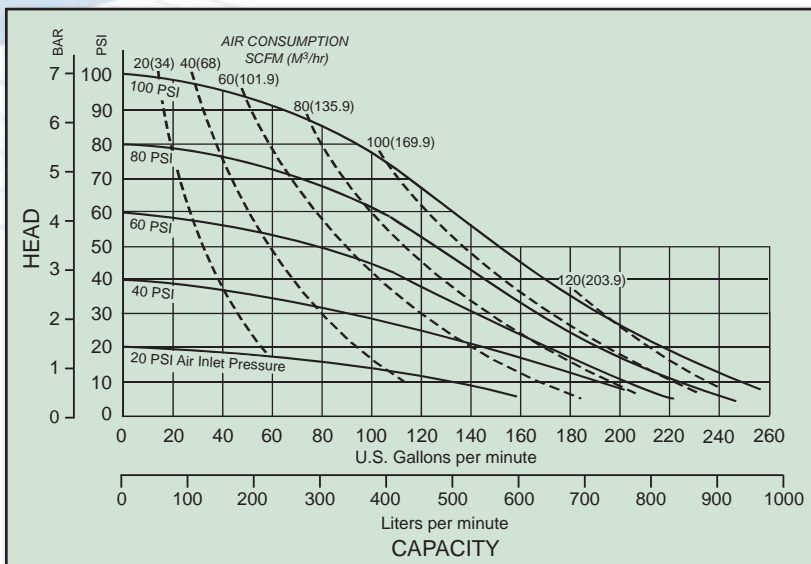

HDF3-M & HDF4-M Performance Curve

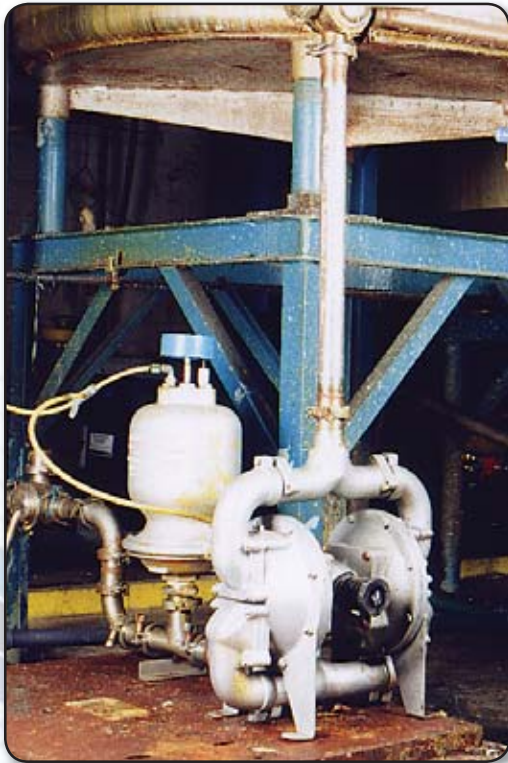
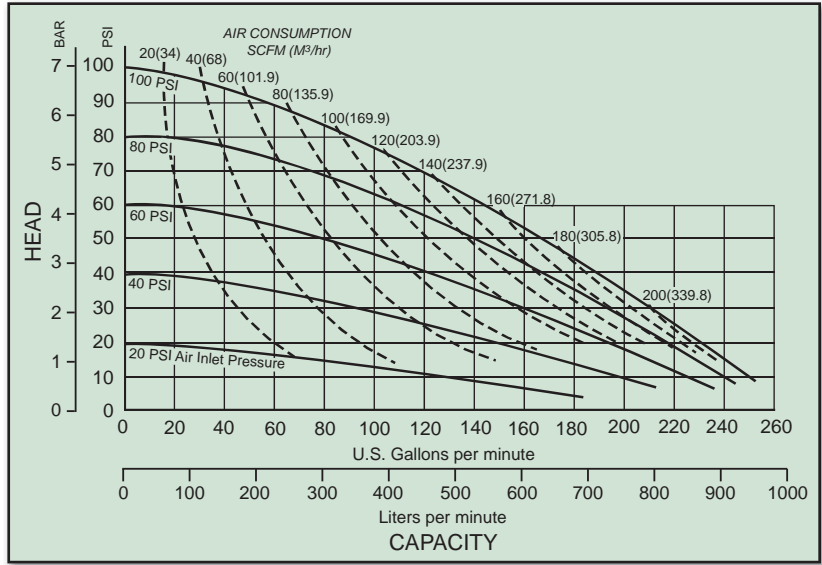

Heavy duty flap valve pump installed on an underflow sludge transfer application.

Heavy duty flap valve pump temporarily installed pumping settling pond sludge. (Perfect alignment not required).



CONTAINMENT DUTY BALL

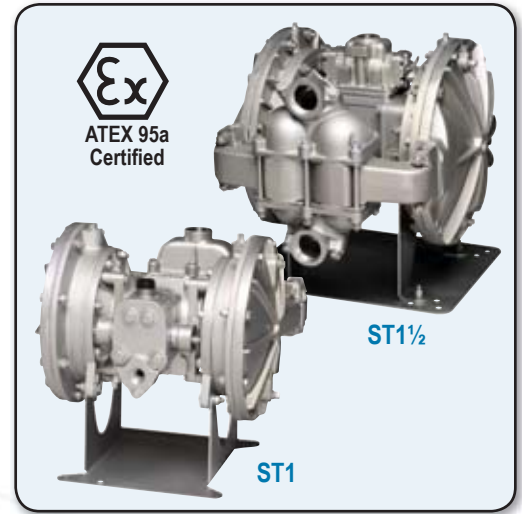
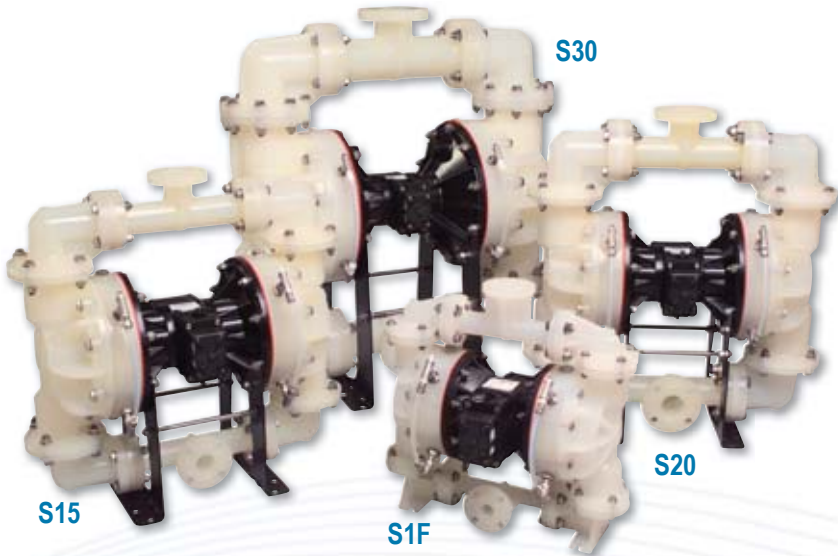

Containment Duty Metallic and Non-Metallic Pumps are ideal for highly corrosive and hazardous chemical fluid requirements. All CD duty pumps are exclusively designed with containment chambers, hydraulically balanced/coupled pumping diaphragm and driver diaphragm assemblies. All containment chambers are designed to accommodate visual, mechanical and low voltage leak detection devices. CD pumps are constructed of Aluminum, Cast Iron, Stainless Steel, Alloy C, Polypropylene and PVDF with TPE (thermal plastic elastomers), PTFE options in diaphragms and check valves.

Containment Duty Pumps additional FEATURES and BENEFITS

Spill Containment

- Safe pumping of aggressive, unpredictable, hazardous or toxic liquids.
- Chambers keep accidental spills from entering the air valve, protecting plant environment and personnel.
- Allows the pump to complete the batch or operation in progress, before repair has to be done.

Hydraulically Balanced/Coupled Diaphragms

- Pumping diaphragms are balanced on suction and discharge stroke.
- Evenly distributed pressure over the surface of the diaphragm gives longer flex life.

Save Money and Downtime

- Protects air valve parts from contamination, meaning fewer service parts and less maintenance time.
- Longer flex life of the diaphragm means less frequent routine servicing.

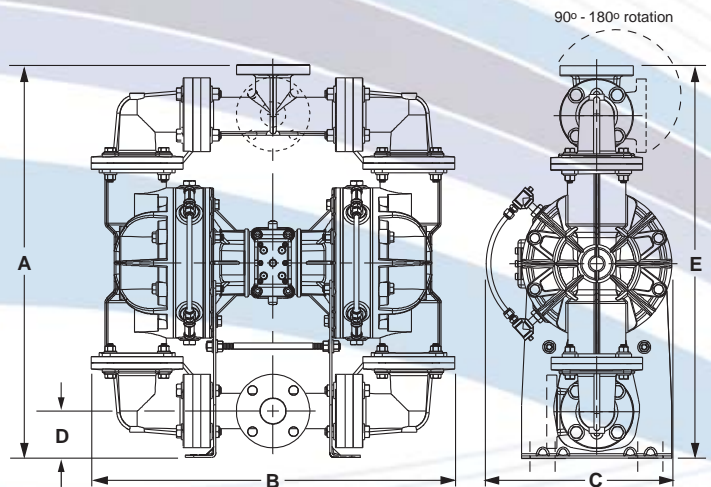

Leak Detection - See page 43

PUMP MODELS	A	B	C	D		E	Connection Style	Pipe Size	Displacement Per Stroke	Max Flow Per Minute	Max Solids Handling	Max Discharge Pressure
	Height	Width	Depth	Bottom of Base to Center Line of:		inches (mm)		inch (mm)	gal (liter)	gal (liter)	inch (mm)	psi (bar)
	inches (mm)	inches (mm)	inches (mm)	Suction	Discharge							
ST1/ST25	14 13/32 (366)	14 17/32 (369)	14 9/32 (363)	5 1/4 (133)	13 (330)	1" NPT/BSP	1 (25)	.09 (.34)	42 (159)	.25 (6)	125 (8.6)	
ST1½/ST40	17 1/2 (445)	16 1/2 (419)	18 5/8 (473)	5 9/32 (134)	15 15/64 (387)	1½" NPT/BSP	1.5 (40)	.30 (1.14)	90 (340)	.25 (6)	125 (8.6)	
S1F	20 3/4 (527)	21 3/4 (553)	12 1/16 (306)	2 1/2 (64)	20 3/4 (527)	1" 125# ANSI	1 (25)	.17 (64)	45 (170)	.25 (6)	100 (6.9)	
S15	28 11/16 (729)	28 5/8 (728)	15 1/4 (387)	3 1/2 (89)	28 11/16 (729)	1½" 125# ANSI	1.5 (40)	.36 (1.36)	100 (378)	.47 (12)	100 (6.9)	
S20	32 1/16 (814)	29 3/8 (746)	15 1/4 (387)	3 13/16 (96)	32 1/16 (814)	2" 125# ANSI	2 (50)	.36 (1.36)	160 (605)	.66 (17)	100 (6.9)	
S30	40 5/8 (1032)	37 15/16 (964)	19 5/8 (498)	4 7/8 (124)	40 5/8 (1032)	3" 125# ANSI	3 (80)	.9 (3.41)	238 (901)	.71 (18)	100 (6.9)	

All Dimensions +/- 1/8 (3)

LEAK DETECTION OPERATING PRINCIPLE

Electronic Leak Detection

How electronic leak detection works.

At a point the pumping diaphragm fails, pumped liquid enters the spill chamber displacing driver fluid. The leak detector, working on the principle of conductance, senses the conductivity change. This activates a warning light on the control box. The device can also be wired into the pump user's existing system, for an audible or visual alarm, or pump shut-down response. It is important to specify an appropriate drive fluid which is both chemically compatible with the pumped fluid and displays the opposite conductance properties. Polarity of the leak detector can be set to sense conductive or non-conductive fluid. If a leak occurs, pumpage is contained in the spill chamber. The pump will continue to work, and in many cases, repairs can be done when the batch is completed. The air valve and work environment are protected.



Visual Leak Detection

How visual leak detection works.

At a point the pumping diaphragm fails, pumped liquid enters the spill chamber, displacing driver fluid. The exchange of pumpage and driver fluid displays a color change in the sight tube, giving a visible signal. Driver fluid should be chemically compatible with the pumped fluid, with an obvious difference in color. In the event a leak occurs, pumpage is contained in the spill chamber. The pump will continue to work, and in many cases, repairs can be done when the batch is completed. The air valve and work environment are protected.

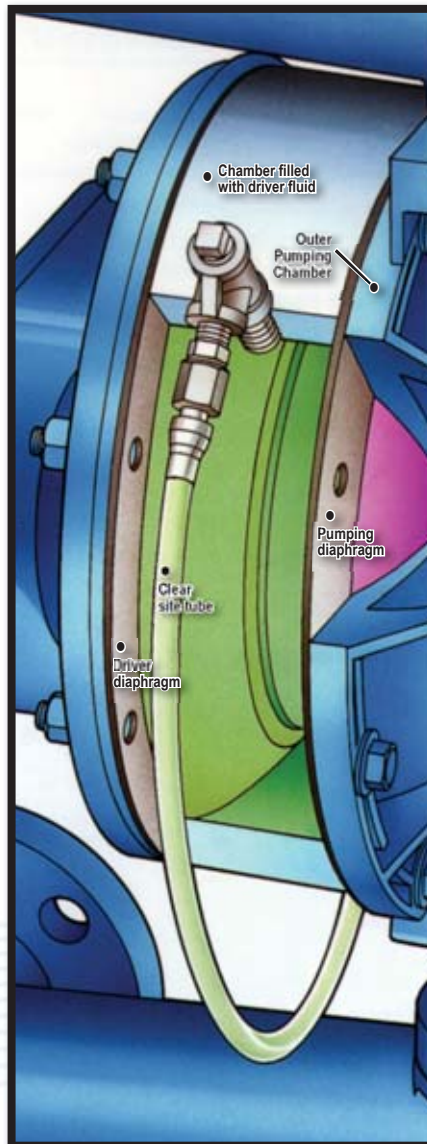

ELECTRONIC LEAK DETECTOR: Working on the principle of conductance, this monitor can be wired for visual, audible or pump shut-down response. The electronic leak detector is an optional accessory which can be installed on all models.



VISUAL LEAK DETECTOR: A sight tube style leak detector is installed on each driver chamber. If a pumping diaphragm break occurs, liquid in the sight tube changes color.



MECHANICAL LEAK DETECTOR: When a leak chemically attacks an internal o-ring on this detector, it actuates a plunger. This opens an air valve, which in turn activates a customer-supplied solenoid (or similar device) to trigger a signal.

CONTAINMENT DUTY

CONTAINMENT DUTY BALL

ST1 Metallic Performance Curve

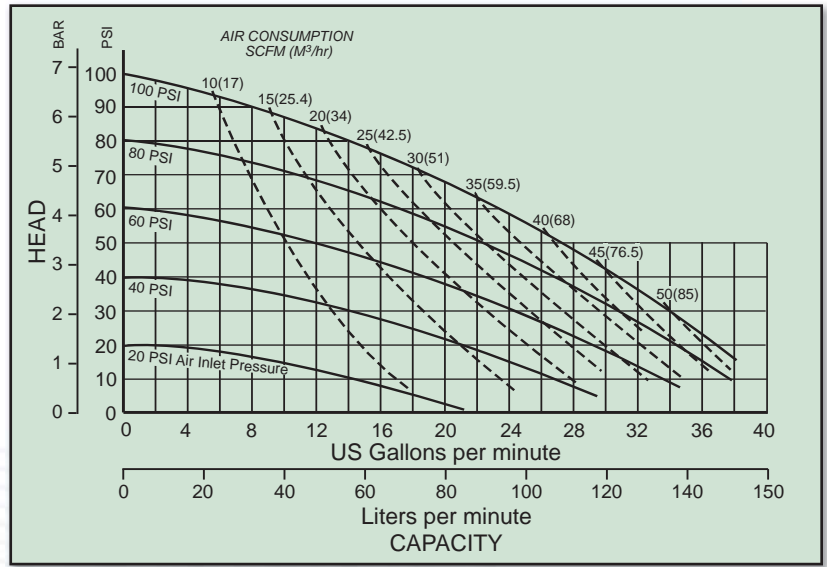

ST1½ Metallic Performance Curve

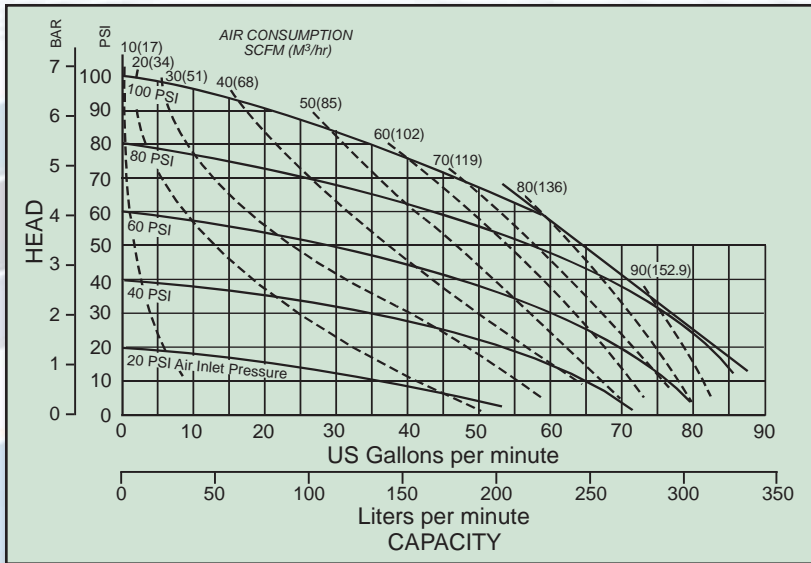

S1F Non-Metallic Performance Curve

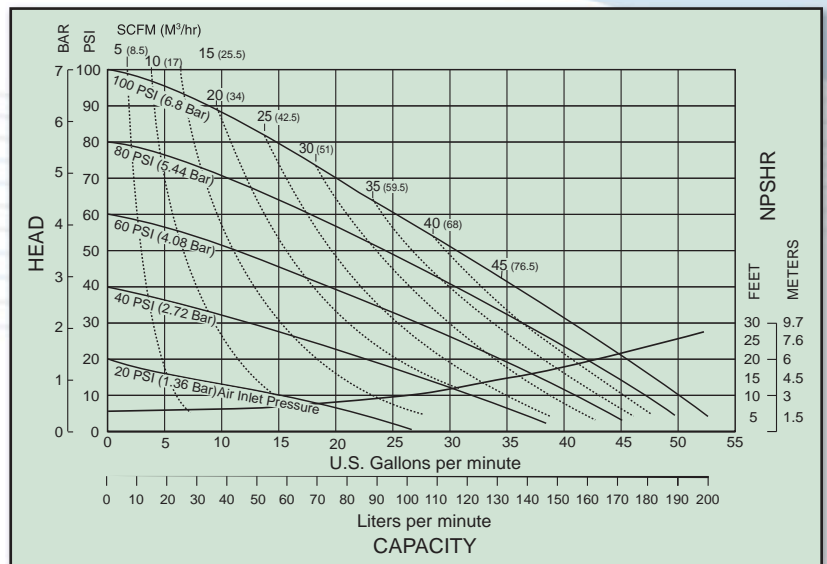

CONTAINMENT DUTY

S15 Non-Metallic Performance Curve

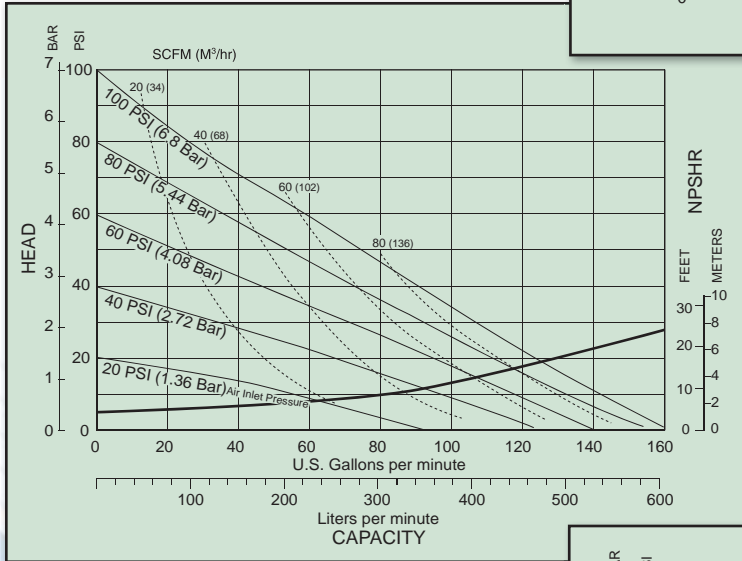
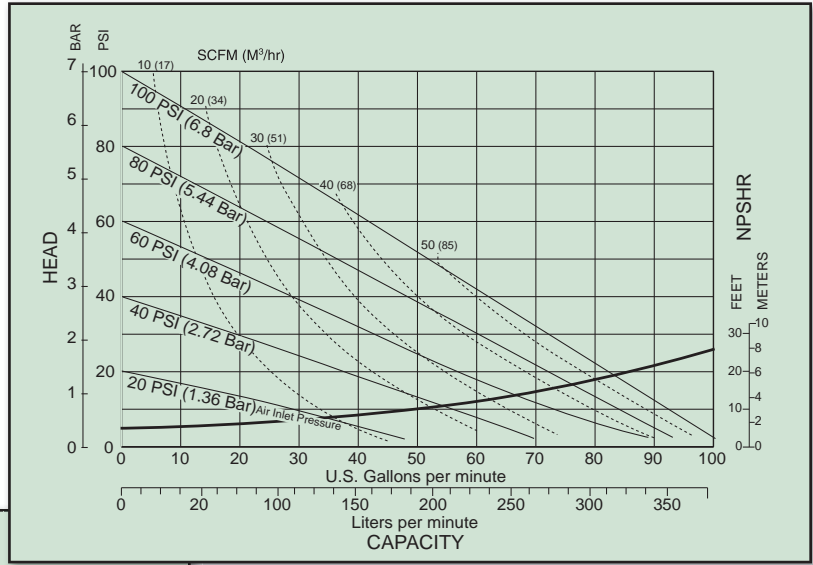

S20 Non-Metallic Performance Curve

S30 Non-Metallic Performance Curve

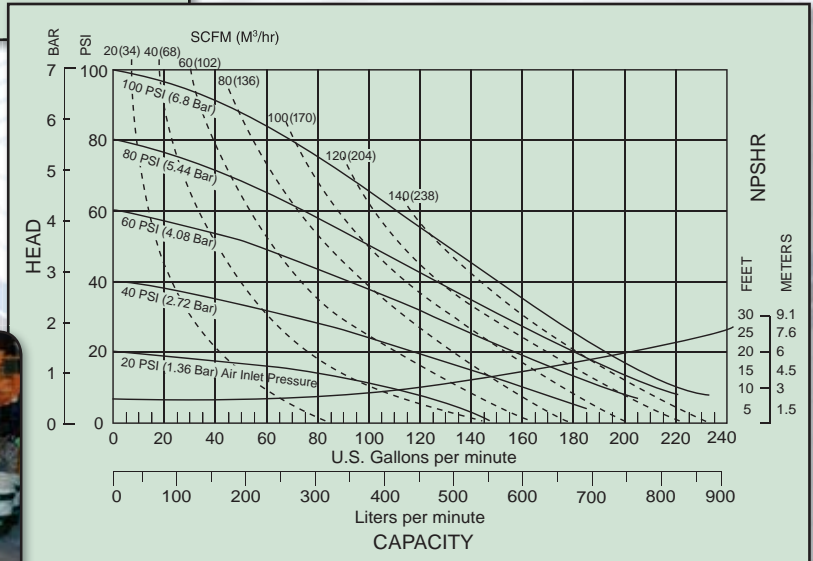

Metallic containment duty pumps and tranquilizers installed in a chemical processing plant.

CONTAINMENT DUTY

STANDARD DUTY BALL - METALLIC

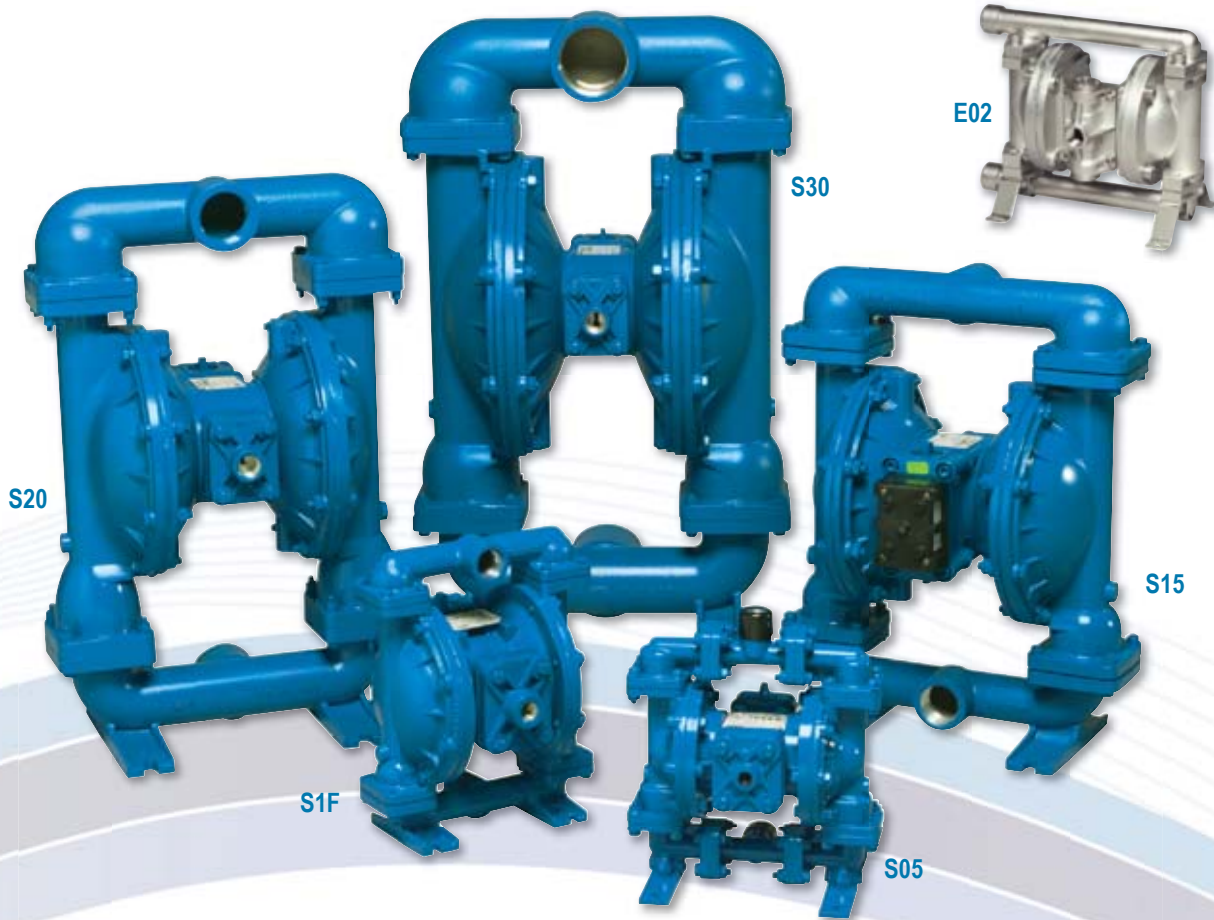

Standard Duty Metallic Pumps are ideally suited for intermittent/on-demand, portable, moderately abrasive fluids, and suspended solids. Standard duty metallic pumps are constructed in Aluminum, Cast Iron, Stainless Steel and Alloy C with elastomer TPE (thermal plastic elastomers) and PTFE options in diaphragms and check valves.



Metallic standard duty pumps handling suspended solids in an industrial waste treatment operation.

DIMENSIONAL DETAIL



Metallic standard duty pumps installed for exterior sump pumping requirements.

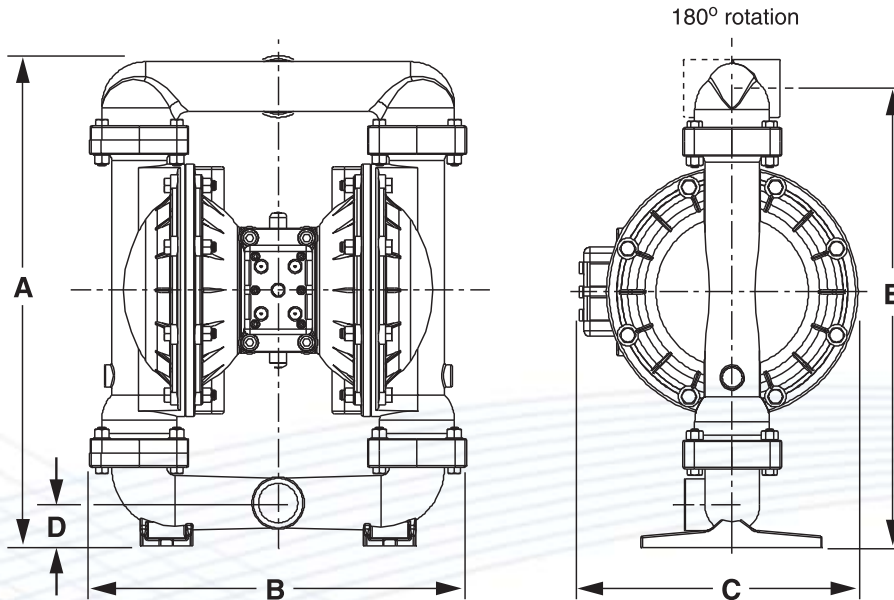

PUMP MODELS	A	B	C	D		Connection Style	Pipe Size	Displacement Per Stroke	Max Flow Per Minute	Max Solids Handling	Max Discharge Pressure
	Height	Width	Depth	Bottom of Base to Center Line of:							
	inches (mm)	inches (mm)	inches (mm)	Suction	Discharge						
E02	5 13/16 (148)	7 7/16 (189)	4 3/8 (111)	5/8 (16)	5 13/32 (138)	1/4" NPT/BSP	.25 (6)	.003 (.01)	4.4 (16.6)	.079 (2)	125 (8.6)
S05 AL	11 1/2 (292)	10 1/4 (260)	7 1/16 (179)	1 5/16 (33)	11 1/2 (292)	1" MNPT/BSP	.5 (13)	.026 (.098)	15 (57)	.125 (3)	125 (8.6)
S05 SS	10 3/8 (264)	10 1/4 (260)	7 1/16 (179)	1 5/16 (33)	9 23/32 (247)	1" MNPT/BSP	.5 (13)	.026 (.098)	15 (57)	.125 (3)	125 (8.6)
S1F AL / CI	12 23/32 (323)	10 1/4 (260)	10 3/8 (264)	1 3/32 (28)	11 27/32 (301)	1" NPT/BSP	1 (25)	.11 (.42)	45 (170)	.25 (6)	125 (8.6)
S1F SS	12 27/32 (326)	10 1/4 (260)	10 3/8 (264)	1 7/32 (31)	11 31/32 (304)	1" NPT/BSP	1 (25)	.11 (.42)	45 (170)	.25 (6)	125 (8.6)
S15 AL / CI	21 37/64 (548)	16 21/32 (423)	12 23/64 (314)	1 29/32 (49)	20 5/16 (516)	1 1/2" NPT/BSP	1.5 (40)	.41 (1.55)	106 (401)	.25 (6)	125 (8.6)
S15 SS	21 21/32 (550)	16 21/32 (423)	12 23/64 (314)	1 31/32 (50)	20 3/8 (518)	1 1/2" NPT/BSP	1.5 (40)	.41 (1.55)	106 (401)	.25 (6)	125 (8.6)
S20 AL / CI	26 5/16 (669)	16 7/8 (428)	12 19/32 (320)	1 7/8 (48)	24 5/8 (625)	2" NPT/BSP	2 (50)	.42 (1.59)	150 (567)	.25 (6)	125 (8.6)
S20 SS	26 5/16 (669)	16 7/8 (428)	12 19/32 (320)	2 (51)	24 3/4 (629)	2" NPT/BSP	2 (50)	.42 (1.59)	150 (567)	.25 (6)	125 (8.6)
S30 AL/CI	32 1/16 (814)	19 21/32 (499)	15 3/4 (400)	2 11/32 (60)	29 31/32 (761)	3" NPT/BSP	3 (80)	.94 (3.56)	238 (901)	.38 (9.5)	125 (8.6)
S30 SS	32 9/32 (820)	19 21/32 (499)	15 3/4 (400)	2 9/32 (65)	30 3/16 (767)	3" NPT /BSP	3 (80)	.94 (3.56)	238 (901)	.38 (9.5)	125 (8.6)

All Dimensions +/- 1/8 (3)

STANDARD DUTY

STANDARD DUTY BALL - METALLIC

S05 Metallic Performance Curve

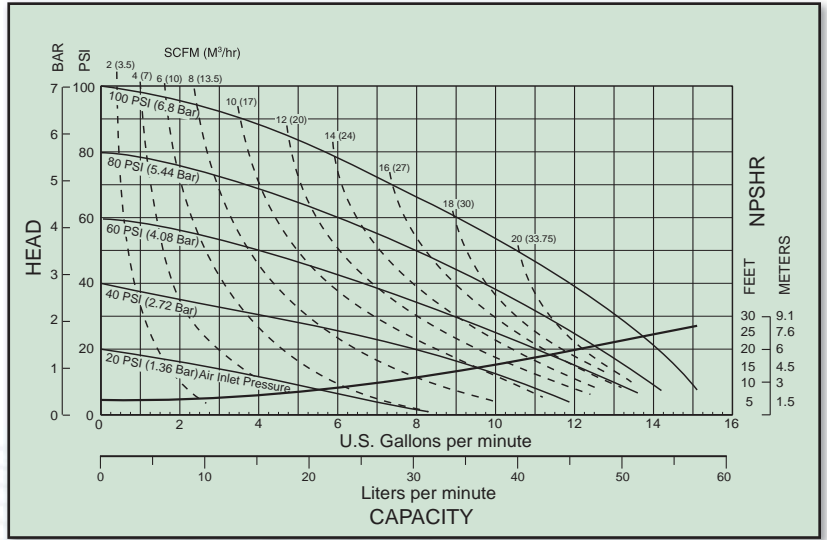

S1F Metallic Performance Curve

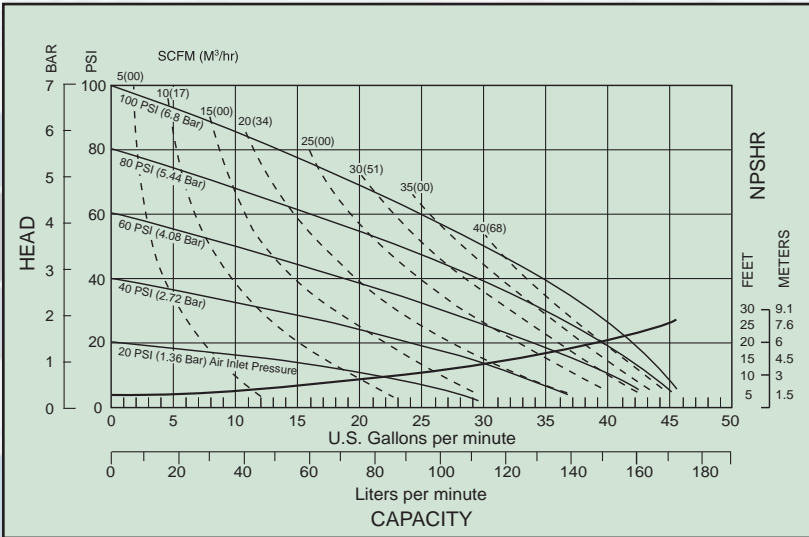

S15 Metallic Performance Curve

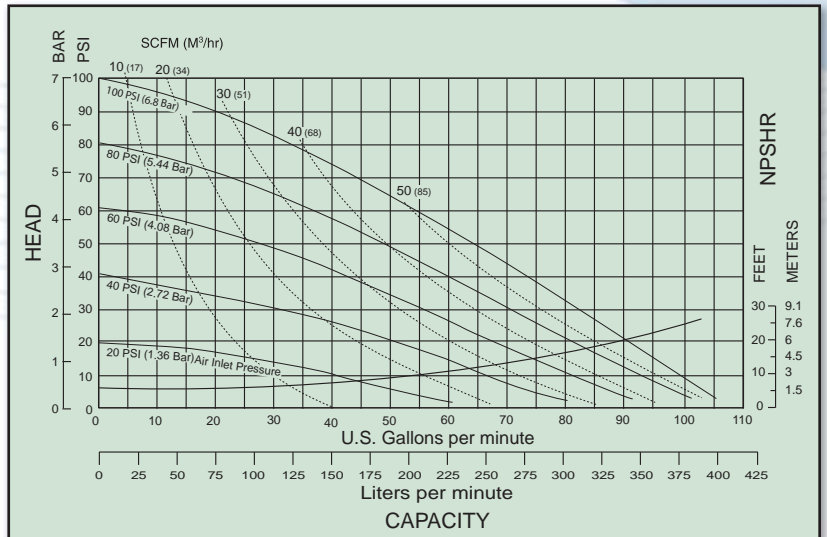

STANDARD DUTY

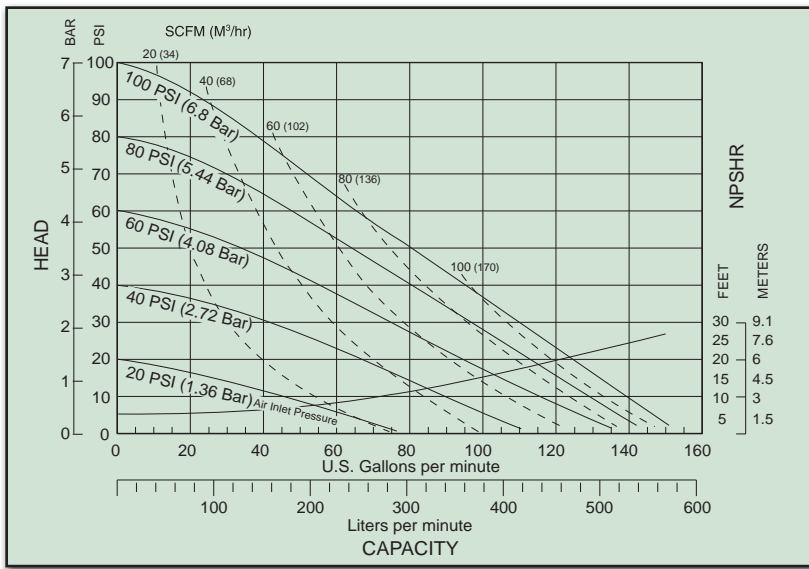

S20 Metallic Performance Curve



Permanently installed metallic standard duty pumps in an interior chemical industry sumping installation.

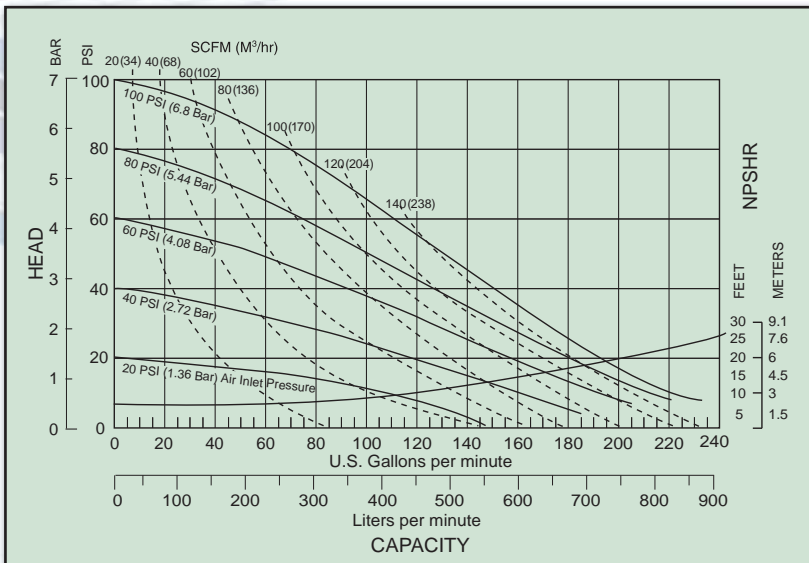

S30 Metallic Performance Curve

STANDARD DUTY

STANDARD DUTY BALL - NON-METALLIC

Standard Duty Non-Metallic Pumps are ideally suited for highly corrosive fluids, intermittent/on-demand, portable, low abrasive fluids, and suspended solids. Standard duty non-metallic pumps are constructed in Polypropylene, PVDF, Conductive Acetal and Conductive Polypropylene with TPE (thermal plastic elastomers) and PTFE options in diaphragms and check valves.

One-Piece Manifold
(NPT connections only)

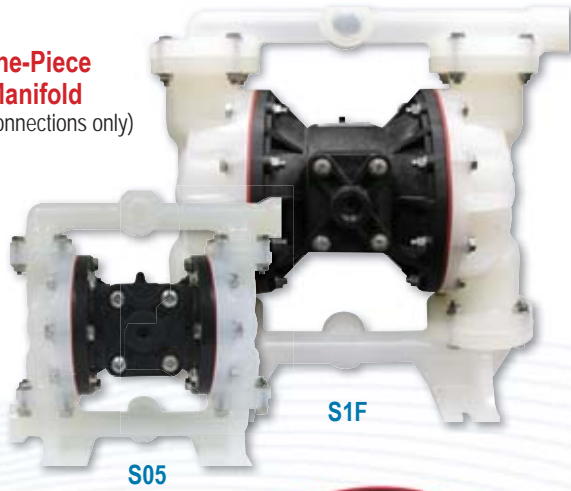

Polypropylene Center Sections

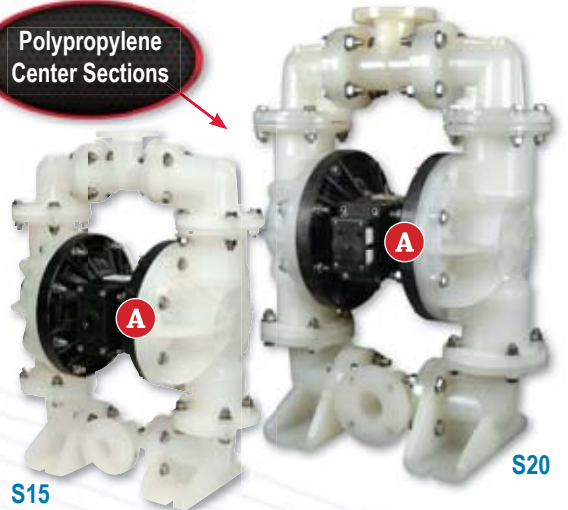

ATEX Conductive Polypropylene



ATEX Certified* Conductive PVDF

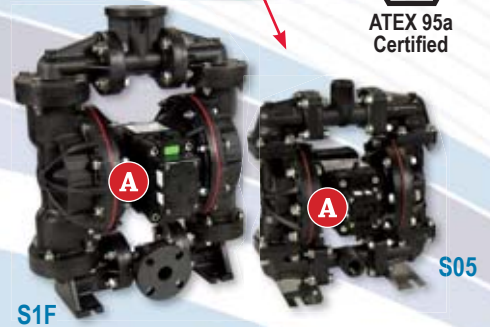

GLASS-filled center section

CARBON-filled wetted section

*ATEX 95a Compliance to EC Directive 94/9/EC for use of equipment in potentially explosive environments.

STANDARD DUTY

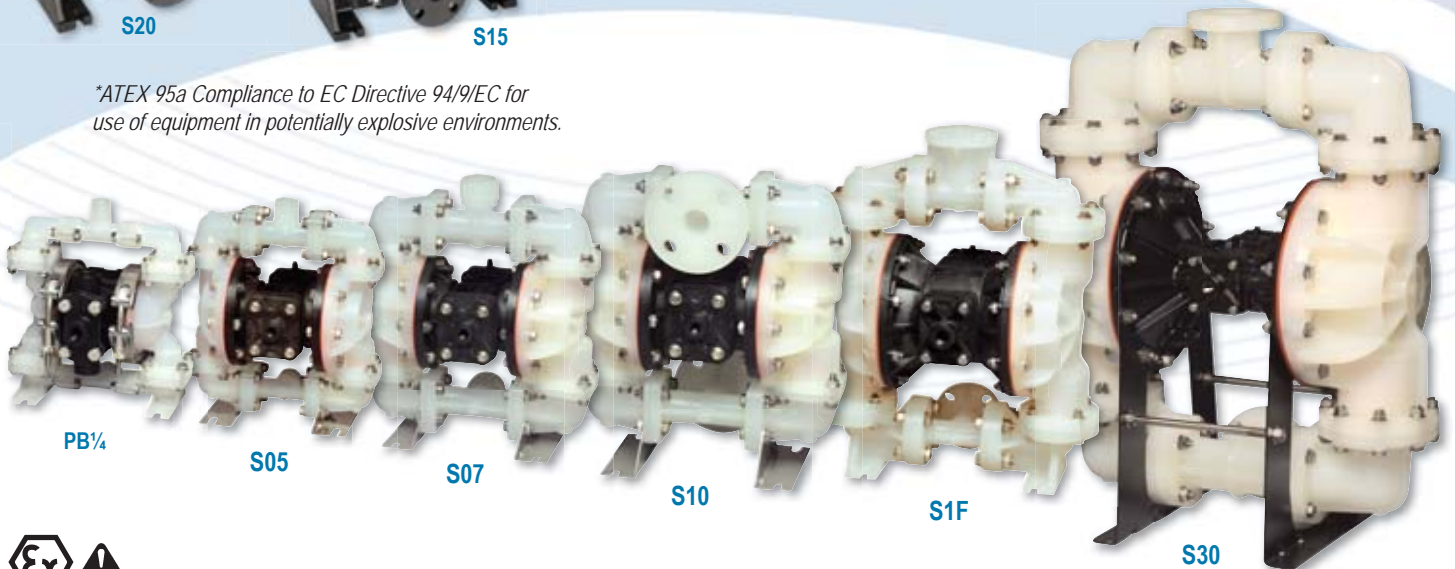

NOTE: Pumps are only ATEX Certified when ordered with wetted option C (Conductive Polypropylene) or wetted option V (Conductive PVDF), non-wetted option C (Conductive Polypropylene), pump options 6 or 7, and kit options 00, P1, A1, A2, A3 or A4. Applies to conductive plastic models.

DIMENSIONAL DETAIL



Distributor fabricated portable filtration cart with standard duty non-metallic pump.



Standard duty polypropylene pumps installed for chemical processing.

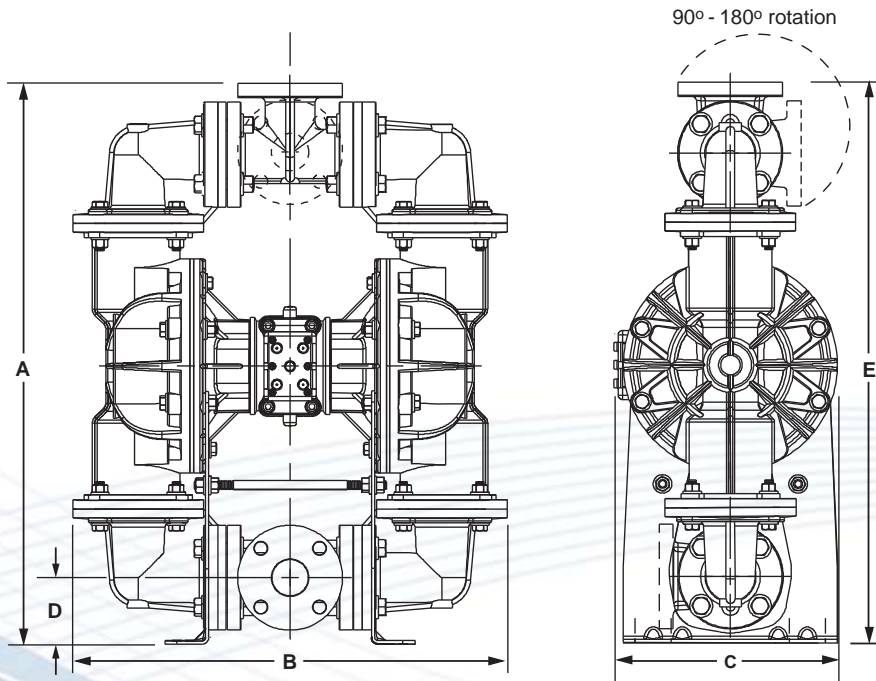

PUMP MODELS	A	B	C	E		Connection Style	Pipe Size	Displacement Per Stroke	Max Flow Per Minute	Max Solids Handling	Max Discharge Pressure
	Height	Width	Depth	Bottom of Base to Center Line of: Suction Discharge							
	inches (mm)	inches (mm)	inches (mm)	inches (mm)	inches (mm)						
PB¼	7 13/16 (198)	7 (178)	5 1/2 (140)	3/4 (19)	7 13/16 (198)	½" NPT	.25 (6)	.01 (.04)	4 (15)	.03 (1)	100 (6.9)
S05	11 5/16 (287)	10 1/8 (257)	7 1/16 (179)	1 3/8 (35)	11 5/16 (287)	1" NPT	.5 (13)	.026 (.098)	14 (52)	.125 (3)	100 (6.9)
S07T*	13 11/32 (339)	11 13/16 (300)	7 1/16 (179)	1 13/16 (46)	13 11/32 (339)	1½" NPT	.75 (20)	.016 (.059)	13 (48)	.38 (9)	100 (6.9)
S07	13 11/32 (339)	11 13/16 (300)	7 1/16 (179)	1 13/16 (46)	13 11/32 (339)	1½" NPT	.75 (20)	.026 (.098)	23 (87)	.15 (4)	100 (6.9)
S10	13 13/16 (351)	11 13/16 (300)	7 9/16 (192)	2 1/2 (64)	11 11/16 (297)	1" ANSI	1 (25)	.026 (.098)	23 (87)	.15 (4)	100 (6.9)
S1F	21 (533)	17 (433)	11 5/8 (295)	2 1/2 (64)	21 (533)	1" U	1 (25)	.19 (.72)	53 (200)	.25 (6)	100 (6.9)
S15	28 3/4 (730)	23 (584)	13 (330)	3 1/2 (89)	25 3/16 (640)	1½" ANSI or DIN	1.5 (40)	.36 (1.36)	100 (378)	.47 (12)	100 (6.9)
S20	32 1/4 (819)	23 13/16 (605)	13 (330)	3 13/16 (97)	28 3/16 (716)	2" U	2 (50)	.36 (1.36)	160 (605)	.66 (17)	100 (6.9)
S30	40 5/8 (1032)	33 3/8 (848)	18 1/4 (464)	4 7/8 (124)	40 5/8 (1032)	3" ANSI	3 (80)	.9 (3.41)	238 (901)	.71 (18)	100 (6.9)

All Dimensions +/- 1/8 (3) *T= Trihedral
U = Universal: Fits both ANSI or DIN

STANDARD DUTY

STANDARD DUTY BALL - NON METALLIC

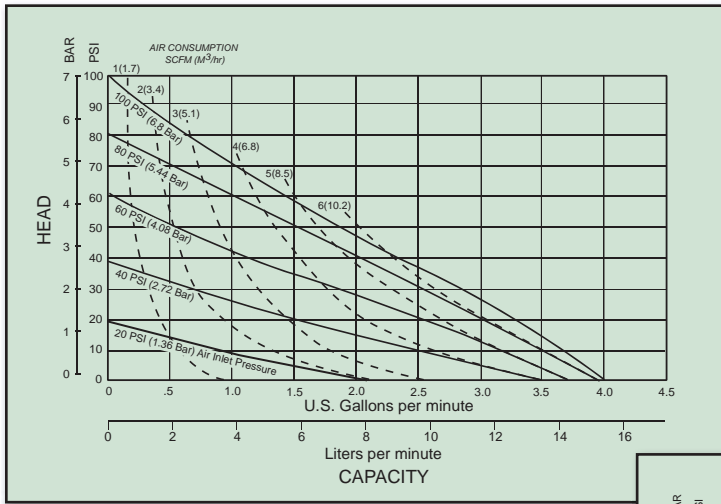

PB^{1/4} Non-Metallic Performance Curve

S05 Non-Metallic Performance Curve

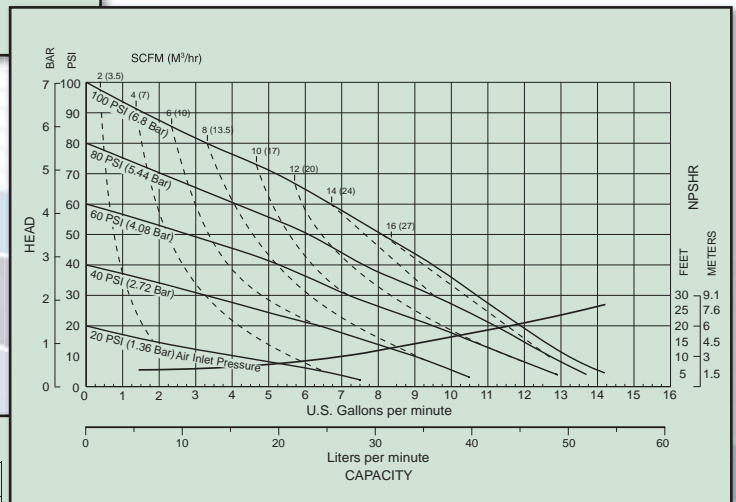

S07T Trihedral Non-Metallic Performance Curve

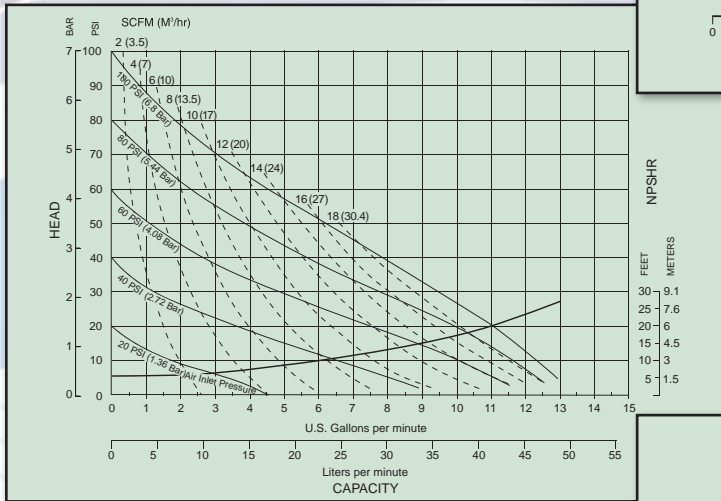

S07/S10 Non-Metallic Performance Curve

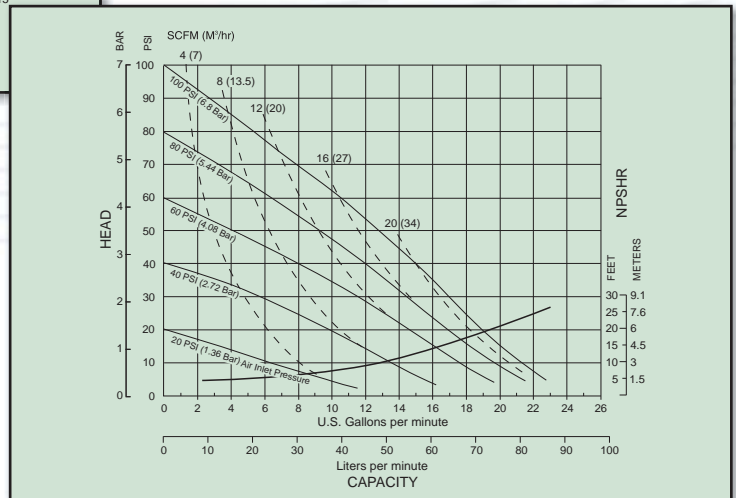

STANDARD DUTY

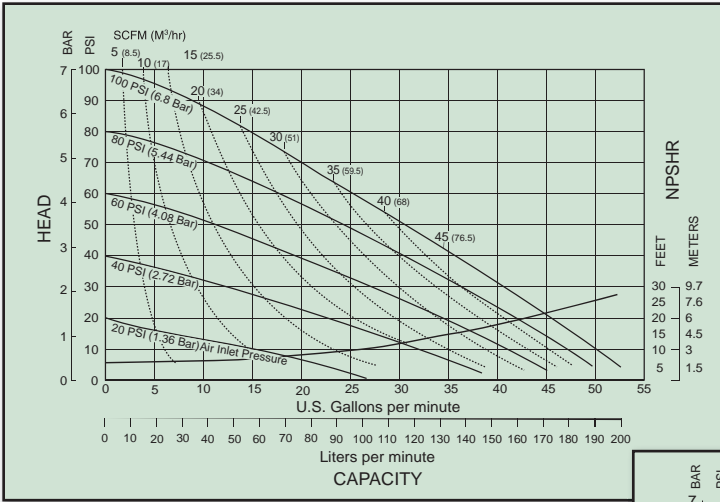

S1F Non-Metallic Performance Curve

S15 Non-Metallic Performance Curve

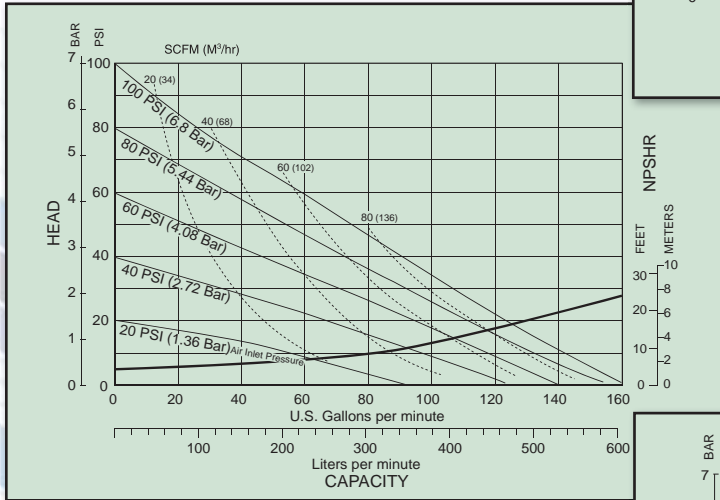
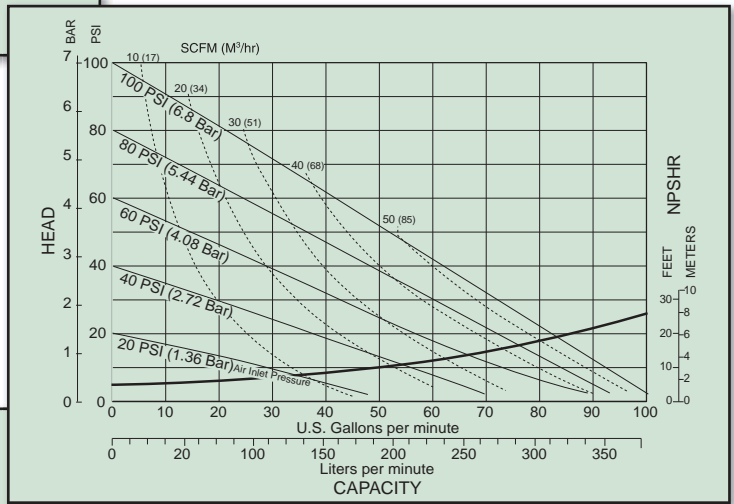

S30 Non-Metallic Performance Curve

S20 Non-Metallic Performance Curve

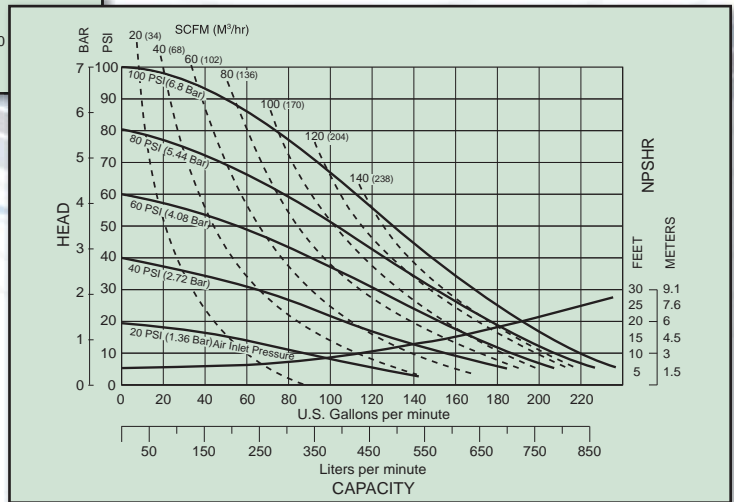

STANDARD DUTY

HIGH PRESSURE DUTY



SH2-M



EH2-M

Air-powered single diaphragm high pressure metallic pumps deliver discharge pressure twice the inlet pressure, up to 250 PSI (17 BAR). Designed for filter press feed and applications requiring higher discharge pressures. Available in Aluminum, Cast Iron and Stainless Steel with various elastomer options.

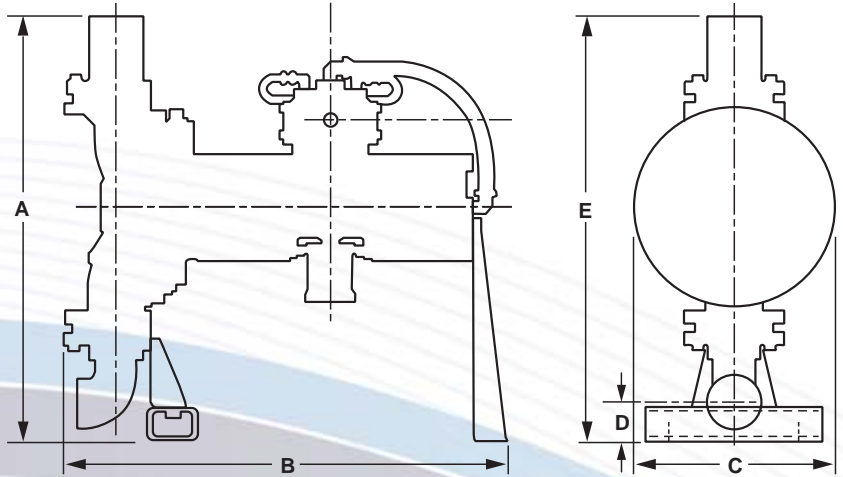

PUMP MODELS	A	B	C	D	E	Connection Style	Pipe Size	Displacement Per Stroke	Max Flow Per Minute	Max Solids Handling	Max Discharge Pressure
	Height	Width	Depth	Bottom of Base to Center Line of Suction	Bottom of Base to Center Line of Discharge		inch (mm)	gal (liter)	gal (liter)	inch (mm)	psi (bar)
	inches (mm)	inches (mm)	inches (mm)	inches (mm)	inches (mm)						
EH2-M	25 (635)	25 13/16 (656)	11 3/4 (298)	2 3/16 (56)	25 (635)	2" NPT	2 (50)	.30 (1.1)	62 (235)	.25 (6)	250 (17.2)
SH2-M	18 9/16 (471)	26 7/8 (683)	11 3/8 (289)	11 15/32 (291)	5 11/32 (136)	2" NPT	2 (50)	.30 (1.1)	62 (235)	2 (50)	250 (17.2)

All Dimensions +/- 1/8 (3)

EH2-M & SH2-M Performance Curve

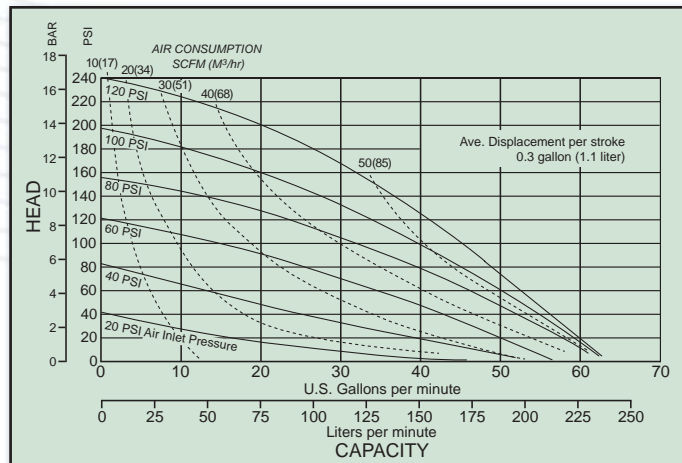

HIGH PRESSURE DUTY - BLAGDON

Blagdon 1" & 2" High Pressure Pumps provide enhanced power in applications where pressure is paramount and flow rate is an issue. Using two air chambers to double the air per stroke, these pumps achieve discharge pressure up to 238 pounds per square inch with flow rates as high as 30 gallons per minute for N25 and as high as 90 gallons per minute with N50.

The Blagdon HP Pump's full flow design incorporates an additional air chamber to deliver higher flow rates with less pulsation, so there's less wear on pipes and fittings. In addition, the pump can start at zero head pressure with no damage to diaphragms and no need for a separate fill pump.

The pumps are available in either aluminum or stainless steel. It features a non-stalling, non-icing air valve system with shoe-valve technology to eliminate blow-by.

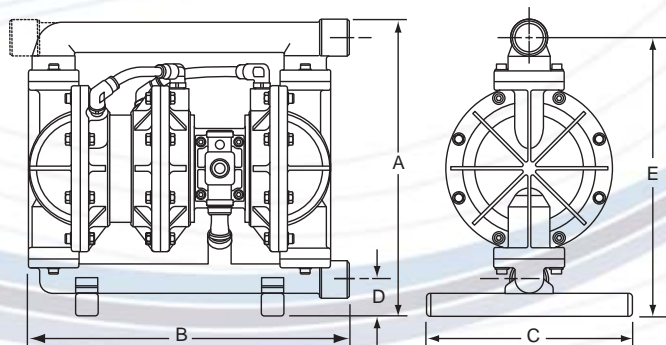
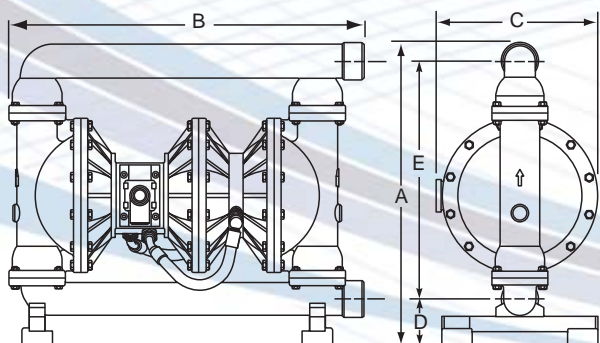
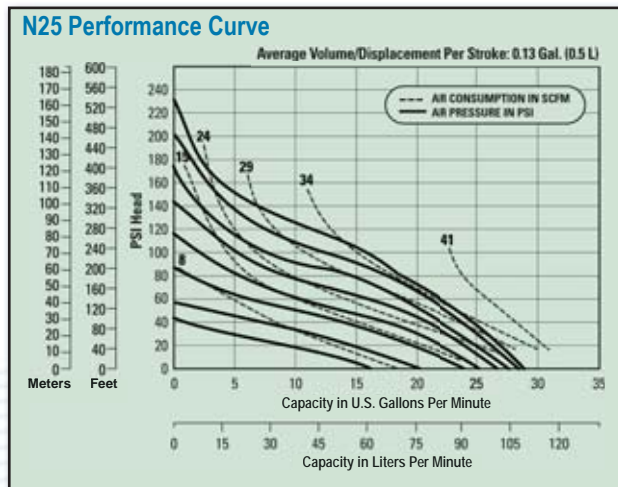
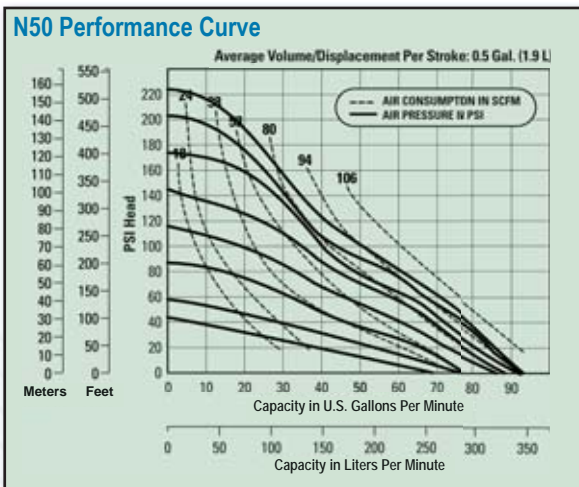
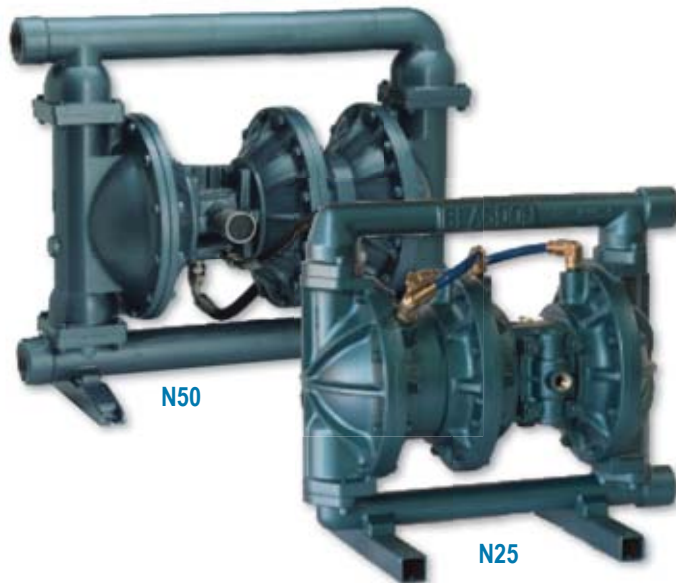

PUMP MODELS	A	B	C	D	E	Connection Style	Pipe Size	Displacement Per Stroke	Max Flow Per Minute	Max Solids Handling	Max Discharge Pressure
	Height	Width	Depth	Bottom of Base to Center Line of Suction	Center Line of Discharge						
	inches (mm)	inches (mm)	inches (mm)	inches (mm)	inches (mm)						
N50	24.41 (620)	28.70 (729)	13.07 (332)	3.66 (93)	22.95 (583)	1" NPT	2 (50)	.5 (1.9)	90 (341)	.125 (3)	238 (16)
N25	15.94 (405)	18.27 (464)	11.02 (280)	1.97 (50)	14.95 (380)	1" NPT	1 (25)	.13 (.5)	30 (114)	.125 (3)	238 (16)

All Dimensions +/- 1/8 (3)

FILTER PRESS SYSTEMS

Built-to-order, multi-pump systems combine a high volume fill pump with a high pressure feed pump. Frequently used for filter press feed applications, the systems produce operating pressures to 250 PSI (17 BAR). This results in shortened press cycles, drier cake and less costly disposal.

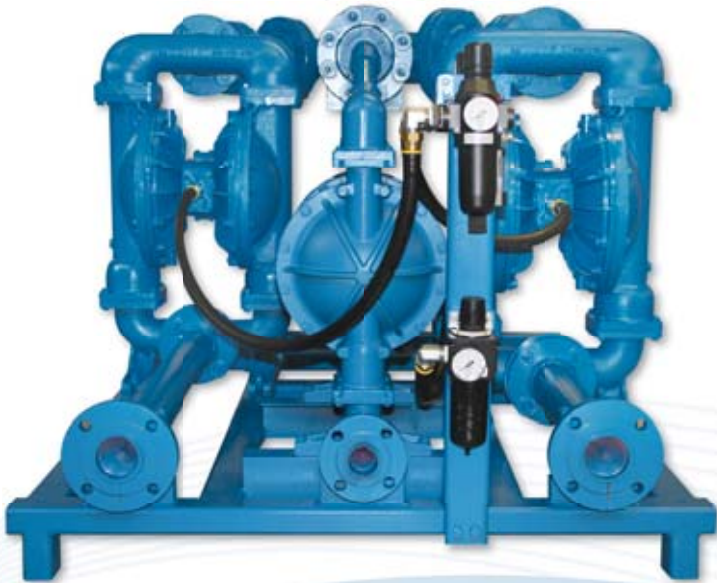
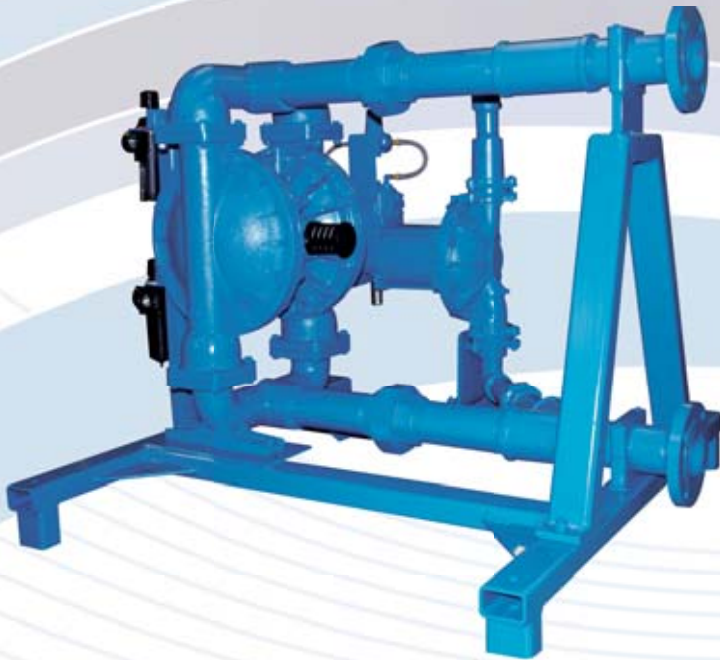

Plate and frame filter press pumping system



Custom built heavy duty wastewater, filter press pumping system

BASE SYSTEMS

040.010.000. consists of:

- (1) S20W1INCANS100.
- (1) EH2-M, TN-4-I
- Filter/Regulator (1) 020.052.000.
- Filter/Regulator (1) 020.051.000.

Includes base & piping with 2" flange suction & discharge connections.

040.011.000. consists of:

- (1) S30W1INCANS100.
- (1) EH2-M, TN-4-I
- Filter/Regulator (1) 020.052.000.
- Filter/Regulator (1) 020.051.000.

Includes base & piping with 3" flange suction & discharge connections.

040.003.000. consists of:

- (1) SA2-A, DA-5-II
- (1) SH2-M, DN-7-I
- Filter/Regulator (1) 020.052.000.
- Filter/Regulator (1) 020.051.000.

Includes base & piping with 2" flange suction & discharge connections.

040.004.000. consists of:

- (1) SA3-M, DA-2-II
- (1) SH2-M, DN-7-I
- Filter/Regulator (1) 020.052.000.
- Filter/Regulator (1) 020.051.000.

Includes base & piping with 3" flange suction & discharge connections.

PLEASE CONSULT FACTORY FOR:

- LEAD TIME
- PRICING
- COMBINATIONS OF PUMPS FOR OTHER SYSTEMS

NON-CLOG WASTEWATER PUMPS

Non-Clog Wastewater Pumps are fitted with swing check valves and easy access clean-outs. The pumps are designed specifically for slurry and solids-laden materials. Flap valves allow passage of suspended, pipe-size solids and stringy material. Constructed of cast iron and durable epoxy coating inside and out.

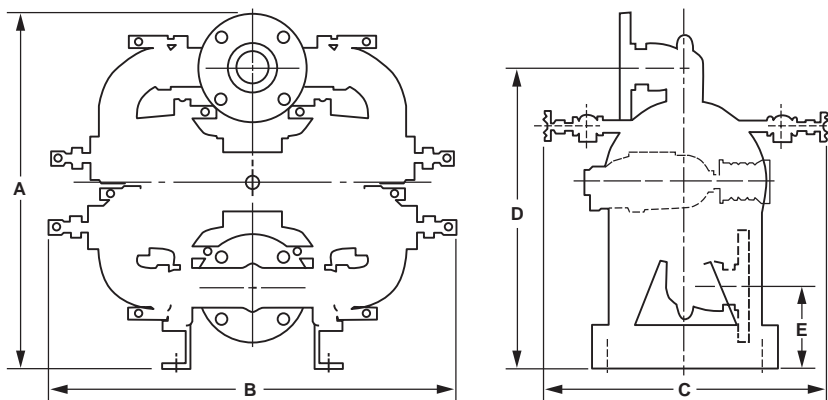

W15

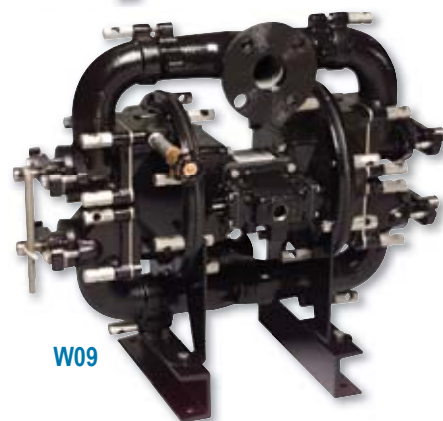

W09

PUMP MODELS	A	B	C	D		Connection Style	Pipe Size	Displacement Per Stroke	Max Flow Per Minute	Max Solids Handling	Max Discharge Pressure
	Height	Width	Depth	Bottom of Base to Center Line of:							
	inches (mm)	inches (mm)	inches (mm)	Suction	Discharge						
	inches (mm)	inches (mm)	inches (mm)	inches (mm)	inches (mm)	inch (mm)	gal (liter)	gal (liter)	inch (mm)	psi (bar)	
W09-2	23 3/4 (608)	28 1/4 (724)	19 3/4 (506)	20 3/4 (531)	5 5/8 (144)	2" 125# ANSI	2 (50)	.43 (1.60)	140 (530)	2 (50)	125 (8.6)
W09-3	24 1/2 (627)	28 1/4 (724)	19 3/4 (506)	20 3/4 (531)	5 5/8 (144)	3" 125# ANSI	3 (80)	.43 (1.60)	140 (530)	2 (50)	125 (8.6)
W15-3	31 1/2 (800)	44 1/2 (1130)	21 1/2 (546)	27 3/4 (705)	6 (152)	3" 125# ANSI	3 (80)	1.23 (4.66)	260 (988)	3 (76)	125 (8.6)
W15-4	32 1/4 (819)	44 1/2 (1130)	21 1/2 (546)	27 3/4 (705)	6 (152)	4" 125# ANSI	4 (100)	1.23 (4.66)	260 (988)	3 (76)	125 (8.6)

All Dimensions +/- 1/8 (3)

W09 Performance Curve

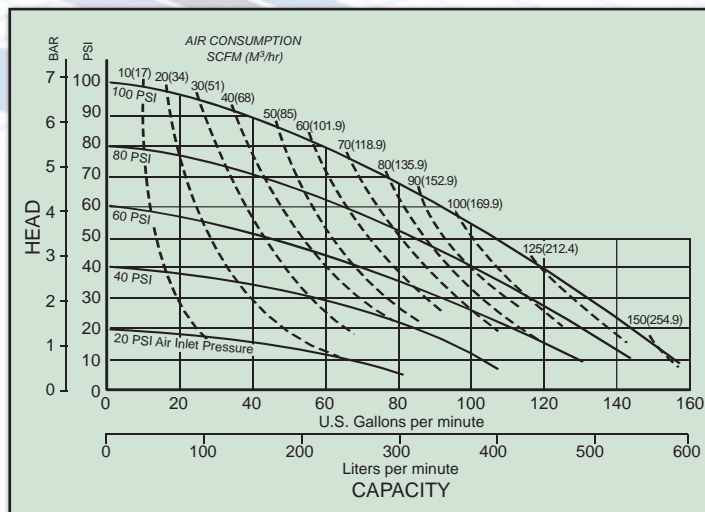

W15 Performance Curve

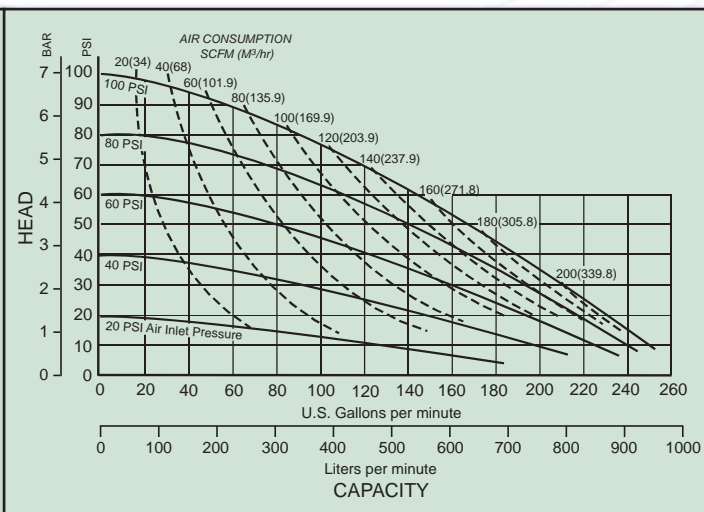

SPECIAL DUTY - UL PUMP

UL: Underwriters Laboratory



U1F

UL (Underwriters Laboratory) Pumps are designed to meet UL79 standards for diaphragm pumps handling flammable liquids. All Aluminum construction with approved Nitrile or Virgin PTFE UL elastomers. Fully groundable to prevent static discharge.

U1F Performance Curve

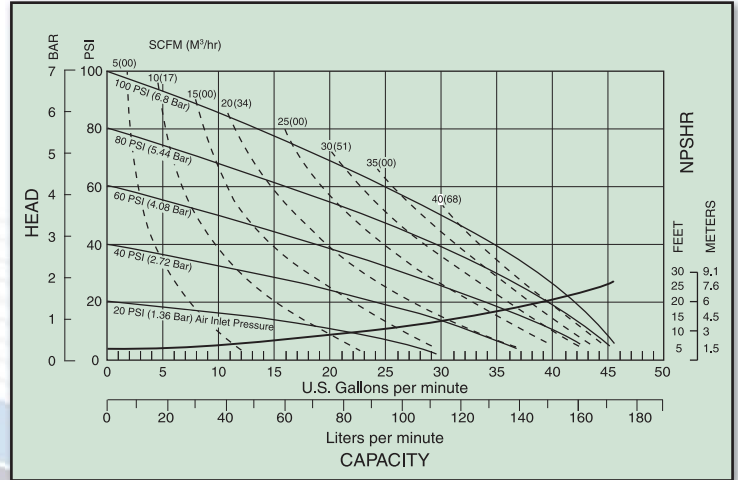

Underwriters
Laboratory

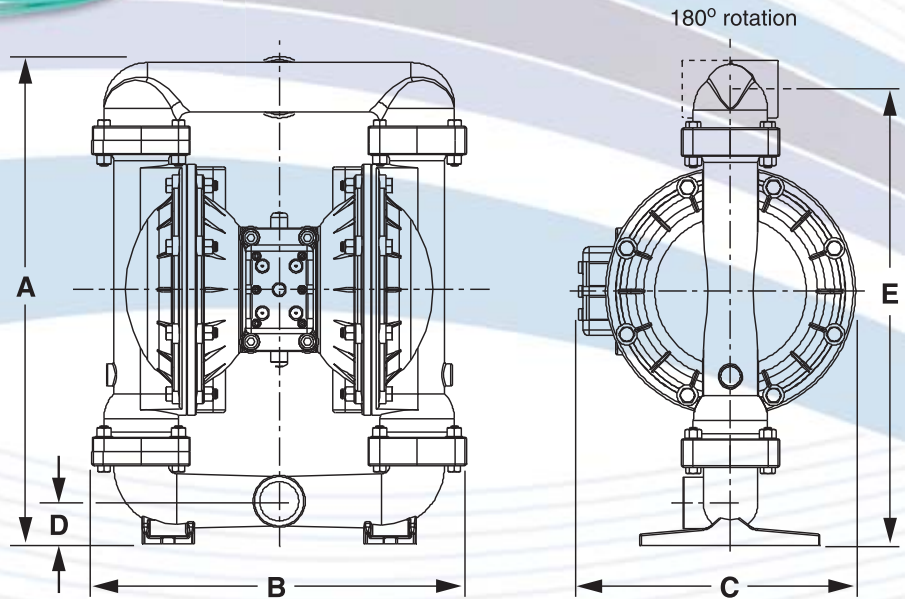

PUMP MODELS	A	B	C	D		Connection Style	Pipe Size	Displacement Per Stroke	Max Flow Per Minute	Max Solids Handling	Max Discharge Pressure
	Height	Width	Depth	Bottom of Base to Center Line of: Suction Discharge							
	inches (mm)	inches (mm)	inches (mm)	inches (mm)	inches (mm)						
U1F	12 23/32 (323)	10 1/4 (260)	10 3/8 (264)	1 3/32 (28)	11 27/32 (301)	1" NPT	1 (25)	.11 (.42)	45 (170)	.25 (6)	125 (8.6)

All Dimensions +/- 1/8 (3)

DEWATERING DUTY - SUBMERSIBLES



**PortaPump®
SPA1 1/2-E**

The **PortaPump® Submersible, Battery-Powered Pump** operates using any 12-volt car or truck battery. It comes equipped with cables and battery clips. Extremely portable, the pump weighs only 33 pounds (15kg) and can fit through openings as small as 10" (25cm). Electrically safe and whisper quiet.

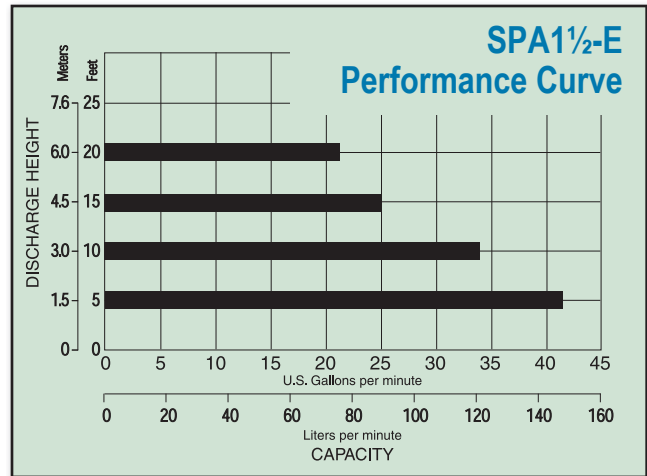

PUMP MODELS	Pipe Size	Max Flow Per Minute	Max Solids Handling	Max Discharge Height
	Inches (mm)	gal (liters)	Inches (mm)	feet (m)
SPA11/2-E3	1.5 (40)	43 (163)	1/16 (1)	25 (7.6)
SMA3-A	3 (80)	300 (1140)	1.5 (40)	65 (19.8)

The **SludgeMaster™ Submersible, Air-Powered Trash Pump** handles mud, leaves, twigs, sand, sludge, trash-laden water and soft solids to 1 1/2" (3.8cm). High capacity, low head. The pump weighs only 59 pounds (26kg), and can fit through an opening as small as 14" (35cm). Sturdy construction for rough handling and long life. Optional rock screen available.

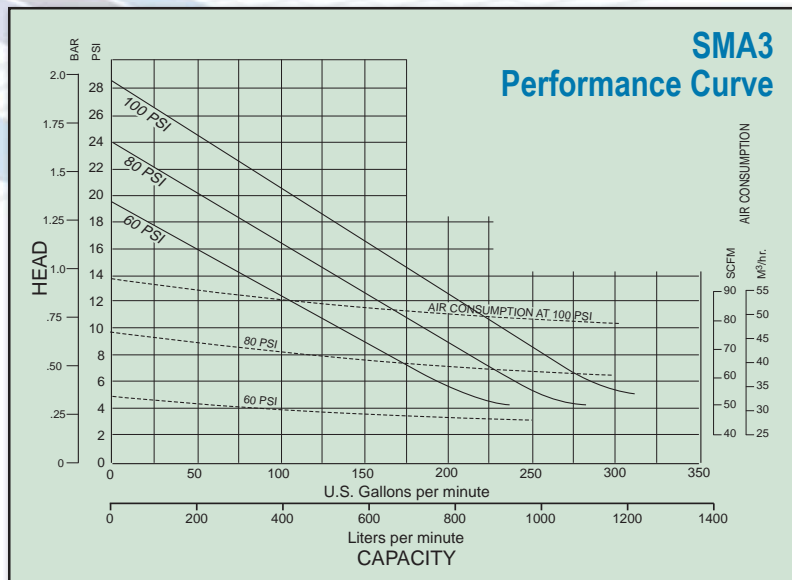

**SludgeMaster™
SMA3**



SPECIAL DUTY - USDA PUMPS

USDA: United States Department of Agriculture

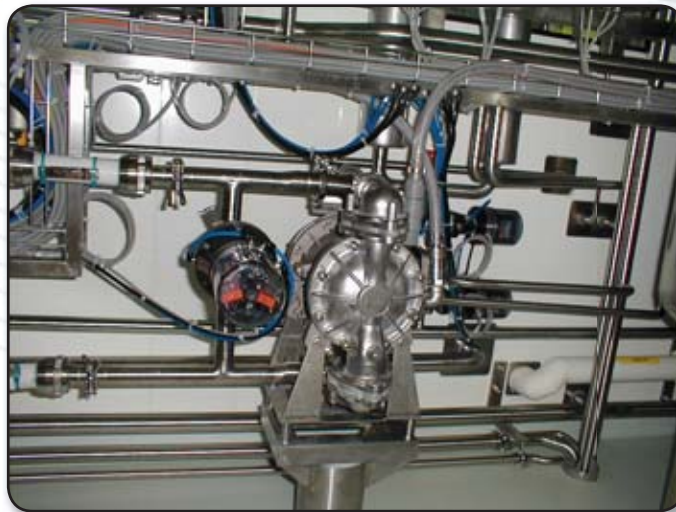
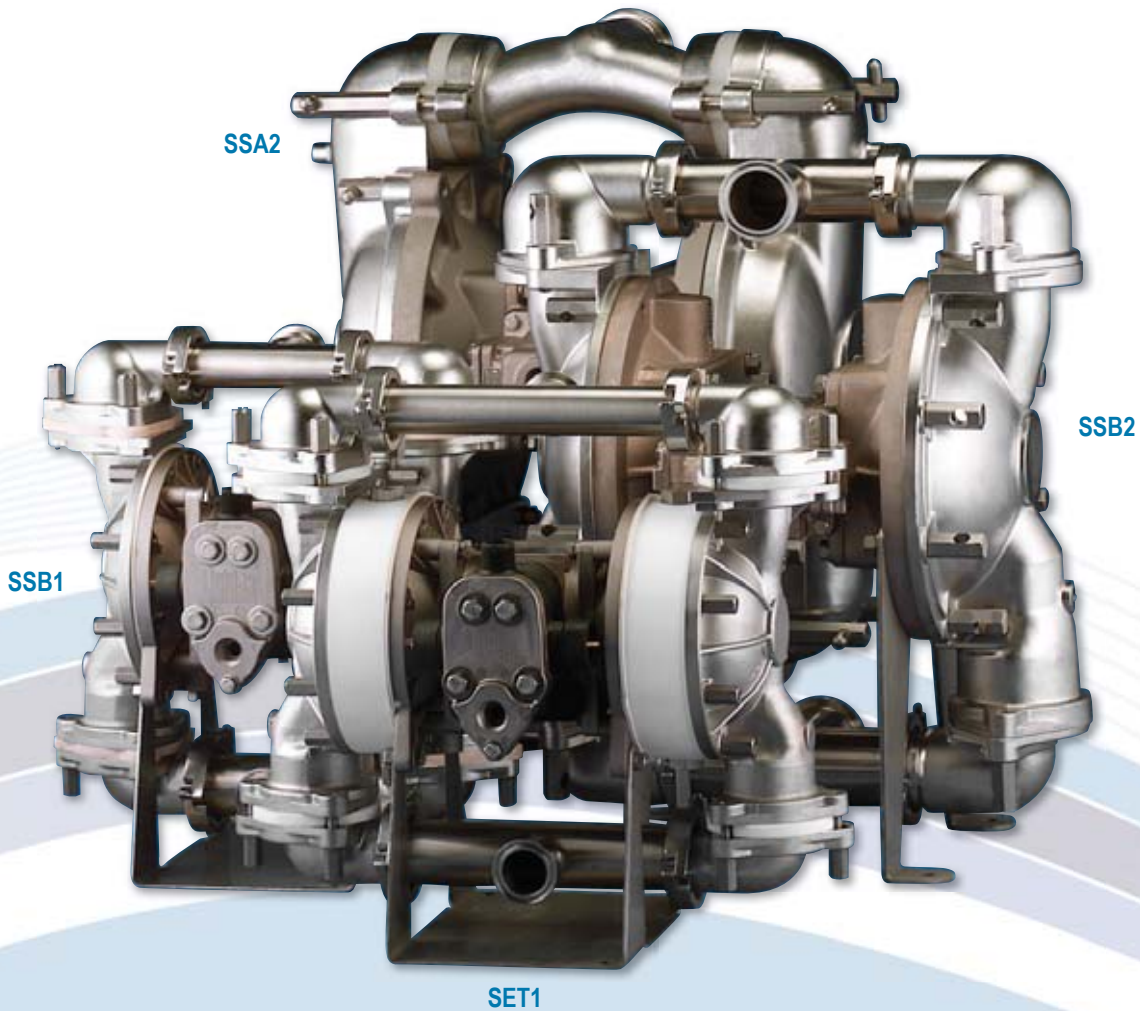

USDA certified ball check valve pump in a clean-in-place, sanitary piping installation.

DSB1 Designed to meet USDA (Dairy Division) Standards. Must be fitted with Electronic Leak Detector to maintain Dairy Approval. Leak Detector purchased separately.

SSB1 Designed to meet USDA Standards. 1 1/2" (38mm) Ball Valve, 0 to 54 GPM (204 liters) Handles solids to 1/4" (6mm), Top Discharge

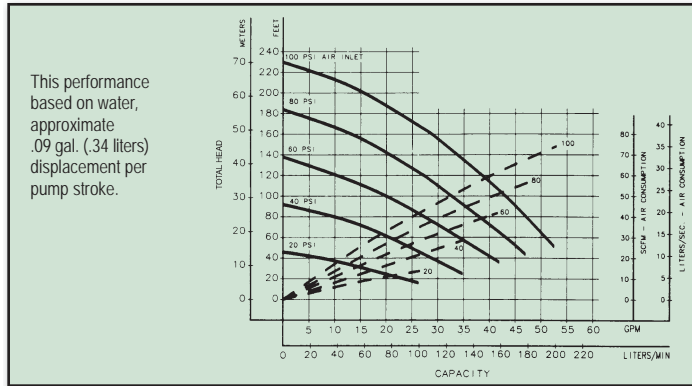

SSB2 Designed to meet USDA Standards. 2" (50.8mm) Ball Valve, 0 to 125 GPM (473 liters) Handles solids to 1/4" (6mm), Top Discharge

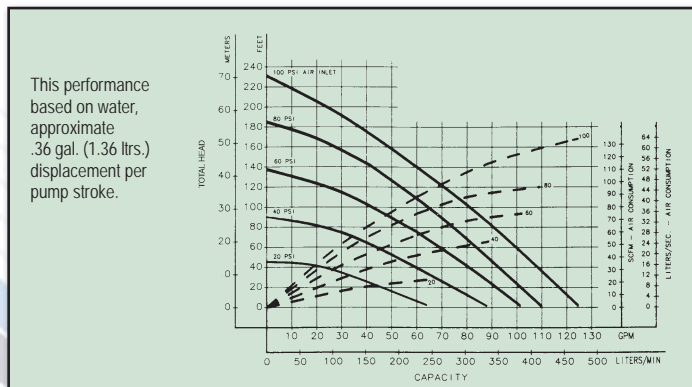

SSA2 Designed to meet USDA Standards. 2 1/2" (63.5mm) Flap Valve, 0 to 150 GPM (570 liters) Handles solids to 1 1/16" (27.4mm), Top or Bottom Discharge

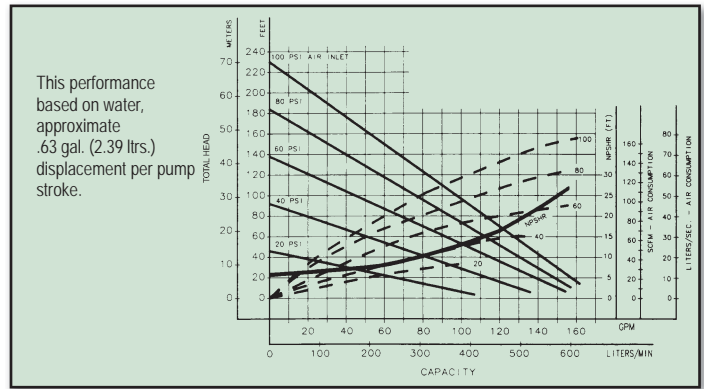

SET1 Sanitary Pump designed to meet USDA Standards. 1" (25.4mm) Ball Valve, 0 to 54 GPM (204 liters) Handles solids to 1/4" (6mm), Top Discharge

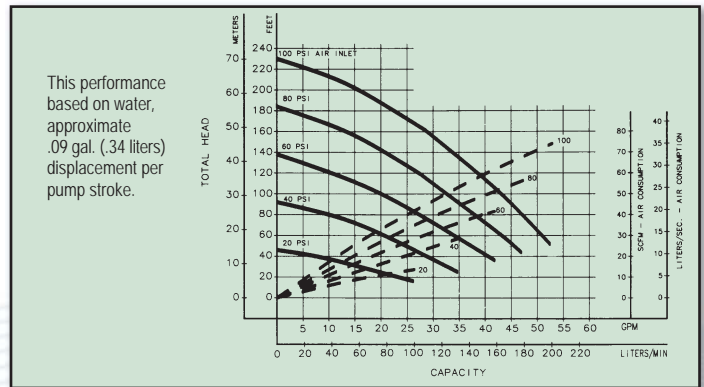

SET2 Sanitary Pump designed to meet USDA Standards. 2" (50.8mm) Ball Valve, 0 to 123 GPM (465 liters) Handles solids to 1/4" (6mm), Top Discharge

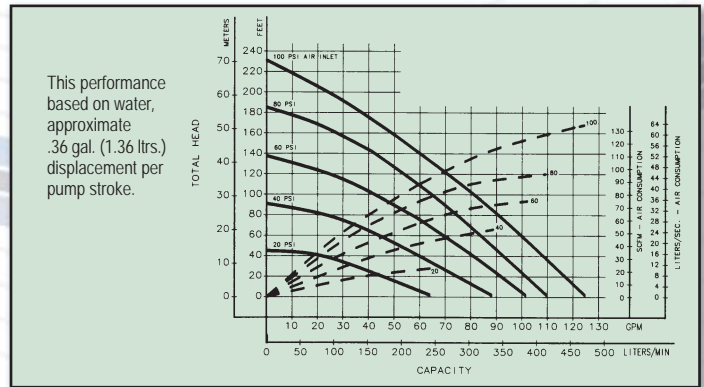

Electronic Leak Detector - This leak detector works on the principle of conductance, sensing liquid or condensation entering the air side of the pump. It is installed through a boss on the inner chambers. A probe senses pooled conductive liquid, producing a low current (1.2 volt DC), which signals a control unit. Indicator lights signal not only contamination, but also which side is tainted. The control unit can be easily wired to an audible alarm or pump shutdown mechanism if needed. Modular, water-tight construction.

Sensitivity range is adjustable from 500 ohm (2000 micro mho) to 100,000 ohm (10 micro mho). Available for 115V (032.017.000) and 220V (032.018.000) power supply. **This unit must be purchased separately.**

Materials of Construction - Wetted parts of these Meat/Poultry* pumps are electropolished 316 and 302/304 Stainless Steel. Non-wetted parts are electroless nickel-plated aluminum and polypropylene. All are fitted with food grade, white nitrile elastomers. The Dairy* pumps have mechanically-polished 316 Stainless Steel wetted parts, and must be fitted with the SANDPIPER Electronic Leak Detector to maintain Dairy standards.

*Designed to meet USDA Standards.

Note: The Electronic Leak Detector must be purchased separately.

SPECIAL DUTY - FDA COMPLIANT PUMPS

FDA: Food & Drug Administration

FDA Material Compliant Pumps

are ideally suited for a variety of food processing, pharmaceutical and cosmetic industry applications. The pumps are available in 1" through 3" ball check valve designs and a 2" (line size solids handling) flap check valve design. Variable flow capacities across the range are 0-235 gallons per minute. These special duty pumps are constructed of FDA material compliant components of Stainless Steel (wetted castings) and a selection of FDA Santoprene, FDA Nitrile and PTFE diaphragms, check valves and valve seats. Standard non-wetted components are white epoxy coated Aluminum with stainless steel hardware. 1", 1½" and 2" pumps are offered with sanitary clamp fittings and 3" pumps are offered with an ANSI flange.

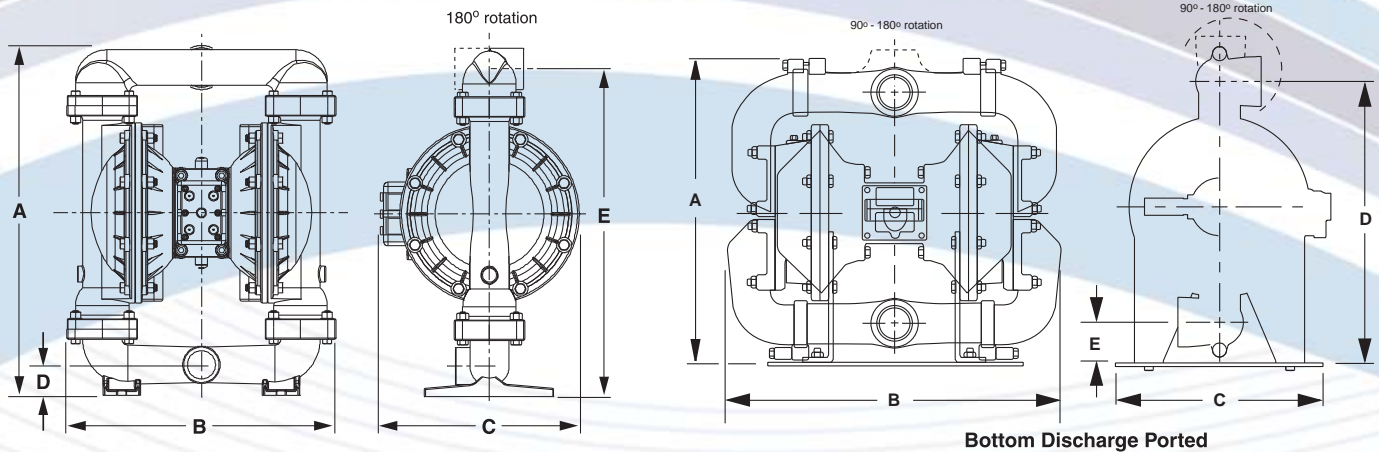
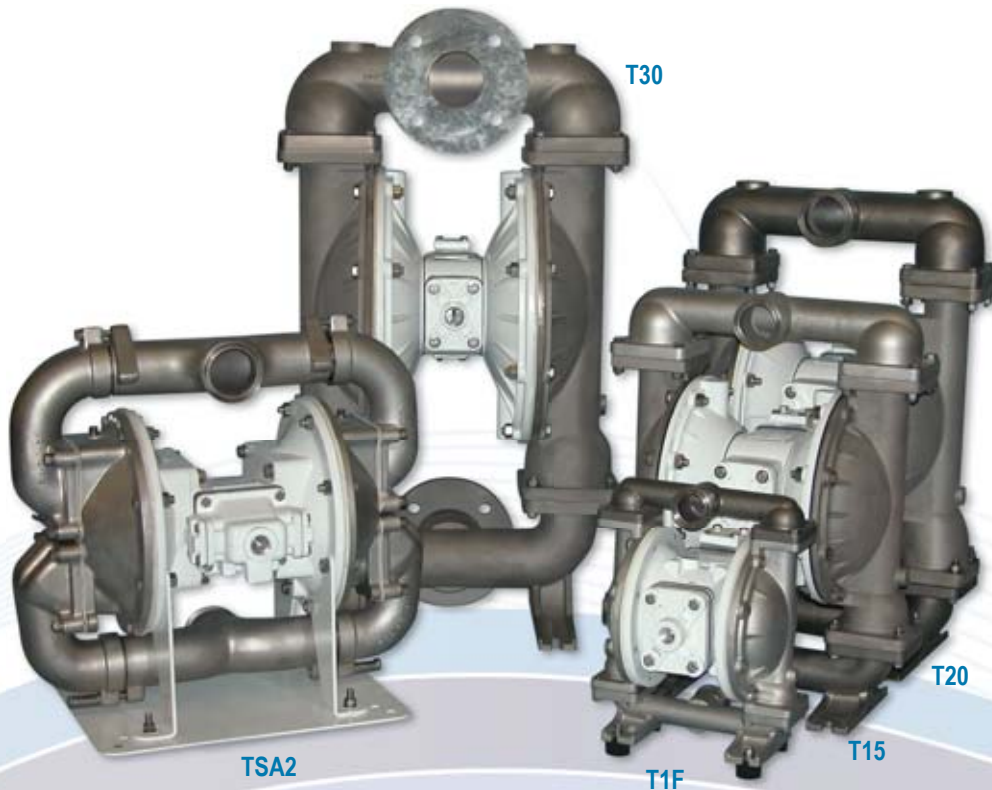

PUMP MODELS	A	B	C	D	E	Connection Style Sanitary Clamp	Pipe Size	Displacement Per Stroke	Max Flow Per Minute	Max Solids Handling	Max Discharge Pressure
	Height	Width	Depth	Bottom of Base to Center Line of:							
	inches (mm)	inches (mm)	inches (mm)	Suction	Discharge						
	inches (mm)	inches (mm)	inches (mm)	inches (mm)	inches (mm)		inch (mm)	gal (liter)	gal (liter)	inch (mm)	psi (bar)
TSA2	20 13/16 (529)	21 1/4 (539)	13 (330)	2 9/16 (55)	17 9/16 (447)	2½" Clamp	2 (50)	.43 (1.60)	140 (530)	2 (50)	125 (8.6)
T1F	12 31/32 (326)	10 1/4 (260)	10 3/8 (264)	1 7/32 (31)	11 31/32 (304)	1½" Clamp	1 (25)	.11 (.42)	45 (170)	.25 (6)	125 (8.6)
T15	21 13/16 (554)	16 21/32 (423)	12 23/64 (314)	1 31/32 (50)	20 3/8 (518)	2" Clamp	1.5 (40)	.41 (1.55)	106 (401)	.25 (6)	125 (8.6)
T20	26 9/16 (674)	16 7/8 (428)	12 19/32 (320)	2 (51)	24 3/4 (629)	2½" Clamp	2 (50)	.42 (1.59)	150 (567)	.25 (6)	125 (8.6)
T30	32 9/32 (820)	19 21/32 (499)	15 3/4 (400)	4 7/32 (107)	30 27/32 (808)	3" # FF ANSI	3 (80)	.94 (3.56)	238 (901)	.38 (9.5)	125 (8.6)

All Dimensions +/- 1/8 (3)

TSA2 Performance Curve

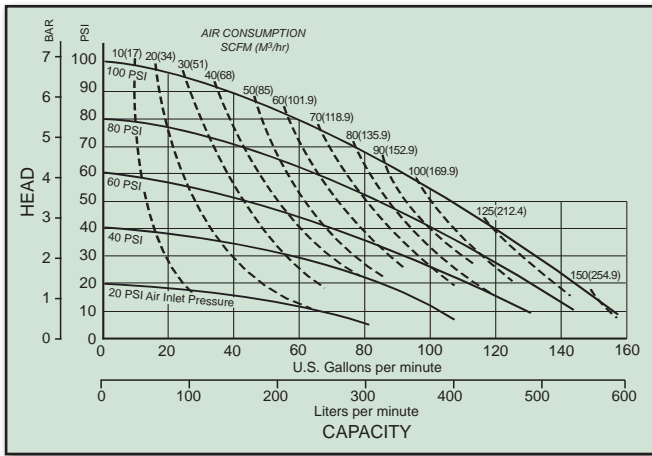

T1F Performance Curve

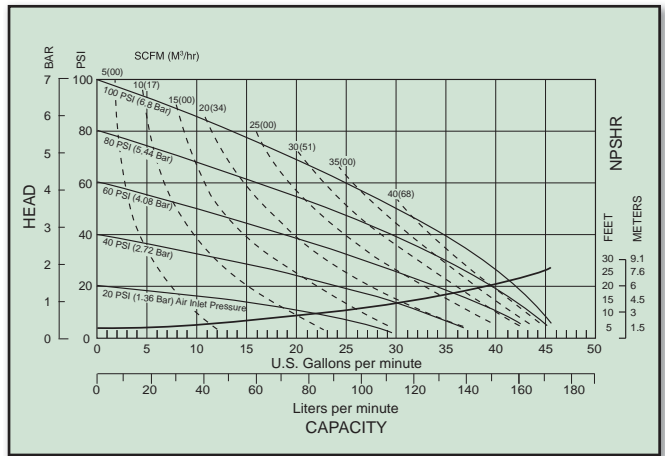

T15 Performance Curve

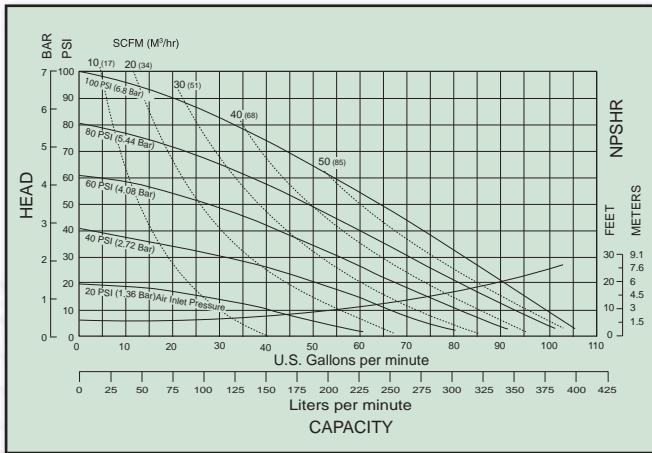

T20 Performance Curve

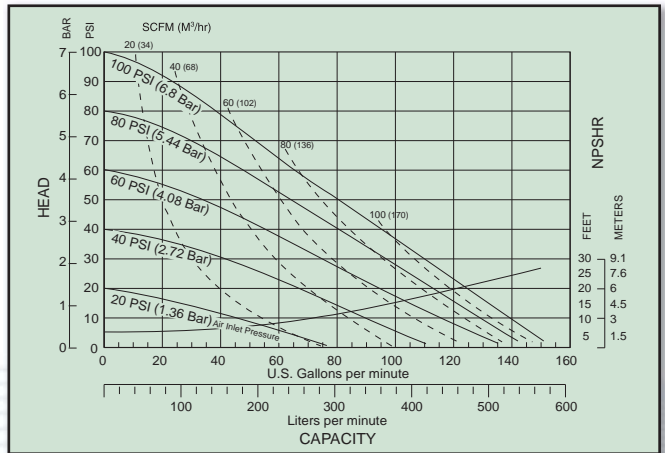

T30 Performance Curve

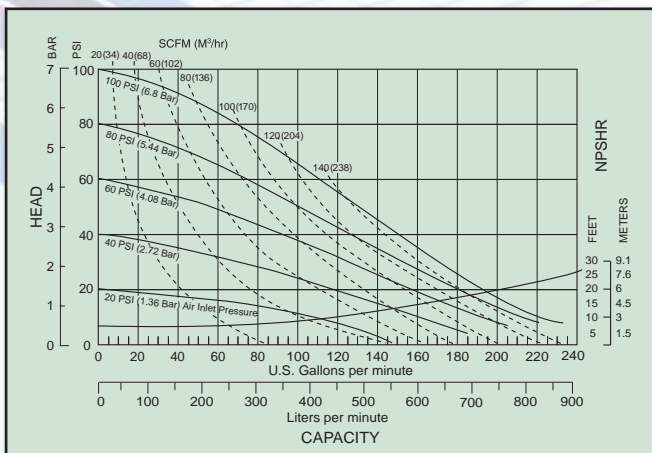

T30 FDA Material Certified pump cart system for wine industry applications.

SPECIAL DUTY - MINE/CONSTRUCTION



Part #475.246.000. Center Section
+ #475.248.000 = MSB2-A with Strainer Base

Also available Model MSB2-B
with Manifold Mounting Feet #475.249.000

Handle Mounted Standard Duty



S30XXXXXXXXHXXX

S20XXXXXXXXHXXX

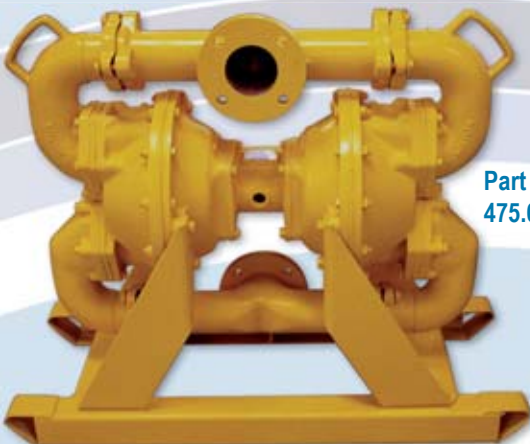

Part #
475.040.000

Skid Mounted SA3-C

Consult factory for skid
base dimensions.

Suction Stub
and Strainer

Part #
475.039.000



Consult factory for
suction tube dimensions.

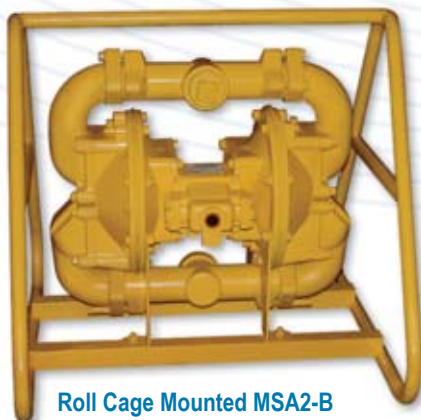

Roll Cage Mounted MSA2-B

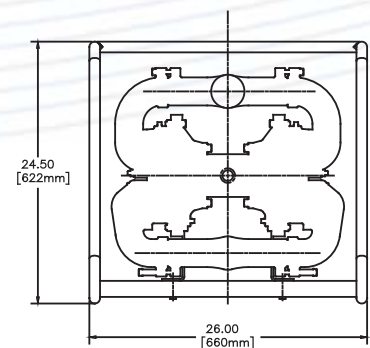
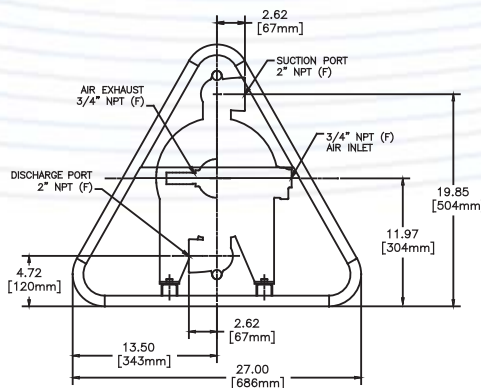

MSB2 Performance Curve

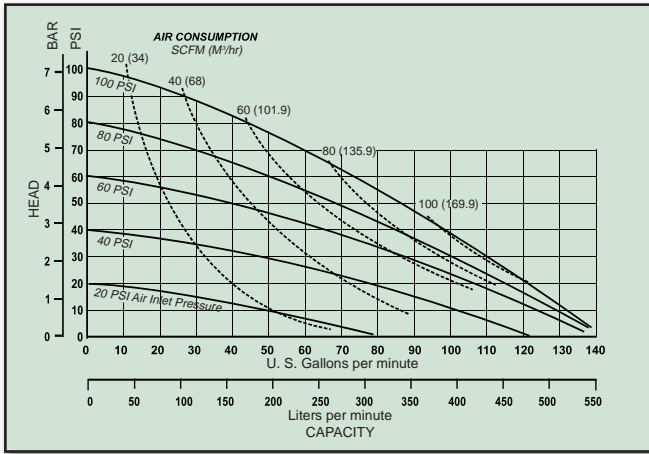

MSA2/MSA2-B/SA2-C Performance Curve

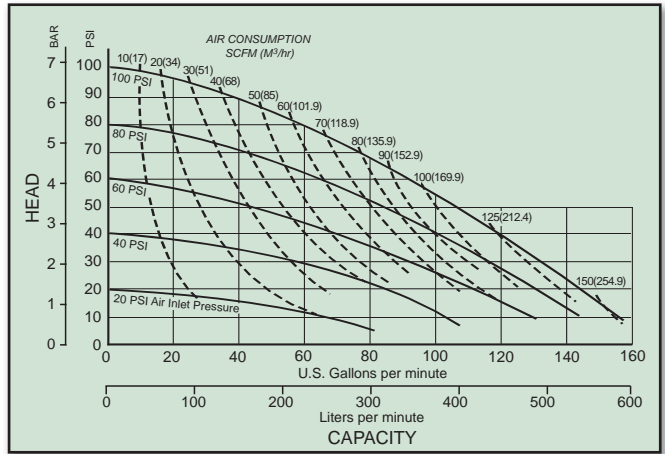

SA3-C Performance Curve

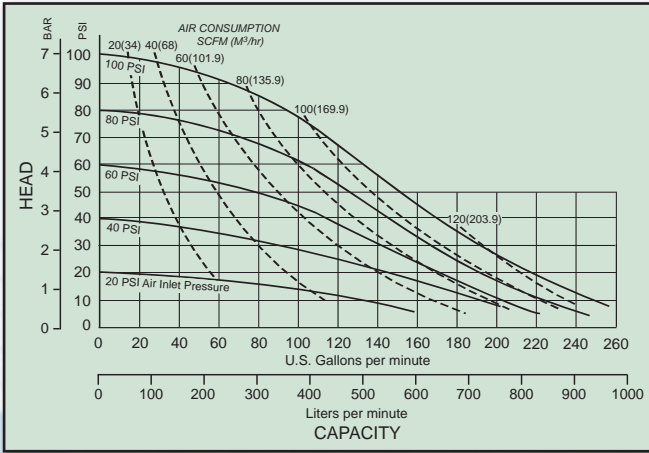

S20 Performance Curve

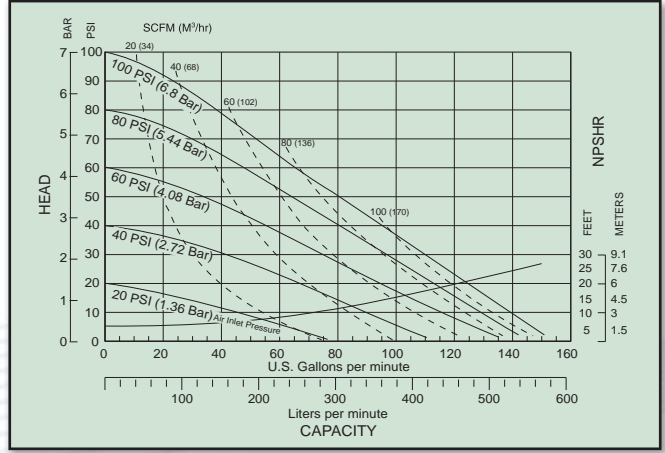

S30 Performance Curve

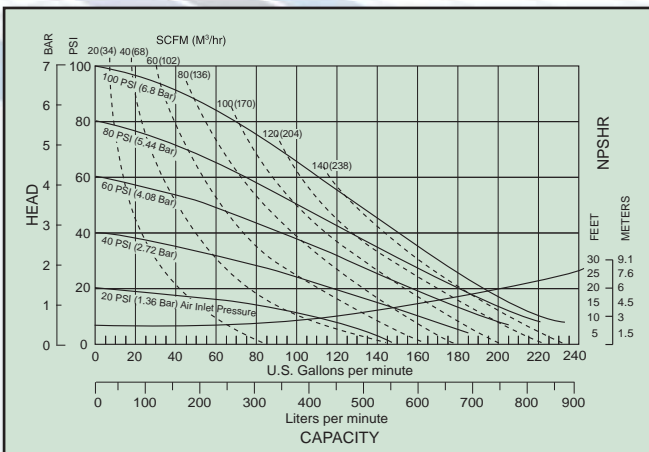

SPECIAL DUTY BALL - NATURAL GAS

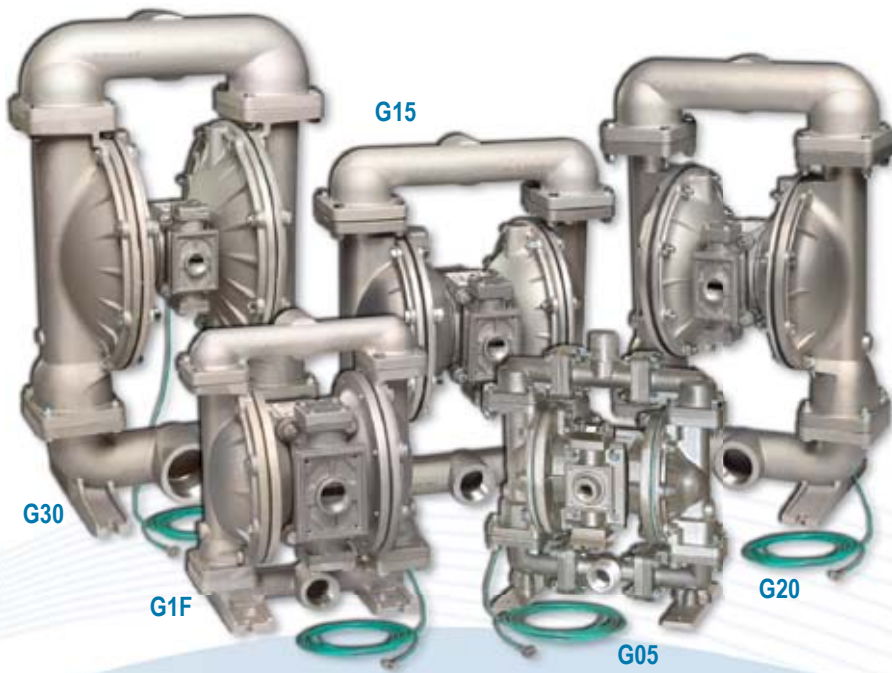

Burst Pressure to:
400 PSI (27.6 bar)

Temperature Limits:
-10°F (-23°C) to +180 °F (82°C)

These stringent tests meet the actual minimum and maximum temperatures that pumps are subjected to in typical gas and oil field applications.



Technical
 Letter No. 14



ANSI LC6

Natural Gas Operated Pumps are CSA* (Canadian Standards Association) certified to ANSI LC6 standard for operation using sweet or sour natural gas. The pumps are also compliant with NACE Standard MR0175/ISO15156. The gas pump utilizes Aluminum or 316 Stainless Steel wetted construction with Nitrile or Virgin PTFE diaphragms and check balls. The gas valve is constructed of Aluminum with Nitrile or FKM (fluorocarbon) elastomers. Pumps are fully groundable, preventing static discharge. A Stainless Steel gas valve option is available on G15 to G30 pumps for more corrosive applications.

*CSA is the Canadian Standards Association, an international organization for testing products to ensure public safety, and the governing agency for the Natural Gas Industry.

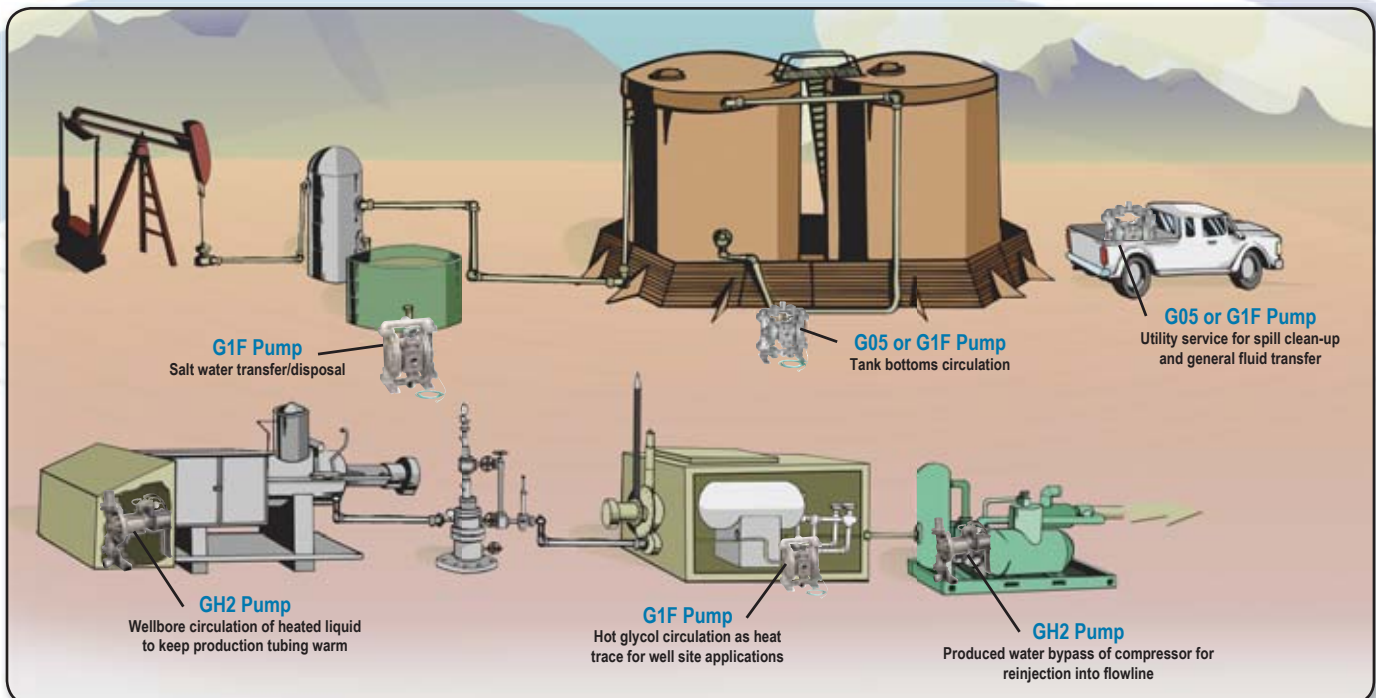

High Pressure Natural Gas Pump



GH2-M
(NACE Standard not applicable)

GH2-M Performance Curve

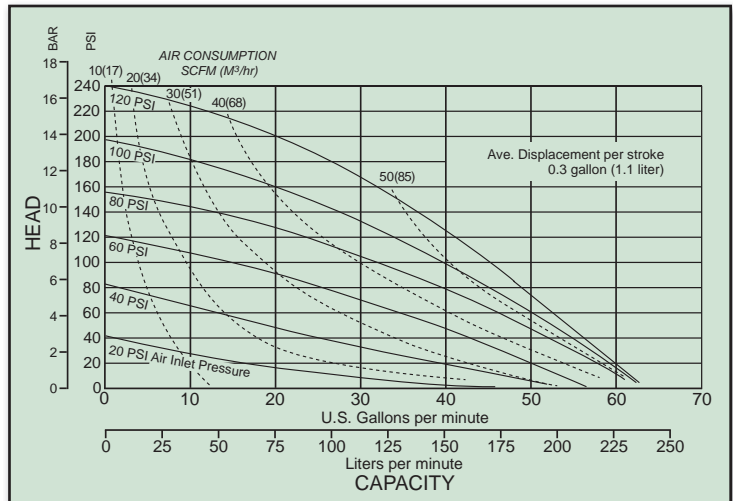

PUMP MODELS	A	B	C	D	E	Connection Style	Pipe Size	Displacement Per Stroke	Max Flow Per Minute	Max Solids Handling	Max Discharge Pressure
	Height	Width	Depth	Bottom of Base to Center Line of:							
	inches (mm)	inches (mm)	inches (mm)	Suction	Discharge						
GH2-M	25 (635)	25 13/16 (656)	11 3/4 (298)	2 3/16 (56)	25 (635)	2" NPT	2 (50)	.30 (1.1)	62 (235)	.25 (6)	250 (17.2)

All Dimensions +/- 1/8 (3)

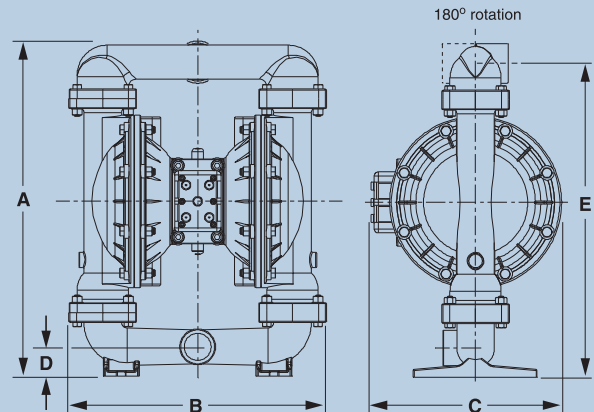
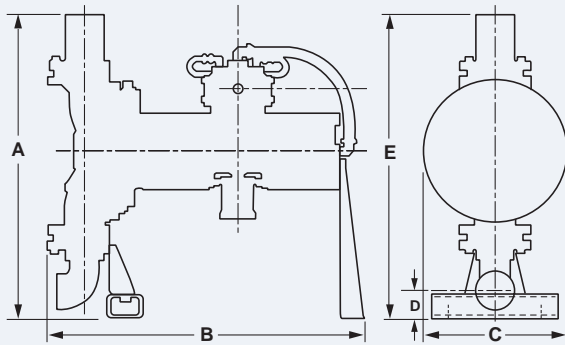

PUMP MODELS	A	B	C	D	E	Connection Style	Pipe Size	Displacement Per Stroke	Max Flow Per Minute	Max Solids Handling	Max Discharge Pressure
	Height	Width	Depth	Bottom of Base to Center Line of:							
	inches (mm)	inches (mm)	inches (mm)	Suction	Discharge						
G05	11 1/2 (292)	10 1/4 (260)	7 1/16 (179)	1 5/16 (33)	11 1/2 (292)	1" MNPT	.5 (13)	.026 (.098)	15 (57)	.125 (3)	125 (8.6)
G1F	12 23/32 (323)	10 1/4 (260)	10 3/8 (264)	1 3/32 (28)	11 27/32 (301)	1" NPT	1 (25)	.11 (.42)	45 (170)	.25 (6)	125 (8.6)
G15	21 37/64 (548)	16 21/32 (423)	12 23/64 (314)	1 29/32 (49)	20 5/16 (516)	1 1/2" NPT	1.5 (40)	.41 (4.55)	106 (401)	.25 (6)	125 (8.6)
G20	26 5/16 (668)	16 7/8 (428)	12 19/32 (320)	1 7/8 (48)	24 5/8 (625)	2" NPT	2 (50)	.42 (1.59)	150 (567)	.25 (6)	125 (8.6)
G30	32 1/16 (814)	19 21/32 (499)	15 3/4 (400)	2 11/32 (60)	29 31/32 (761)	3" NPT	3 (80)	.94 (3.56)	238 (901)	.38 (9.5)	125 (8.6)

All Dimensions +/- 1/8 (3)

SPECIAL DUTY BALL - NATURAL GAS

G05 Performance Curve

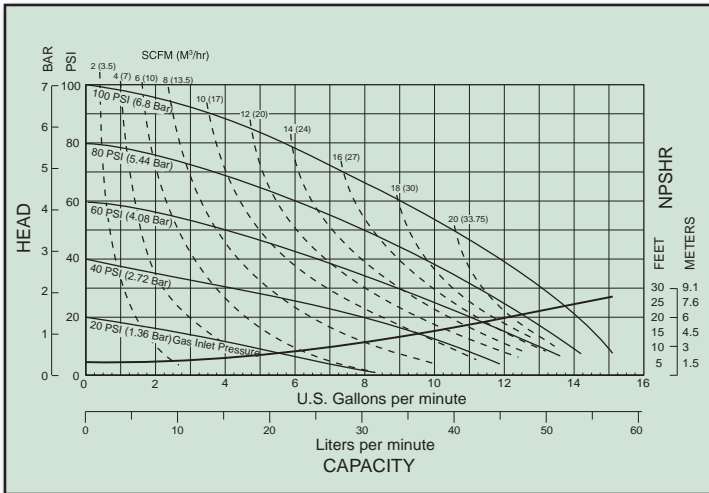

G1F Performance Curve

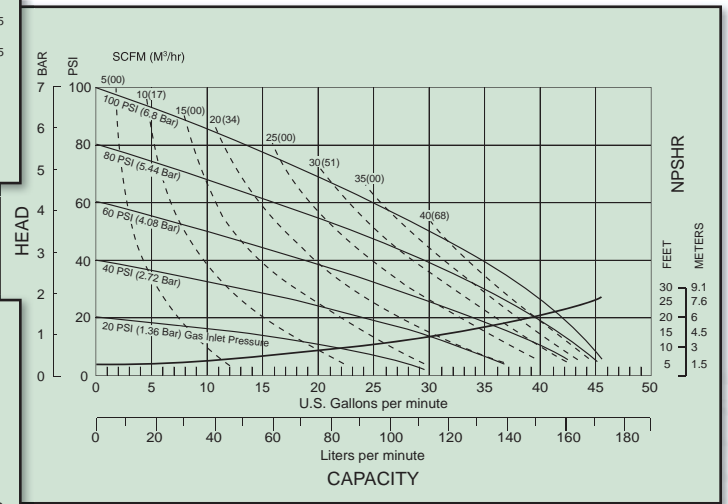

G15 Performance Curve

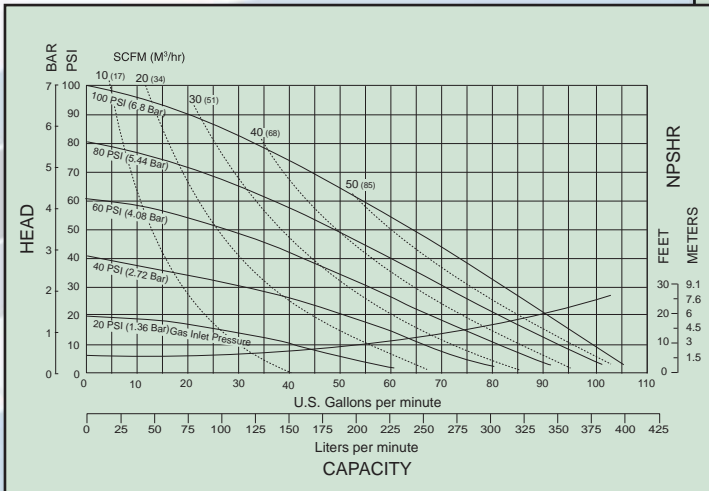

G20 Performance Curve

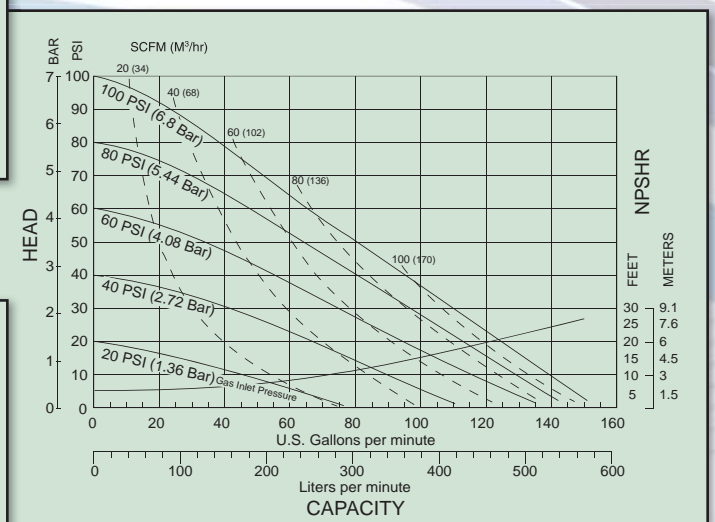

G30 Performance Curve

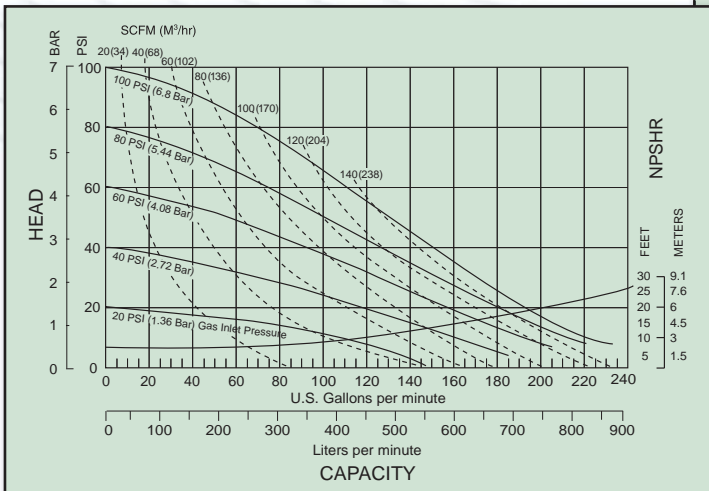

CSA CERTIFIED NATURAL GAS REGULATORS

CSA Certified Natural Gas Regulators

Superior regulation and excellent stability make the 020.057.000 regulator ideal for lower flow applications. Square head adjustment screw allows for easy in-field calibration. The 020.057.000 is available with hand wheel adjustment, output pressure gauge and/or mounting bracket as options.

The 020.058.000 & 020.059.000 contain many of the same characteristics as the 020.060.000, but at a reduced cost. At 110 SCFM (16.5 Mbtu/hr.), the 020.059.000 offers flow rates comparable to current market suppliers. The use of a relief valve is recommended for this product in accordance with NFPA 58.

The 020.060.000 uses a patented balanced pintle design which eliminates unsteady changes in outlet pressure due to inlet pressure fluctuations. The 020.060.000 is a spring opposed, diaphragm-operated, non-relieving regulator. The use of a relief valve is recommended for this product in accordance with NFPA 58.

All of the regulators have vent ports that are tapped 1/4" NPT. A pipe or hose fitting can be installed and any natural gas that escapes due to a diaphragm rupture can be diverted to be reclaimed. No gas is vented into the surrounding atmosphere. This feature provides for a safer regulator and is environmentally friendly.

Note: Regulators come standard with gauge. Replacement gauges 020.061.000 are available.



1/4" Regulator
020.057.000



1/2" Regulator
020.058.000



3/4" Regulator
020.059.000



3/4" Regulator
020.060.000

Interceptor (Particulate Removal) 3P U - Aluminum Housing Filter

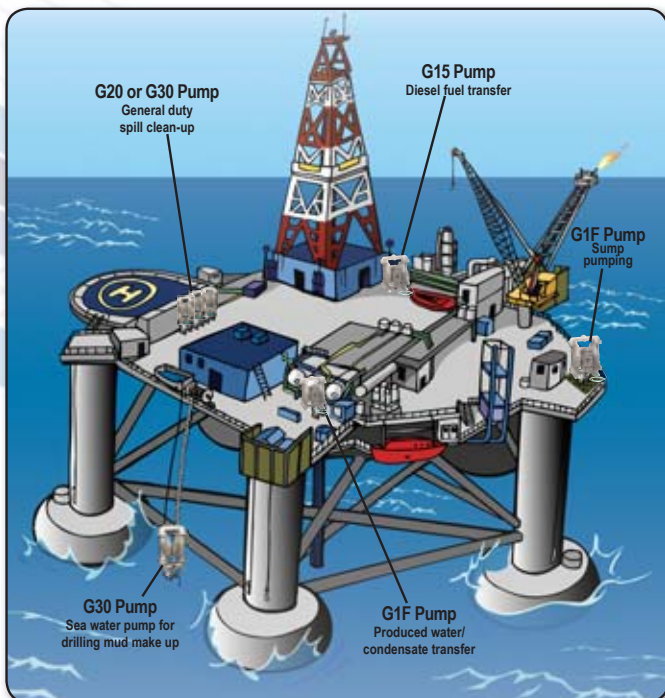

Natural Gas-Operated Pumps used for Offshore Drilling and Production Applications

Applications:

- Particulate removal where very high dirt-holding capacity is required. Safety after filter for desiccant dryer, pore matched prefilter for coalescer or as general use for final instrument air protection.
- Desiccant dryer after filter
- Prefilter for coalescer
- Systems with high concentrations of solid contaminant
- Particulate protection for non-lubricated systems



1/4" NPT Filter: 020.062.000
Replacement Element: 020.065.000

3/4" NPT Filter: 020.064.000
Replacement Element: 020.066.000

Interceptor End Seals: U=Molded urethane.
Standard on all 3P pleated cellulose filter elements.

ONE-PIECE DIAPHRAGM

SANDPIPER One-Piece

PTFE with a Nitrile backer

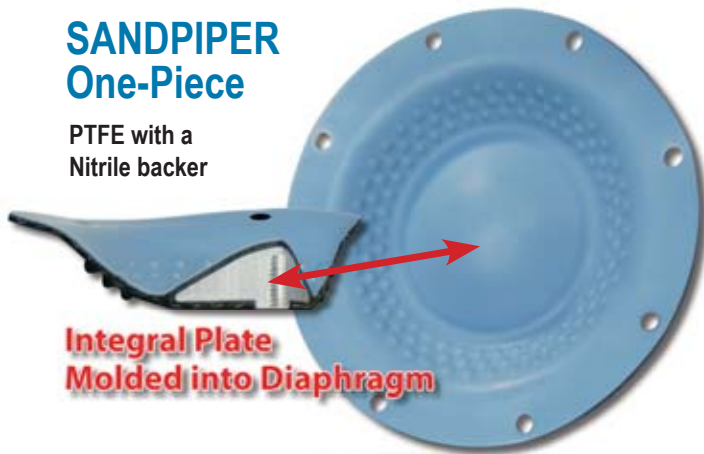

Gore One-Up®

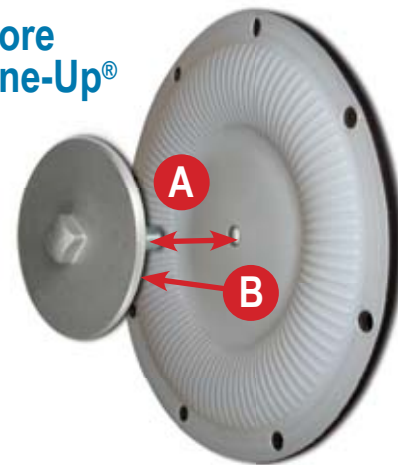

BENEFITS of our One-Piece Diaphragm assembly are:

- TORQUE-FREE – “Spin & Go” – one-piece diaphragm is simply hand turned into position
- Tool-less installation
- Fewer leak paths **A**
- Fewer parts – less inventory
- No outer diaphragm plate abrasion due to trapped fluids **B**
- Diaphragm flex life improvements of 20% to 400% as reported by end users and documented lab testing
- Start-up pressure of less than 10 psi on SANDPIPER One-Piece Diaphragm vs. 25 psi or more on competitive designs

Compare the SAVINGS

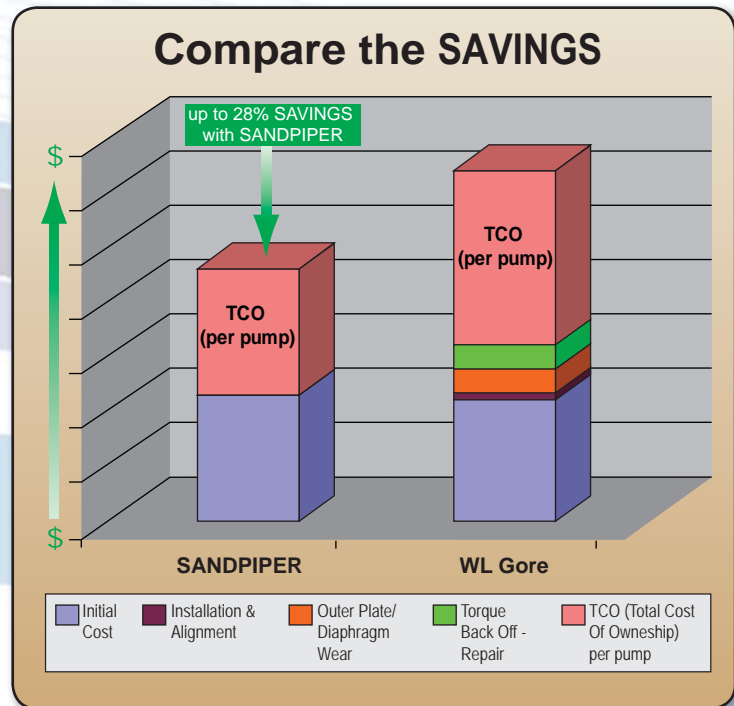

Part Number (Conversion Kit)*	Inner diaphragm Plate**	Where Used	Wet End Kit	Where Used
286.116.000 (475.251.000)	612.221.330	S05, S07, S10 Non-Metallic and S05 Metallic	476.202.659 476.199.659	S05 Non-Metallic S05 Metallic
286.112.000 (475.250.000)	612.218.330	S1F Metallic, SB1	476.034.659 476.194.659	SB1-A S1F Metallic
286.118.000 (475.252.000)	612.215.330	HDB2	476.043.659	HDB2
286.118.000 (475.253.000)	612.214.150	S20 Metallic	476.042.659	S20 Metallic
286.113.000 (475.254.000)	612.217.150	S15 Metallic	476.182.659	S15 Metallic
286.114.000 (475.255.000)	612.219.150	HDB1½	476.194.659	HDB1½

*Conversion Kits include (2) Diaphragms w/Studs and (2) Inner Plates

**Order this Inner Diaphragm Plate when ordering the One-Piece Diaphragm

AODD PRINCIPLE OF OPERATION

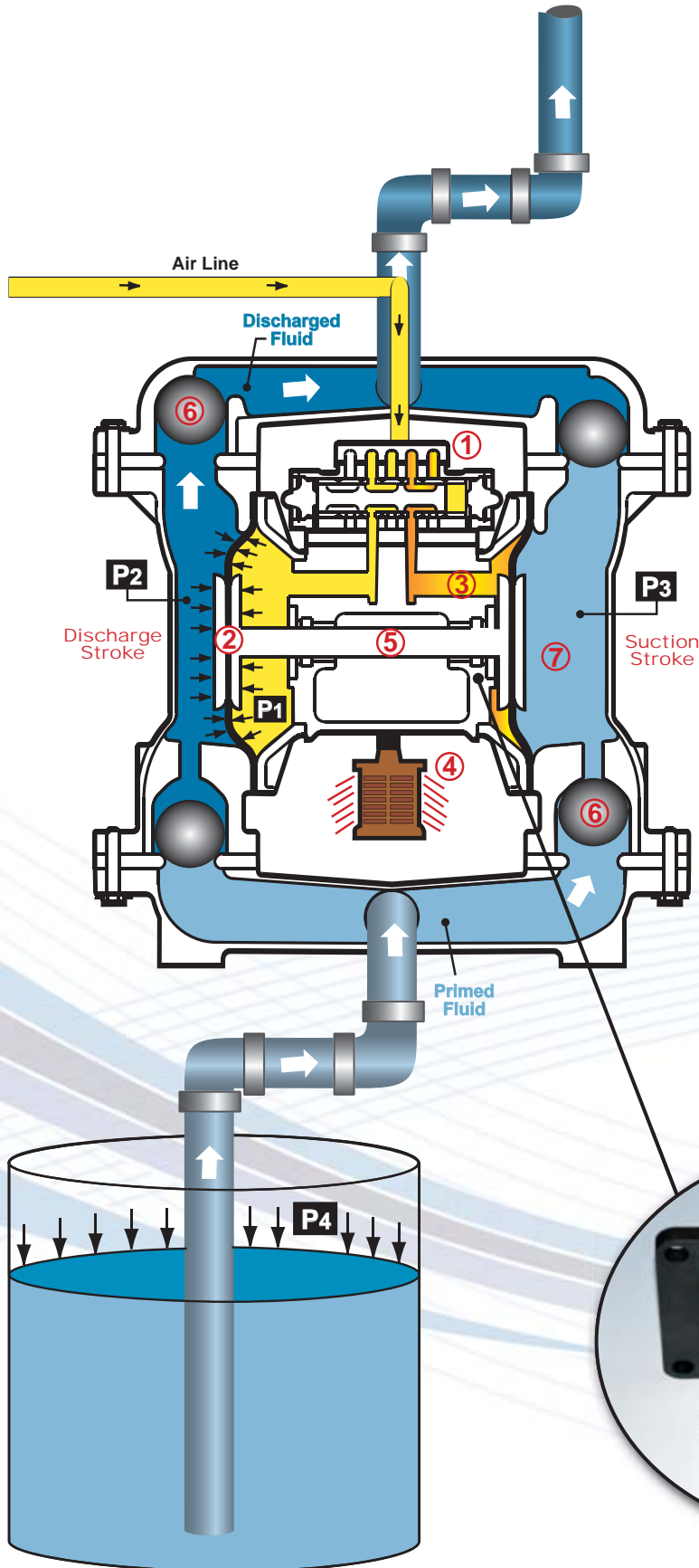

- SANDPIPER® Air-operated double diaphragm (AODD) pumps are powered by compressed air, nitrogen or natural gas.
- The main directional (air) control valve ① distributes compressed air to an air chamber, exerting uniform pressure over the inner surface of the diaphragm ②. At the same time, the exhausting air ③ from behind the opposite diaphragm is directed through the air valve assembly(s) to an exhaust port ④.
- As inner chamber pressure (**P1**) exceeds liquid chamber pressure (**P2**), the rod ⑤ connected diaphragms shift together creating discharge on one side and suction on the opposite side. The discharged and primed liquid's directions are controlled by the check valves (ball or flap) ⑥ orientation.
- The pump primes as a result of the suction stroke. The suction stroke lowers the chamber pressure (**P3**) increasing the chamber volume. This results in a pressure differential necessary for atmospheric pressure (**P4**) to push the fluid through the suction piping and across the suction side check valve and into the outer fluid chamber ⑦.
- Suction (side) stroking also initiates the reciprocating (shifting, stroking or cycling) action of the pump. The suction diaphragm's movement is mechanically pulled through its stroke. The diaphragm's inner plate makes contact with an actuator plunger aligned to shift the pilot signaling valve. Once actuated, the pilot valve sends a pressure signal to the opposite end of the main directional air valve, redirecting the compressed air to the opposite inner chamber.

MATERIALS PROFILE

Material Profile:	Operating Temperatures:	
	Max.	Min.
Conductive Acetal: Tough, impact resistant, ductile. Good abrasion resistance and low friction surface. Generally inert, with good chemical resistance except for strong acids and oxidizing agents.	190°F 88°C	-20°F -29°C
EPDM: Shows very good water and chemical resistance. Has poor resistance to oils and solvents, but is fair in ketones and alcohols.	280°F 138°C	-40°F -40°C
FKM: (Fluorocarbon) Shows good resistance to a wide range of oils and solvents; especially all aliphatic, aromatic and halogenated hydrocarbons, acids, animal and vegetable oils. Hot water or hot aqueous solutions (over 70°F(21°C)) will attack FKM.	350°F 177°C	-40°F -40°C
Hytrel®: Good on acids, bases, amines and glycols at room temperatures only.	220°F 104°C	-20°F -29°C
Neoprene: All purpose. Resistance to vegetable oils. Generally not affected by moderate chemicals, fats, greases and many oils and solvents. Generally attacked by strong oxidizing acids, ketones, esters and nitro hydrocarbons and chlorinated aromatic hydrocarbons.	200°F 93°C	-10°F -23°C
Nitrile: General purpose, oil-resistant. Shows good solvent, oil, water and hydraulic fluid resistance. Should not be used with highly polar solvents like acetone and MEK, ozone, chlorinated hydrocarbons and nitro hydrocarbons.	190°F 88°C	-10°F -23°C
Nylon: 6/6 High strength and toughness over a wide temperature range. Moderate to good resistance to fuels, oils and chemicals.	180°F 82°C	32°F 0°C

Polypropylene: A thermoplastic polymer. Moderate tensile and flex strength. Resists strong acids and alkali. Attacked by chlorine, fuming nitric acid and other strong oxidizing agents.	180°F 82°C	32°F 0°C
PVDF: (Polyvinylidene Fluoride) A durable fluoroplastic with excellent chemical resistance. Excellent for UV applications. High tensile strength and impact resistance.	250°F 121°C	0°F -18°C
Santoprene®: Injection molded thermoplastic elastomer with no fabric layer. Long mechanical flex life. Excellent abrasion resistance.	275°F 135°C	-40°F -40°C
UHMW PE: A thermoplastic that is highly resistant to a broad range of chemicals. Exhibits outstanding abrasion and impact resistance, along with environmental stress-cracking resistance.	180°F 82°C	-35°F -37°C
Urethane: Shows good resistance to abrasives. Has poor resistance to most solvents and oils.	150°F 66°C	32°F 0°C
Virgin PTFE: (PFA/TFE) Chemically inert, virtually impervious. Very few chemicals are known to chemically react with PTFE; molten alkali metals, turbulent liquid or gaseous fluorine and a few fluoro-chemicals such as chlorine trifluoride or oxygen difluoride which readily liberate free fluorine at elevated temperatures.	220°F 104°C	-35°F -37°C

Maximum and Minimum Temperatures are the limits for which these materials can be operated. Temperatures coupled with pressure affect the longevity of diaphragm pump components. Maximum life should not be expected at the extreme limits of the temperature ranges.

Metals:

Alloy C: Equal to ASTM494 CW-12M-1 specification for nickel and nickel alloy.
Stainless Steel: Equal to or exceeding ASTM specification A743 CF-8M for corrosion resistant iron chromium, iron chromium nickel and nickel based alloy castings for general applications. Commonly referred to as 316 Stainless Steel in the pump industry.

For specific applications, always consult the Chemical Resistance Chart.

Recommended Installation Guidelines

For best results, the factory recommends installing the surge suppressor on the discharge side of the pump. Though the more common top-ported pump is shown here, this recommendation also applies to bottom, side and dual-ported diaphragm pumps.

The compressed air supply line to the surge suppressor should connect before a filter/regulator unit limited to inlet air of 125 PSI. To reduce piping and pump connection stresses, we recommend flexible connections on both inlet and outlet piping and air inlet connections.

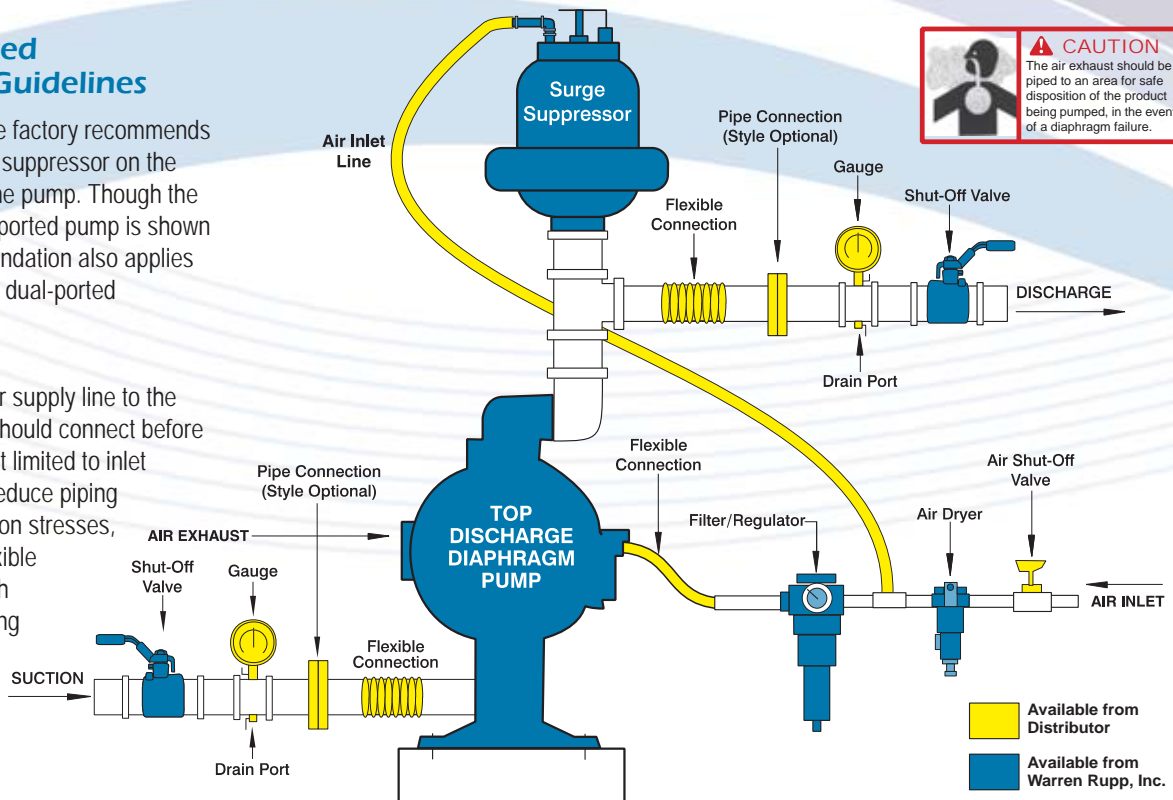

Pump Testing for Quality Assurance

To complete the pump assembly process, ALL PUMPS are tested in the following manner to ensure a quality built SANDPIPER® product:

- Tested at 95 PSI for fluid and air leakage
- Prime from a dry start
- Deadhead the pump (each side) for a specific check for fluid or air leakage (internal and external)
- Observation run cycle at high PSI/cycling rate
 1. Checking for porosity
 2. Rhythmic cycling
 3. Abnormal mechanical noises
 4. Visual inspection
 - Hardware
 - Mating surfaces
 - Pipe threads
 - Wetted materials
- Maximum vacuum check
- Drain and air dry pump

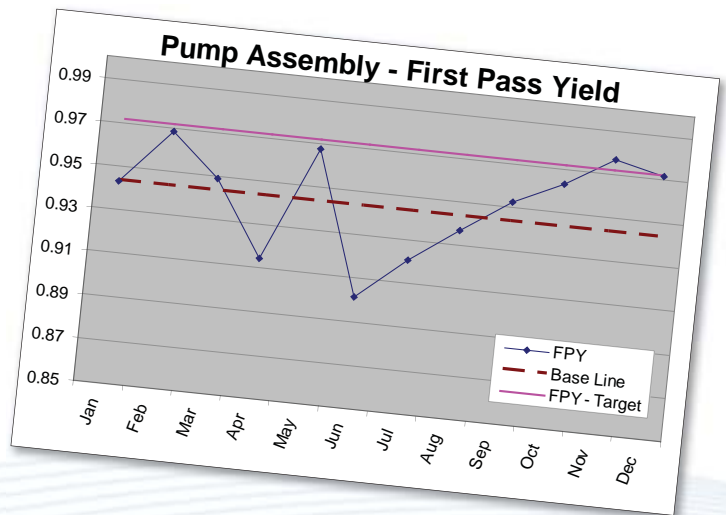

Experienced SANDPIPER assembler monitors pump performance with pressure and vacuum gauges.

5 - YEAR Limited Product Warranty

Quality System ISO9001 Certified
Environmental Management Systems ISO14001 Certified

Warren Rupp, Inc. ("Warren Rupp") warrants to the original end-use purchaser that no product sold by Warren Rupp that bears a Warren Rupp brand shall fail under normal use and service due to a defect in material or workmanship within five years from the date of shipment from Warren Rupp's factory. Warren Rupp brands include SANDPIPER®, MARATHON®, PortaPump®, SludgeMaster™ and Tranquilizer®.

- See complete warranty at www.sandpiperpump.com/About/guaranteesandwarranties.html -

Diaphragm Connecting Rod Guarantee

GUARANTEED - NOT TO YIELD UNDER:
Tension • Compression • Bending • Pump Operation

For complete Guarantee conditions, eligibility requirements and liability, visit us at
www.sandpiperpump.com/About/guaranteesandwarranties.html

Non-Stalling Air Valve Performance Guarantee

If a Warren Rupp ESADS® (Externally Serviceable Air Distribution System) EVER* fails to operate or restart after shutdown due to "centering" of the main air valve or pilot valve, Warren Rupp will replace the air drive system free of charge. Having supplied this UPGRADED, FIELD PROVEN, RETROFITABLE, air drive system since 1996, the absence of any field failures related to design, gives Warren Rupp the CONFIDENCE to offer the ONLY WRITTEN AIR VALVE PERFORMANCE GUARANTEE IN THE AODD INDUSTRY!

- See complete guarantee at www.sandpiperpump.com/About/guaranteesandwarranties.html -

REPAIR IT ONCE, REPAIR IT RIGHT

Use Complete Kits instead of Partial Repairs

- Everything you need in one place
- Reduce frequency of repairs
- Increase service life
- Increase uptime
- Save time and money



**SAVE
\$1,119
ANNUALLY**

COMPLETE KIT VS. PARTIAL REPAIR



COST OF WET END REPAIR	Partial Repair (1 Diaphragm)	Complete Repair Kit
Parts	\$66	\$338
Labor, Down-Time, Lost Product:	\$1,325	\$1,325
Estimated Cost Per Repair:	\$1,391	\$1,663
Annual Frequency of Repair	2	1
Estimated Annual Cost:	\$2,782	\$1,663
Estimated Annual Savings:*	\$0	\$1,119

**Example Data: Repair = 1 hour • Pump model #: S20B1ABBANS000 • Buna wet-end • Repair labor rate fully burdened at \$125/hour • Lost product assumes paint*

SANDPIPER®

GENUINE PARTS

REPAIR KITS

- **SAVE TIME**
- **SAVE MONEY**

**NOW
AVAILABLE**

- **See page 75
for more details**

GENUINE PARTS, REAL VALUE



WITH MORE WAYS THAN ONE... GLOBALLY!

This brochure available in the languages below



ENGLISH



CHINESE



RUSSIAN



PORTUGUESE



SPANISH



GERMAN



JAPANESE

SANDPIPER PUMP

Warren Rupp, Inc. • A Unit of IDEX Corporation

800 North Main Street • P.O. Box 1568 • Mansfield, OH 44901-1568 USA

Phone: (419) 524-8388 • Fax: (419) 522-7867

www.sandpiperpump.com • email: info.warrenrupp@idexcorp.com



SANDPIPER ACCESSORIES
AIR FILTER / REGULATOR
 CROSS REFERENCE GUIDE

Pump Size	Pump Model	Air Line Filter/Regulator Part Number
1/4"	E02, PB1/4	020.103.000
3/8"	WR10	020.103.000
1/2"	S05	020.103.000
	SE1/2	020.104.000
3/4"	S07	020.103.000
1"	S10	020.103.000
	ET1, HDF1, HDF25, N25, S1F, SA1, SA25, SB1, SB25, SET1, ST1, ST25, T1F, U1F	020.104.000
1 1/2"	DSB1, ET1 1/2-SM, SSB1	020.104.000
	ET1 1/2-M, HDB1 1/2, S15, ST1 1/2, ST40, T15	020.105.000
2"	EH2-M, SET2, SH2-M	020.104.000
	ET2, HDB2, HDF2, MSA2, MSB2, N50, S20, SSB2, T20, TSA2, W09-2	020.105.000
	RHDB2, RHDF2, RS20	020.107.000
2 1/2"	SSA2	020.105.000
3"	HDF3, HDF3-A, S30, T30, W09-3	020.105.000
	ET3, HDB3, HDF3-M, MSA3, W15-3	020.106.000
	RS30	020.107.000
4"	HDF4, HDF4-A	020.105.000
	HDB4, HDF4-M, W15-4	020.106.000



SANDPIPER®
 A WARREN RUPP, INC. BRAND

REPAIR IT ONCE, REPAIR IT RIGHT

Use Complete Kits Instead of Partial Repairs

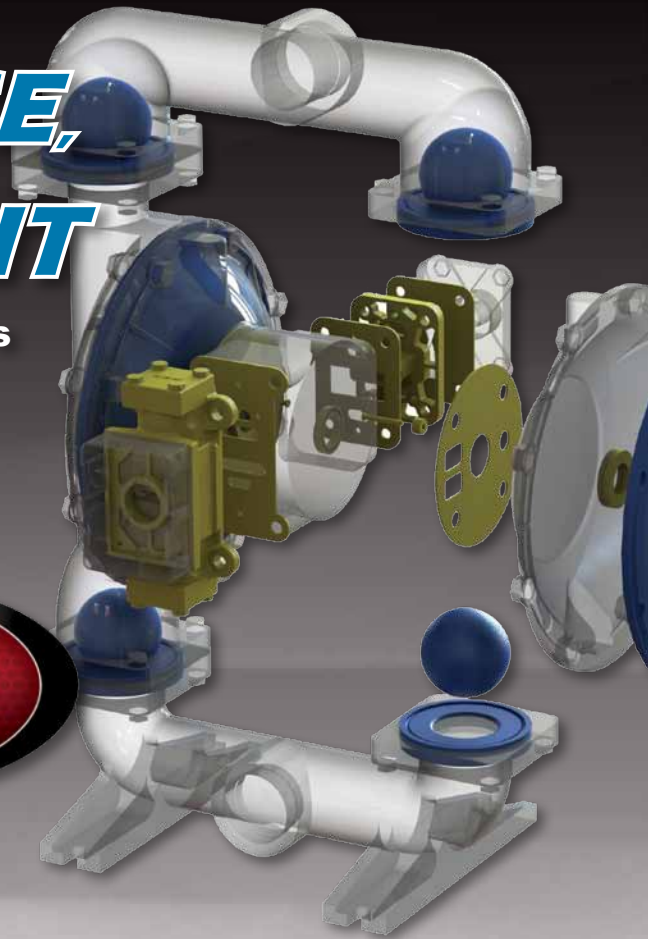

- Everything you need in one place
- Reduce frequency of repairs
- Increase service life
- Increase uptime
- Save time and money

SAVE
\$1,119
ANNUALLY



COMPLETE KIT VS. PARTIAL REPAIR



COST OF WET END REPAIR	 Partial Repair (1 Diaphragm)	 Complete Repair Kit
Parts:	\$66	\$338
Labor, Down-Time, Lost Product:	\$1,325	\$1,325
Estimated Cost per Repair:	\$1,391	\$1,663
Annual Frequency of Repair:	2	1
Estimated Annual Cost:	\$2,782	\$1,663
Estimated Annual Savings*:	\$0	\$1,119

*Example Data: Repair = 1 hour • Pump model #: S20B1ABBANS000 • Buna wet end • Repair labor rate fully burdened at \$125/hour • Lost product assumes paint

SANDPIPER®

GENUINE PARTS



Available in New Kit Packaging:

Series:	Size:	Description:	Item #:
PB 1/4	1/4"	Kit-Wet PB1/4 TF,TF,TF	476.117.600
PB 1/4	1/4"	Kit-Wet PB1/4 SN,SN,TF	476.117.354
S05	1/2"	Kit-Wet S05NM SN,SN,SN	476.202.354
S05	1/2"	Kit-Wet S05NM SN,TF,SN	476.202.654
S07/S10	1/2"	Kit-Wet S07/S10 SN,TF,TF	476.166.654
S05	1/2"	Kit-Wet S05M SN,TF,TF	476.199.654
S05	1/2"	Kit-Wet S05NM PU,PU,TF	476.202.357
S05	1/2"	Kit-Wet S05M BN,BN,PP	476.199.360
S05	1/2"	Kit-Wet S05NM BN,BN,TF	476.202.360
G05	1/2"	Kit-Wet G05 BN,BN,TF	476.238.360
S05	1/2"	Kit-Wet S05M TF,TF,TF	476.199.650
S05	1/2"	Kit-Wet S05NM FKM,TF,TF	476.199.633
S05/S07/S10	1/2" & 3/4"	Kit-Air S05/S07/S10	476.219.000
S07	3/4" T	Kit-Wet S07T BN,BN	476.180.360
S07/S10	3/4"	Kit-Wet S07/S10 SN,SN,TF	476.166.354
S1F	1"	Kit-Wet S1FM BN,BN,UHMW	476.194.360
S1F	1"	Kit-Wet S1FNM SN,SN,TF	476.197.354
SB1	1"	Kit-Wet SB1 NE,TF,TF	476.034.635
S1F	1"	Kit-Wet S1FM TF/NE,TF,TF	476.194.635
S1F	1"	Kit-Wet S1FNM SN,TF,TF	476.197.654
G1F	1"	Kit-Wet G1F BN,BN,TF	476.204.360
S1F	1"	Kit-Wet S1FM SN,SN,UHMW	476.194.354
G1F	1"	Kit-Wet G1F BN,TF,TF	476.204.672
SA1	1"	Kit-Wet SA1 NE,NE,NE	476.033.365
SB1	1"	Kit-Wet SB1 BN,BN,BN	476.034.360
SA1	1"	Kit-Wet SA1 BN,BN,BN	476.033.360
S1F	1"	Kit-Wet S1FM HY,HY,UHMW	476.194.356
SB1	1"	Kit-Wet SB1 NE,NE,NE	476.034.365
SB1	1"	Kit-Wet SB1 SN,SN,SN	476.034.354
HDF1	1"	Kit-Wet HDF1 BN,BN	476.286.360
HDF1	1"	Kit-Wet HDF1 FKM,FKM,FKM	476.286.363
HDF1	1"	Kit-Wet HDF1 NE,NE,NE	476.286.365

Additional kits with new packaging coming soon.
For a complete list of all kits, call 419.524.8388.

Contact Your Distributor Today



Warren Rupp, Inc.,
A Unit of IDEX Corp.
800 N. Main Street
Mansfield, OH 44901 USA
Phone: 419.524.8388
Fax: 419.522.7867
WWW.SANDPIPERPUMP.COM



Distributed By:



YOUR SOLUTION FOR
REPLACEMENT PARTS &
KITS THAT FIT YAMADA®



RIGHT PARTS

MEET OR BEAT YAMADA®
PERFORMANCE & PRICING



RIGHT NOW

FIRST CLASS SERVICE
PARTS WHEN YOU NEED THEM



RIGHT PRICE

PARTS PRICED 20% BELOW
YAMADA® LIST PRICE



RIGHT SOLUTION

47+ YEARS OF EXPERTISE IN
AODD PUMPING TECHNOLOGY



PUMPER PARTS IS A GLOBAL SUPPLIER OF PUMP
REPLACEMENT PARTS, ANSWERING THE DEMAND FOR
QUALITY PRODUCTS AND FAST DELIVERY



PROVIDING THE INDUSTRY'S MOST POPULAR
SERVICE PARTS & KITS

NEW

REPAIR KITS
(AIR END & WET END)

- ✓ **SAVE** time and money
- ✓ **ALL** the parts you need in one place
- ✓ **REDUCE** frequency of repairs
- ✓ **WORLDWIDE** distribution network

REPLACEMENT PARTS

(DIAPHRAGMS, BALLS, SEALS, ETC.)

- ✓ **PERFORMANCE** guaranteed
- ✓ **WARRANTY** identical to Yamada®
- ✓ **FREE** product trials available
- ✓ **GLOBAL** inventory availability

24
Hour
Shipping

NEW

TAG & RELEASE

IDENTIFYING THE RIGHT REPAIR
KIT FOR YOUR SPECIFIC PUMP
MODEL HAS NEVER BEEN EASIER

Visit WWW.PUMPERPARTS.COM for more information about this **FREE** program



ANS/BN/BN
9551-52
9862-99
www.pumperparts.com



Ph: 419.526.7296 • Fax: 419.526.7289 • www.pumperparts.com
Warren Rupp, Inc. • A Unit of IDEX Corp. • 800 N. Main St. • Mansfield, OH 44902 USA
©Copyright 2013 Warren Rupp, Inc. All Rights Reserved.

Pumper Parts and its products are not affiliated with any of the original equipment manufacturers referenced herein. All original equipment manufacturers' names, colors, pictures, descriptions and part numbers are used for identification purposes only. Pumper Parts® is a registered trade name of IDEX Corporation. All other trademarks, registered trademarks and product names are the property of their respective owners. Yamada® is a registered trademark of Yamada Corporation.

IDEX
CORPORATION

PPYAmflyer-rev0113



YOUR SOLUTION FOR
REPLACEMENT PARTS &
KITS THAT FIT ARO®



RIGHT PARTS
MEET OR BEAT ARO®
PERFORMANCE & PRICING



RIGHT NOW
FIRST CLASS SERVICE
PARTS WHEN YOU NEED THEM



RIGHT PRICE
PARTS PRICED 20% BELOW
ARO® LIST PRICE



RIGHT SOLUTION
47+ YEARS OF EXPERTISE IN
AODD PUMPING TECHNOLOGY

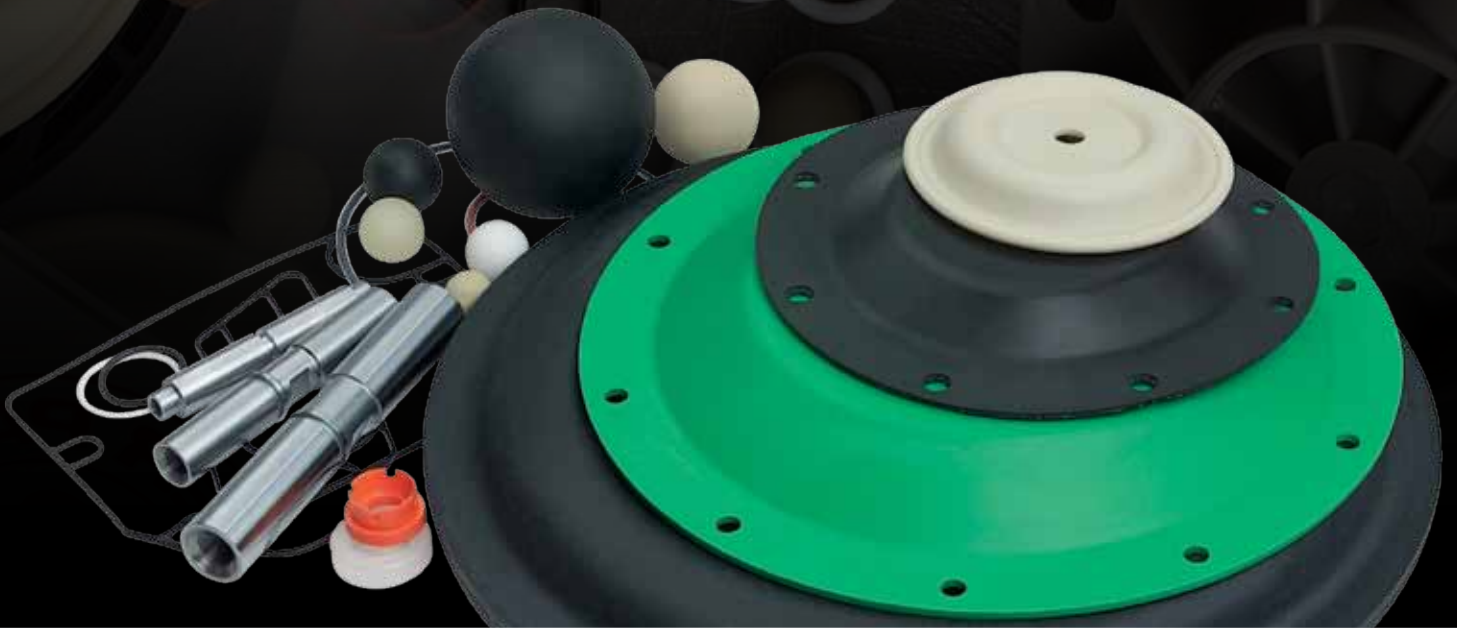

PUMPER PARTS IS A GLOBAL SUPPLIER OF PUMP
REPLACEMENT PARTS, ANSWERING THE DEMAND FOR
QUALITY PRODUCTS AND FAST DELIVERY



PROVIDING THE INDUSTRY'S MOST POPULAR
SERVICE PARTS & KITS

NEW

REPAIR KITS
(AIR END & WET END)

- ✓ **SAVE** time and money
- ✓ **ALL** the parts you need in one place
- ✓ **REDUCE** frequency of repairs
- ✓ **WORLDWIDE** distribution network

REPLACEMENT PARTS

(DIAPHRAGMS, BALLS, SEALS, ETC.)

- ✓ **PERFORMANCE** guaranteed
- ✓ **WARRANTY** identical to ARO®
- ✓ **FREE** product trials available
- ✓ **GLOBAL** inventory availability

24
Hour
Shipping

NEW

TAG & RELEASE

**IDENTIFYING THE RIGHT REPAIR
KIT FOR YOUR SPECIFIC PUMP
MODEL HAS NEVER BEEN EASIER**

Visit WWW.PUMPERPARTS.COM for more information about this **FREE** program



ANS/BN/BN
9551-52
9862-99
www.aro.com for distributor info



Ph: 419.526.7296 • Fax: 419.526.7289 • www.pumperparts.com
Warren Rupp, Inc. • A Unit of IDEX Corp. • 800 N. Main St. • Mansfield, OH 44902 USA
©Copyright 2013 Warren Rupp, Inc. All Rights Reserved.

Pumper Parts and its products are not affiliated with any of the original equipment manufacturers referenced herein. All original equipment manufacturers' names, colors, pictures, descriptions and part numbers are used for identification purposes only. Pumper Parts® is a registered trade name of IDEX Corporation. All other trademarks, registered trademarks and product names are the property of their respective owners. ARO® is a registered trade name of Ingersoll-Rand Company.

IDEX
CORPORATION
PPARoflyer-rev0113



YOUR SOLUTION FOR
REPLACEMENT PARTS &
KITS THAT FIT WILDEN®



RIGHT PARTS

MEET OR BEAT WILDEN®
PERFORMANCE & PRICING



RIGHT NOW

FIRST CLASS SERVICE
PARTS WHEN YOU NEED THEM



RIGHT PRICE

PARTS PRICED 20% BELOW
WILDEN® LIST PRICE



RIGHT SOLUTION

47+ YEARS OF EXPERTISE IN
AODD PUMPING TECHNOLOGY



PUMPER PARTS IS A GLOBAL SUPPLIER OF PUMP
REPLACEMENT PARTS, ANSWERING THE DEMAND FOR
QUALITY PRODUCTS AND FAST DELIVERY



PROVIDING THE INDUSTRY'S MOST POPULAR
SERVICE PARTS & KITS

NEW

REPAIR KITS
(AIR END & WET END)

- ✓ **SAVE** time and money
- ✓ **ALL** the parts you need in one place
- ✓ **REDUCE** frequency of repairs
- ✓ **WORLDWIDE** distribution network

REPLACEMENT PARTS
(DIAPHRAGMS, BALLS, SEALS, ETC.)

- ✓ **PERFORMANCE** guaranteed
- ✓ **WARRANTY** identical to Wilden®
- ✓ **FREE** product trials available
- ✓ **GLOBAL** inventory availability

24
Hour
Shipping

NEW

TAG & RELEASE

**IDENTIFYING THE RIGHT REPAIR
KIT FOR YOUR SPECIFIC PUMP
MODEL HAS NEVER BEEN EASIER**

Visit WWW.PUMPERPARTS.COM for more information about this **FREE** program



ANS/BN/BN
9551-52
9862-99
www.wilden.com



Ph: 419.526.7296 • Fax: 419.526.7289 • www.pumperparts.com
Warren Rupp, Inc. • A Unit of IDEX Corp. • 800 N. Main St. • Mansfield, OH 44902 USA
©Copyright 2013 Warren Rupp, Inc. All Rights Reserved.

Pumper Parts and its products are not affiliated with any of the original equipment manufacturers referenced herein. All original equipment manufacturers' names, colors, pictures, descriptions and part numbers are used for identification purposes only. Pumper Parts® is a registered trade name of IDEX Corporation. All other trademarks, registered trademarks and product names are the property of their respective owners. Wilden® is a registered trade name of Wilden Pump and Engineering Company, a Dover Resources Company.

IDEX
CORPORATION

PPWILDfyer-rev0113

LIQUID LEVEL CONTROL

SANDPIPER
ACCESSORIES



II 2 GD T5



032.036.000

SANDPIPER's float actuated Liquid Level Control unit automatically opens and closes air supply to your pump, bringing the following benefits to your process:



PNEUMATIC

No electrical power required



ADJUSTABLE

Operating range from a few inches to 9 ft (2.7 m)



SIMPLE

Easy to install & operate



VERSATILE

Quick reversible operation



RELIABLE

Stainless Steel float & connecting rod



SAFE

ATEX compliant



UNIVERSAL

Can be used with all AODD pumps

HOW IT WORKS

- 1 Float is raised or lowered
- 2 Float rod activates switch
- 3 Pilot valve is activated
- 4 Regulator turns air on/off to the pump

COMMON APPLICATIONS



Sumping



Dewatering



Fluid Transfer



Tank Filling

REVERSIBLE OPERATION

Operation can be reversed by installing the top float rod bracket in the opposite direction from position shown.

Standard Operation

High Level = On, Low Level = Off

Reverse Operation

High Level = Off, Low Level = On

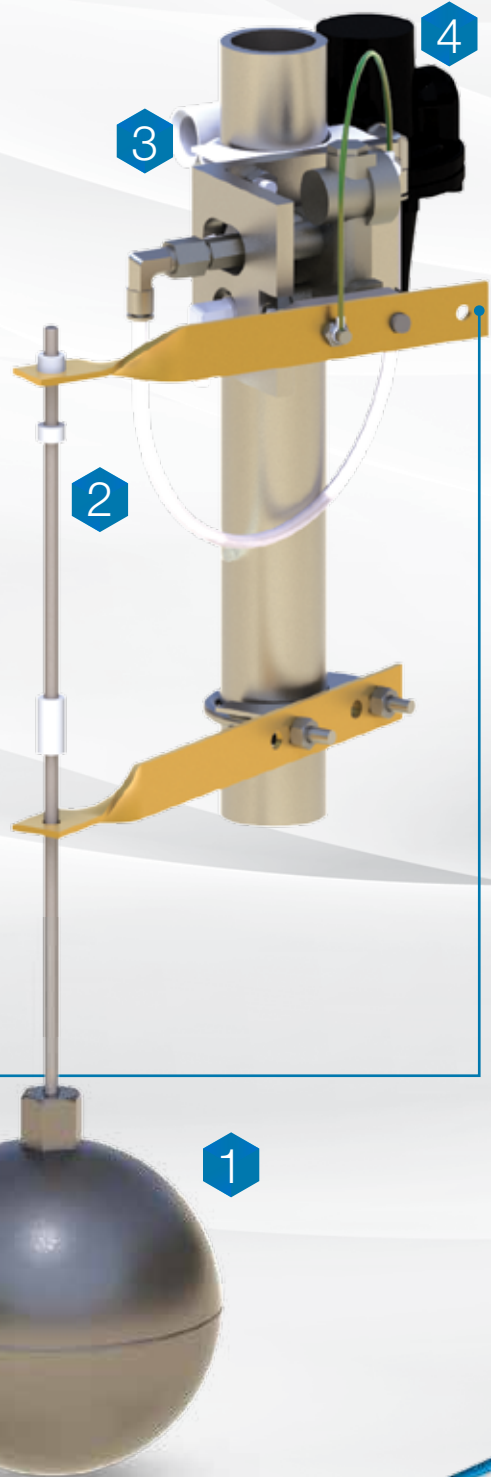

SANDPIPER
ACCESSORIES

Warren Rupp, Inc.
A Unit of IDEX Corporation
800 North Main Street
Mansfield, OH 44902 USA

Phone: 419.524.8388
Fax: 419.522.7867
sandpiperpump.com



IDEX
CORPORATION

Contact Your Local Distributor to Place Your Order:

©Copyright 2013 Warren Rupp, Inc. All Rights Reserved.

sp_LLC_flyer-rev0713