

## Filter/Regulator

**INSTALLATION:** Before installing, blow out pipe line to remove scale and other foreign matter. This unit has DRYSEAL pipe threads. Use pipe compound or tape sparingly to male threads only. Install units in pipeline so that flow is with the arrows as indicated on faces of body. Install as near as possible to equipment serviced.

**MAINTENANCE:** To maintain maximum filtering efficiency and to avoid excessive pressure drop, the filter must be kept clean. Bowl drainage is automatic in the Piston Drain model, however, manual draining can also be done by removing the bowl. A visible coating of dirt or condensate on the filter element surface or an excessive pressure drop is an indication that cleaning is necessary.

**FILTER CLEANING:** To clean, it is not necessary to remove filter from the line. Disassembly is simple and does not require tools. Before disassembly, shut off air supply and depressurize filter. Clean all parts except plastic bowl with alcohol and blow out filter body before reassembly. Wash filter element in alcohol and blow out from the inside. Plastic bowls must be cleaned with household soap only.

**PISTON DRAIN OPERATION:** The Piston Drain mechanism is operated by the pressure drop created as air flow is initiated or as the air line is depressurized. In order to drain properly, there must be sufficient dynamic pressure drop to trigger the drain mechanism. The Piston Drain will not function with minimal flow and pressure variations or on constant flow applications.

**REDUCED PRESSURE ADJUSTMENT:** To adjust reduced pressure setting, loosen lock screw in center of knob and turn knob clockwise to increase pressure setting and counter-clockwise to lower setting. With relieving-type regulators the reduced pressure follows adjustment of the screw.

**REGULATOR CLEANING:** Erratic regulator operation or loss of regulation is generally due to dirt in the disc area. To clean, shut off and depressurize air line and disassemble the regulator. Refer to drawing on reverse as a guide to disassembly and subsequent reassembly. Clean parts with household soap and blow out body with compressed air. When reassembling, make sure the disk assembly is firmly in place and that the disc stem fits into center hole of diaphragm assembly. Tighten cage slightly more than hand tight (to 50 inch/pounds, or 5.65 Newton meters torque).

## Lubricator

**LUBRICANT:** For average conditions, the use of high quality SAE #10 (S.U.V. 150-200 SEC. @ 100°F/38°C) non-detergent oil is recommended.

**FILLING:** Depressurize system and slowly remove the fill plug. Fill to within 1/4"(.635cm) of top of bowl using correct oil. For best results use a long spout oil can. Lubricators may also be filled by depressurizing the system and removing the bowl. After filling, replace the bowl, making sure it has been tightened before repressurizing the system.

**ADJUSTMENT:** The adjustment knob is factory set, fully closed. When turned fully clockwise, no oil is delivered to the venturi for atomization and equipment is not being lubricated. To adjust oil drip rate, turn on the air, start flow and set knob to obtain the desired drip rate. Drip rate is visible through the sight dome. As a start, one or two drop per minute is suggested, correct lubrication being a matter of experience and demand. Clockwise rotation of knob decreases oil feed rate. To check lubrication, hold thumbnail or a mirror near the equipment exhaust. A heavy film indicates over-lubrication and the drip rate should be reduced by turning knob to a lower setting.

**LUBRICATOR MAINTENANCE & CLEANING:** If both air and oil are kept clean and the oil level never allowed below end of tube in the bowl the lubricator should provide long periods of unattended service. When no oil drips through the sight dome, regardless of knob adjustment, cleaning is necessary. To clean, it is not necessary to remove lubricator from the line. Depressurize and disassemble. In most instances cleaning is needed only in the oil metering area. Pull off adjusting knob and unscrew sight dome assembly, remove inner drip spout and clean with household soap. **PLASTIC BOWLS AND SIGHT DOME MUST BE CLEANED WITH HOUSEHOLD SOAP ONLY.**

©Copyright 1997 Warren Rupp, Inc. All rights reserved.

WARREN RUPP, INC. · A Unit of IDEX Corporation · P.O. Box 1568, Mansfield, Ohio 44901-1568 · (419) 524-8388 · Fax (419) 522-7867  
520-189-000 10/97

### ⚠ WARNING ⚠

*The polycarbonate plastic material used to manufacture the plastic bowls and the sight dome on lubricators may be attacked by certain chemicals. DO NOT use these units on systems with air supplied by a compressor lubricated with synthetic oils or oils containing phosphate esters or chlorinated hydrocarbons. These oils carry over into the air lines and will chemically attack or possibly rupture the bowl and lubricator sight dome. DO NOT expose these units to materials such as carbon tetrachloride, trichlorethylene, acetone, paint thinner, cleaning fluids, or other harmful materials. These will cause the plastic to craze and/or rupture. For use in environments where any of these chemicals may be present, consult the factory for approval prior to installation.*

### Filter/Regulator & Lubricator

BOWL	MAX PRESS.	MAX TEMP
PLASTIC	150 psi 10.3 bar	120°F 49°C

### ⚠ WARNING ⚠

*Clean metal bowl and sight glass only with household soap. Do not use denatured alcohol to clean.*

### A Note About Air Valve Lubrication

*The SandPIPER pump's pilot valve and main air valve assemblies are designed to operate WITHOUT lubrication. This is the preferred mode of operation. There may be instances of personal preference, or poor quality air supplies when lubrication of the compressed air supply is required. The pump air system will operate with properly lubricated compressed air supplies. It is important to remember to inspect the sleeve and spool set routinely. It should move back and forth freely. This is most important when the air supply is lubricated. If a lubricator is used, oil accumulation will, over time, collect any debris from the compressed air. This can prevent the pump from operating properly.*

# Filter/Regulator

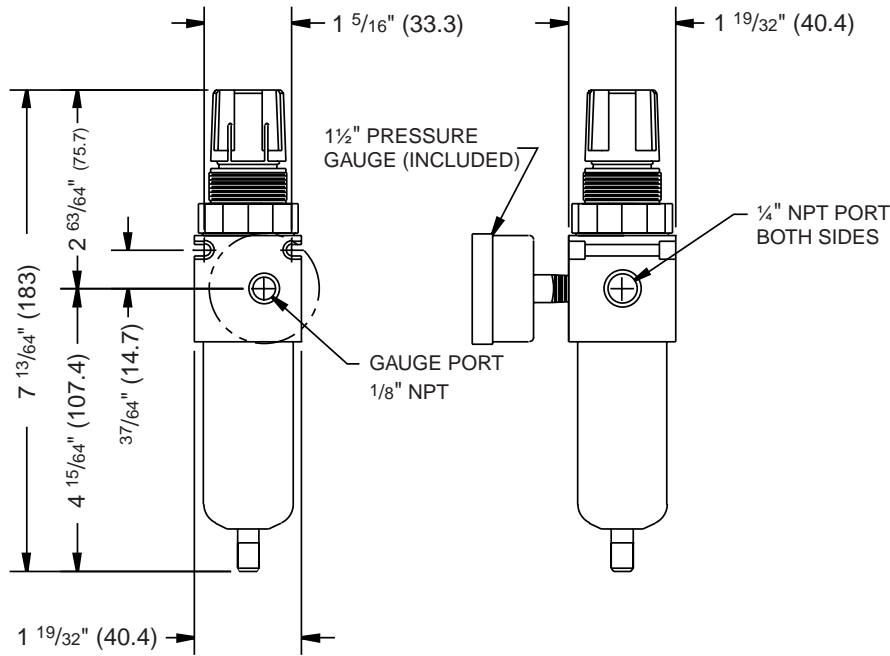

Part No.	Description
020-049-000	1/4" Filter/Regulator <i>Includes Mounting Bracket</i> <i>Air requirements to</i> <i>40 SCFM, 18.7 l/sec.</i>
020-049-001	Lubricator <i>Optional</i>
020-049-002	Shut Off Valve
020-049-004	Replacement Filter for F/R 020-049-000 <i>Includes 20 micron element</i>
020-049-005	Regulator Repair Kit for Regulator 020-049-000 <i>Includes Piston Assembly,</i> <i>Stem &amp; Disc Assembly</i>
020-049-006	Lubricator Repair Kit for Lubricator 020-049-001 <i>Includes Sight Dome</i> <i>Sight Dome Retainer</i> <i>Sight Dome O-Ring</i> <i>Drip Spout</i> <i>Drip Spout O-Ring</i>
020-049-007	Mounting Bracket for F/R 020-049-000
020-049-008	End Plate Kit for F/R 020-049-000, Lubricator 020-049-001, Shut Off Valve 020-049-002
020-053-000	Pressure Gauge for F/R 020-049-000

# Lubricator

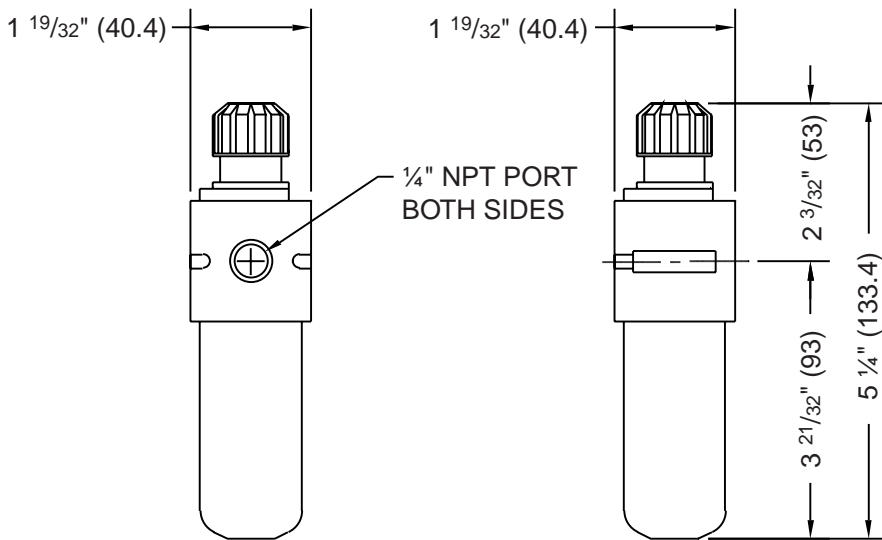

## ⚠ WARNING ⚠

**Clean metal bowl and sight glass only with household soap. Do not use denatured alcohol to clean.**

+-.1/8" (3.2)  
inches (millimeters)